



**A Firefighter's  
Guide To**

**NOZZLES**

***Task Force Tips, Inc. - 800-348-2686***

## **10 COMMON QUESTIONS ABOUT AUTOMATIC NOZZLES**

- 1) *How is an automatic nozzle different from a regular (conventional) nozzle?*
- 2) *How does an automatic nozzle work?*
- 3) *What pressure do we pump to automatic nozzles?*
- 4) *How do I know how much water I am flowing?*
- 5) *What is the flow from each “Click Stop” on the nozzle?*
- 6) *Can I use automatics with foam and foam eductors?*
- 7) *Why don’t all automatic nozzles have spinning teeth?*
- 8) *What type of nozzle is best for “Nozzleman Flow Control?”*
- 9) *Is it true that the stream from a “SOLID” bore nozzle hits harder and goes farther than the “Hollow” stream from a fog nozzle?*
- 10) *What’s all this talk about low pressure nozzles? What are the trade offs, is the compromise worth it?*

Upon completion of this training booklet, you will be able to answer these, and many other, questions pertaining to firefighting nozzles.

The ten questions and complete answers are listed in the appendix.

# CONTENTS

EVOLUTION OF FIRE STREAMS.....	2
EVOLUTION OF COMBINATION NOZZLES .....	3
UNDERSTANDING FIRE NOZZLE DESIGN.....	5
LIMITATIONS OF CONVENTIONAL NOZZLES .....	6
AUTOMATIC NOZZLES INVENTED .....	10
BENEFITS OF AUTOMATIC NOZZLES .....	13
SLIDE VALVE vs. BALL VALVE .....	16
TRAINING CONSIDERATIONS WITH AUTOMATICS .....	18
USING LARGER SIZE ATTACK LINES.....	21
BOOSTER TANK OPERATIONS.....	22
SHAPING THE FIRE STREAM PATTERN.....	23
SMOOTH BORE vs. FOG TIP .....	24
FLUSHING DEBRIS.....	28
NOZZLE REACTION .....	29
DUAL-FORCE/MID-FORCE .....	34
AUTOMATIC NOZZLES & FOAM.....	37
MASTER STREAM AUTOMATICS .....	40
THE WATER TRIANGLE CONCEPT .....	42
CONCLUSION .....	44
LITERATURE 24/7 – Email or Fax .....	45
APPENDIX .....	46
FRICTION LOSS COEFFICIENTS.....	58
FLOW AND REACTION CHARTS .....	61

# **EVOLUTION OF FIRE STREAMS**

## **17th Century (Bucket Brigades)**

Leather buckets were passed from person to person forming a line from the supply source to volunteers positioned near the fire. The water was applied, by the volunteers, in the best way they could.

## **18th Century (Hose Companies)**

Leather hose and copper/brass playpipes.

Sewn leather hose gave way to copper riveted hose.

## **19th Century (Engine & Hose Companies)**

2.5" Cotton Hose & Underwriters Pipe (1888).

## **20th Century**

40's & 50's: 1.5" hose and assorted water spray nozzles.

50's & 60's: 1.5" hose combination, fixed and adjustable gallonage nozzles.

60's & 70's: 1.5" & 1.75" hose, automatic nozzle introduced by C.H. McMillan.

70's & 80's: 1.75" & 2.0" hose, wide spread acceptance of automatic nozzles.

80's & 90's: Light weight 1.75" & 2.0" hose and introduction of dual pressure nozzles and special application attachments.

## **21<sup>st</sup> Century**

Lightweight 2.5" & 3.0" hose and introduction of safe, offensive portable monitor.

# EVOLUTION OF THE COMBINATION NOZZLE (FOG NOZZLE)

The combination nozzle used today in the North American fire service is a simple variation of the straight stream nozzle of the late nineteenth and early twentieth centuries. A standard smooth bore nozzle gives little in the way of stream choices. One diameter, one flow... @ 50 psi.

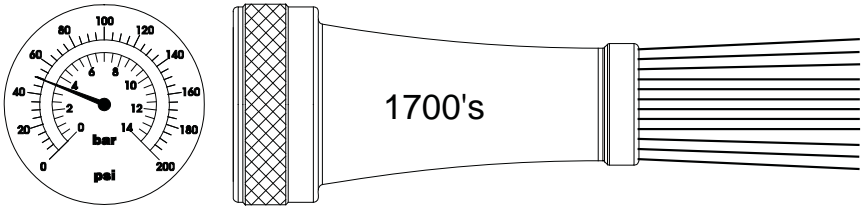

To change streams required changing nozzle size.

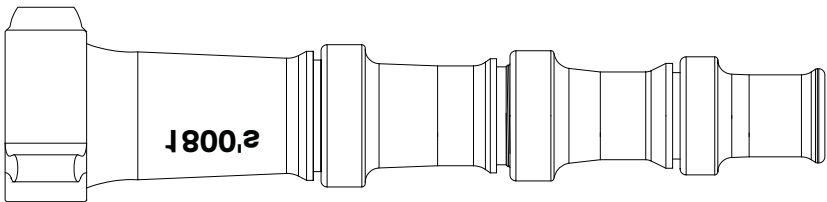

All sizes of tip for use with this nozzle  
allow for quick and easy change

The Addition of a Baffle (disc) added two features:

## 1) Flow Adjustment

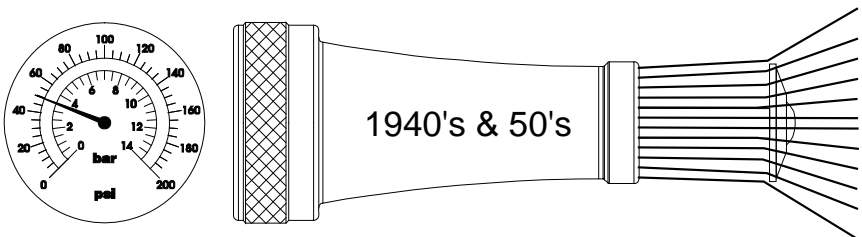

The Baffle space changes for different gallonage.

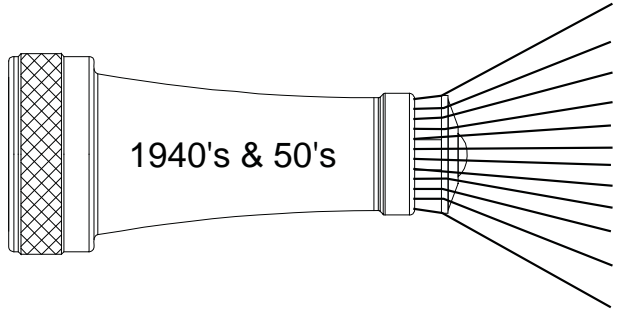
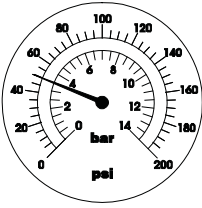

Flow is determined by how far the baffle (disc) is from the circular opening. The distance is preset in fixed gallonage combination nozzles and is changeable in adjustable gallonage nozzles.

2) Pattern Adjustment

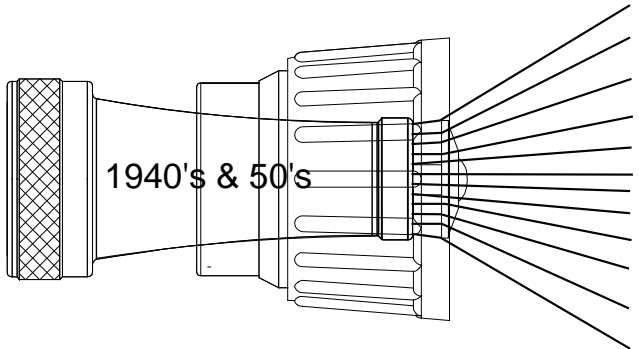
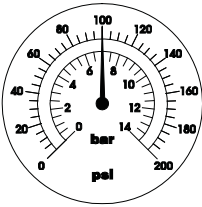

Moving the shaper back widens the pattern.

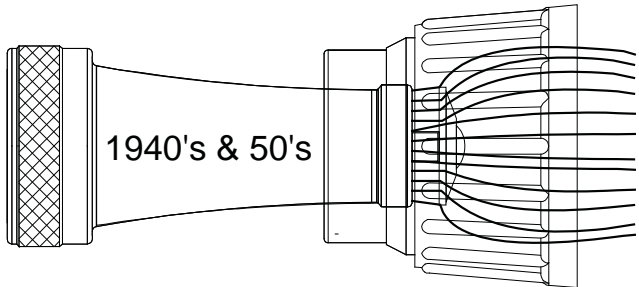
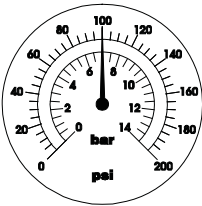

Moving the shaper forward focuses the water and a tight solid stream can be achieved.

# UNDERSTANDING FIRE NOZZLE DESIGN

The purpose of any nozzle is to provide a restriction of the flow to build pressure. This restriction, and subsequent created pressure, provides a usable velocity to project the water stream. For any one flow, there is one correct nozzle size (restriction) to develop the optimum pressure and velocity. Nozzles come in a confusing number of sizes, shapes and styles. The large number of combinations greatly increases the possibility of hydraulics problems being encountered on the fireground.

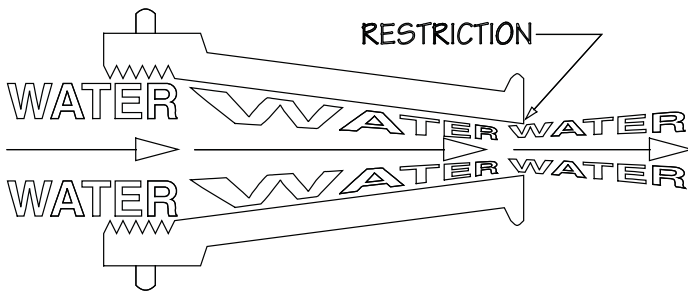

*Fig. 7*

## SMOOTH BORES:

Fixed opening sized from 1/2" to 1-1/4" for handline firefighting operations

Larger stream (GPM) sized from 1-1/4" to 2"

For each flow, there is ONE CORRECT nozzle size to develop optimum velocity and reach

## FOG NOZZLES:

Fixed or very limited gallonage selections

Require adjustments that limit nozzle performance

Require correct pump discharge pressure for best performance and GPM delivery

## DESIGNED NOZZLE PRESSURES

Smooth Bore Nozzle - Handline - 50 PSI

Smooth Bore Nozzle - Master Stream - 80 PSI

Fog Nozzle (all types) - 100 PSI

Current conventional nozzles (“conventional” refers to a nozzle with a fixed size opening or manually adjustable opening) come in two basic types: 1. smooth bore and 2. peripheral jet, more commonly known as fog nozzles (Fig. 8). To allow for changing water conditions and to add greater flexibility (and often confusion), smooth bore nozzles are also available with stacked tips of increasing size.

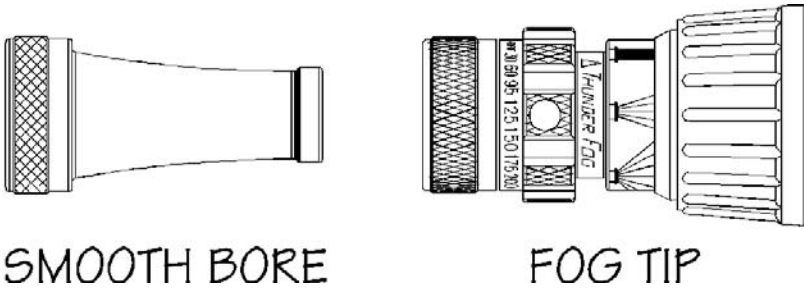

*Fig. 8*

Many fog nozzles, booster through master stream, operate similar to a stacked tip by use of a gallonage ring that manually adjusts the discharge opening (restriction) of the nozzle. Though manually adjusted tips improve the situation over fixed sizes (smooth bores), maximum efficiency is not achieved. Complete coordination between the pump operator, supplying the correct pump discharge pressure, and the nozzle operator is normally impossible. Will the pump operator pump to a predetermined setting? If so, is the nozzle actually set to that position? Has the nozzle operator made a change in the setting, assuming that it will change the flow delivered? The problems multiply!

## **LIMITATIONS OF CONVENTIONAL NOZZLES**

In order for a conventional nozzle with a fixed opening (either smooth bore or fog) to operate at the



correct nozzle pressure, the proper flow (GPM), determined by the correct pump discharge pressure, must be supplied (Fig. 9).



**Fig. 9**

These flow requirements must include consideration of the available water supply, hose size and length, and the pumping capability of the supplying engine. **IF** all things go right, a given flow of water passes through the nozzle to produce the desired nozzle pressure and stream. A big **IF!!!**

If the proper fire stream is attained, the flow to that nozzle cannot be altered unless the discharge opening is changed (manually adjusted) for the new flow, with a corresponding adjustment in pump discharge pressure. Since conventional nozzles cannot change size, or are very limited in adjustment, one of two things must happen.

When a conventional nozzle is supplied less than the rated flow, the result is a weak, less effective, stream. This situation may be due to poor water supply, long hose lays, improper selection of tip size, or pump operator error (Fig. 10). This under-pressured stream may waste water, because the velocity needed to reach the seat of the fire is not produced. This under pressure stream may cause the hose to kink more easily, therefore, reducing the flow even more! It may jeopardize the safety of the nozzle crew. Little, if any, knockdown capability is achieved. Poor water supplies are often blamed for poor fire streams. *More often, poor streams result from the inability to match the correct nozzle size to the water supply that is available!*



Fig. 10

On the other hand, if more than the required flow is being delivered to the conventional nozzle, excessive nozzle pressure will result (Fig. 11). This excessive flow will produce a proportionally higher nozzle pressure and, therefore, a corresponding increase in reaction, or “kickback”.

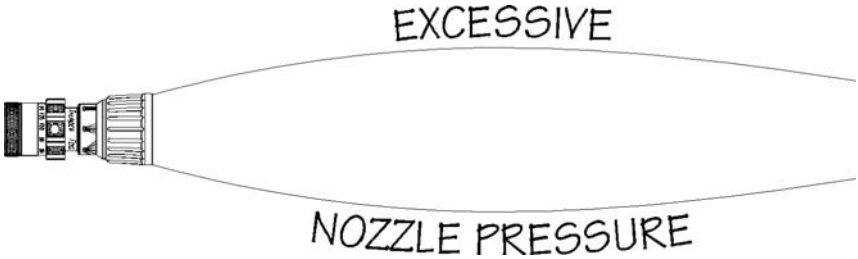
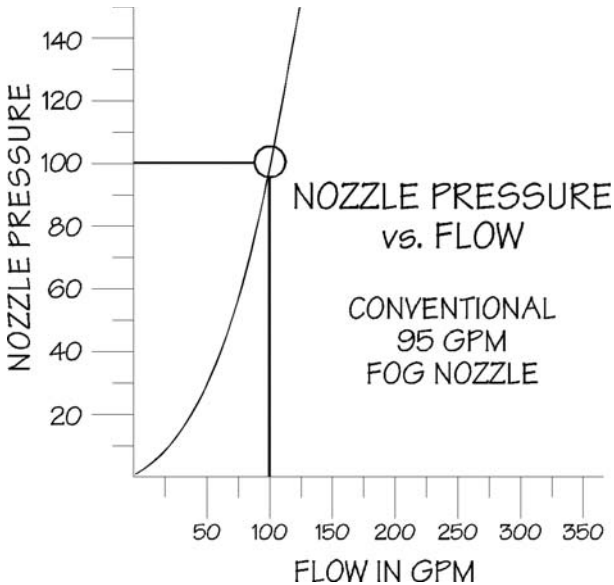

Fig. 11

The higher nozzle reaction will make the hose line more difficult to handle. It may jeopardize the safety of the nozzle crew in an environment that is already unsafe. This dramatic difference in nozzle pressure can be shown graphically (Chart A).



*Chart A*

Any attempt to control the over-pressured line, by the nozzle operator cutting back at the nozzle, results in a fire stream that is broken and erratic. A partially open ball valve creates tremendous turbulence which reduces the stream's effectiveness. The nozzle crew must make a decision; fight the hose line and the fire, or fight the fire with a broken, ineffective, stream.

It becomes obvious when a handline is over pressurized. What about a master stream device that is being operated at a pressure higher than normal? We can't "feel" the reaction or kickback. The high flow rate of a master stream device, added to the higher than normal pressure, may create a dangerously high nozzle reaction. This may add unnecessary stress to aerial ladders or elevated platforms.

In addition, the potential extra water available, evidenced by the high nozzle pressure, is not delivered effectively. A larger size nozzle for the extra water is required (changing the tip size).

The high flow, if delivered through the correct size opening, results in a reduction in nozzle reaction and also the required engine pressure.

What if there was a nozzle invented that would “automatically” size itself to the correct nozzle size for the GPM being delivered to it?

## **AUTOMATIC NOZZLES INVENTED**

The automatic nozzle, also referred to as a pressure-regulating or a constant pressure nozzle, was developed in the late 1960's by Chief C.H. McMillan of the Gary, Indiana, Fire Task Force and founder of TASK FORCE TIPS, Inc. The nozzle was developed to solve the problems of using big streams with limited water supplies. A benefit of the automatic nozzle has been the many improvements of all aspects of firefighting involving water. This has resulted in new improved tactics, greater attack effectiveness, and greater flow deliveries than ever before possible.

For example, let's do a comparison that may make the automatic nozzle seem less mysterious.

A fixed gallonage or smooth bore nozzle is similar to using a manual transmission. As the vehicle speed (flow) increases or decreases, the correct gear (nozzle opening) must be selected and manually changed for proper stream quality.

The automatic nozzle is similar to an automatic transmission. As the vehicle speed (flow) increases or decreases, the correct gear (nozzle opening) is automatically selected, producing proper stream quality all the time.

With current technology, the automatic transmission (the automatic pressure regulating nozzle) is now the method of choice. It is the simplest (from the operator's perspective), requires the least amount of specialized training, and is most efficient at changing to the best gear at the proper time. For whatever "speed" (flow) you choose, the automatic will adjust to give you the proper "gear" (flow opening).

The automatic nozzle uses a principle very similar to that of a pumper relief valve. The pressure control mechanism senses the pressure at the base of the nozzle (Fig. 12). Slight adjustments are made automatically to maintain the optimum nozzle pressure for the flow that is being delivered.

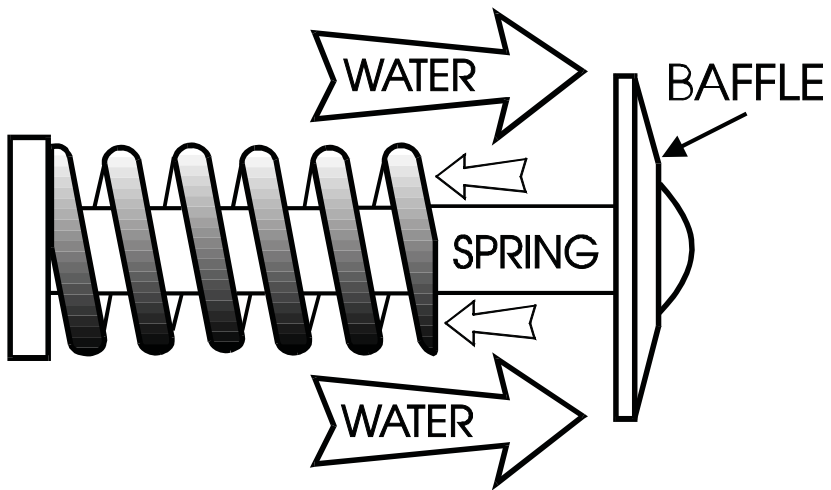

*Fig. 12*

The primary baffle, attached to the pressure control unit, varies the discharge opening of the nozzle (Fig. 13). In effect, the nozzle is constantly changing "tip size" to match the water being delivered. This allows the flow being supplied to be delivered at the proper nozzle pressure and correct velocity.

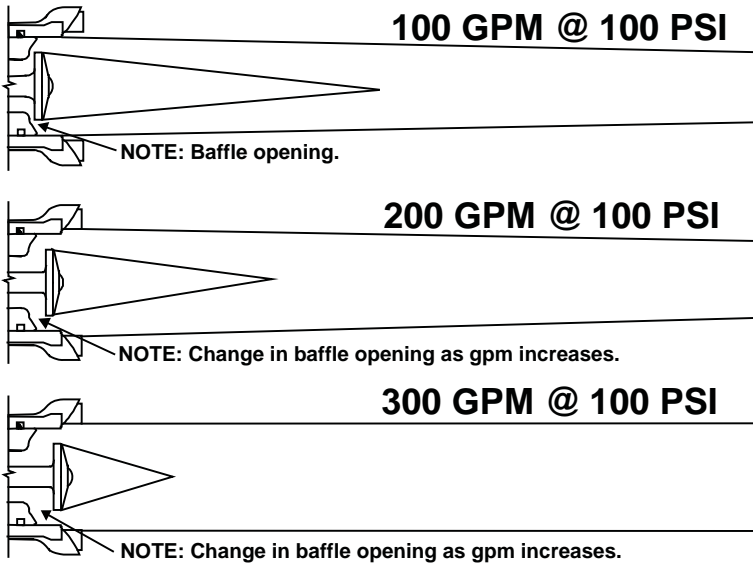

*Fig. 13*

This variable gallon-per-minute rating allows one automatic nozzle to take the place of many conventional nozzles. An H-VPGI, TFT Handline, automatic nozzle with a flow range of 50-350 GPM, or a TFT Dual-Force with a flow range of 70-250 GPM, can be used on **any size hose from 1-1/2" to 3"**. This wide flow range would require many different conventional nozzle sizes!

The pressure-regulating principle used in the TFT Handline automatic nozzle is also used in the Ultimatic 125 Booster (10-125 GPM), the Mid-Matic (70-200 GPM) the Master Stream (150-1250 GPM), the Monsoon (300-2000 GPM) and the Typhoon (600-4000 GPM). The wide flow range of the Master Stream nozzle allows one nozzle to be used, rather than a wide assortment of conventional fog or smooth bore tips.

Unlike the conventional nozzles, the automatic allows for proper nozzle pressure under a variety of changing flow conditions.

# **BENEFITS OF AUTOMATIC NOZZLES**

- Consistent hard-hitting streams
- Correct nozzle pressure with available flow (GPM)
- Maximum reach with available water
- Capable of higher “initial attack” flows
- “Nozzleman Flow Control” with patented slide valve

## **Consistent Hard-Hitting Streams**

To obtain the proper “punch” that is necessary for an aggressive attack, an automatic maintains the optimum nozzle pressure at all times. The fire stream pressure is unaffected by upstream variables that may be unknown to the pump operator or hose crew.

## **Proper Nozzle Pressure With Available Flow**

With changing water supply, the automatic will adjust to the flow available and use the water most effectively. If the flow to the nozzle is increased, the automatic will increase the opening size to accommodate the larger flow. In situations where water supply is not adequate, or when sufficient lines have not been established to move the water available, the automatic will adjust to make best use of the supply until the system can be improved. If the water supply to the nozzle is reduced, the same nozzle pressure will continue to be maintained by decreasing the baffle opening size.

## **Maximum Reach With Available Water**

To gain the greatest reach with a fire stream, maximum flow must be delivered at the correct velocity. By maintaining nozzle pressure (and velocity), the automatic nozzle will always produce the maximum reach possible with the available water supply.

## Higher Initial Attack Flow Rates

If the water is available, we normally attempt to deliver the rated capacity of the nozzle. More water can only be supplied to the conventional nozzle at the risk of a higher nozzle pressure and reaction. Excessive engine pressures would also be necessary to compensate for the increased friction loss and the higher than normal nozzle pressure.

With an automatic nozzle, an increase in pump discharge pressure is all that is necessary to move a higher flow. The nozzle pressure remains constant; and the extra engine pressure is dissipated, as additional friction loss, producing a higher flow.

The difference between engine pressure and nozzle pressure (with the valve fully opened) is the friction loss produced in moving the volume of water through a length of hose. The basic formula for pump discharge pressure,  $PDP = NP + TPL$  (total pressure loss = appliance friction loss + hoseline friction loss + elevation pressure), still applies. With an automatic, the nozzle pressure remains constant and the formula can be rewritten as  $PDP = 100 + TPL$ .

For example (Fig. 14a), a 150 foot 1-1/2" automatic preconnect can move 170 GPM at 200 PSI engine pressure.

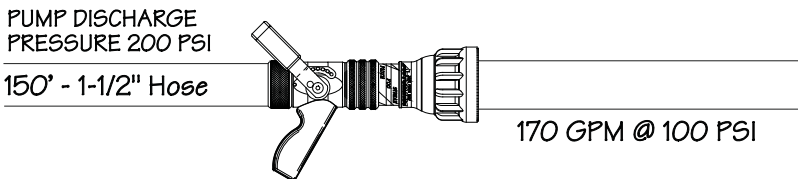

**Fig. 14a**

This is a 50% to 70% increase in flow when compared to a conventional nozzle. When used with the same length of 1-3/4" hose, automatics can easily flow 200 GPM for initial attack (Fig. 14b). A higher flow rate from the first line on the fire can make the difference between success and failure.



PUMP DISCHARGE  
PRESSURE 200 PSI

150' - 1-3/4" Hose

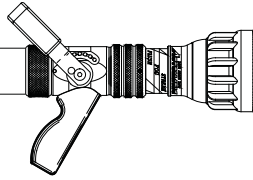

200 GPM @ 100 PSI

*Fig. 14b*

### Nozzleman Flow Control

Higher flow rates and pressure regulation are not the total answer and may present specific problems. Even with pressure regulation, higher flow rates will produce higher nozzle reactions and, consequently, require better control of the flow by the hose crew. It may result in a greater waste of water, possibly causing greater water damage, if proper care is not used. The total answer? The automatic nozzle **MUST** have “Nozzleman Flow Control”.

The automatic pressure control mechanism and patented slide valve within the nozzle allow the flow to be regulated, up to the maximum that is supplied by the hose layout, without affecting the nozzle pressure or stream quality. The use of the shutoff as a throttle also simplifies operation. This gives the nozzle crew control that is not otherwise available.

“Nozzleman Flow Control” with an exclusive turbulence-free slide valve, allows a nozzle operator to easily adjust the flow to what is needed or what can safely be handled. This has an effect of not only reducing fatigue and increasing safety, but it instills greater confidence in the attack team. They know they have the higher flow rate, if needed; and a much more confident, aggressive attack can be made.

Individual nozzle crews can adjust their flow to what they need. Water use is kept to a minimum, and water damage can be reduced (Fig. 15).

## TFT Slide Valve

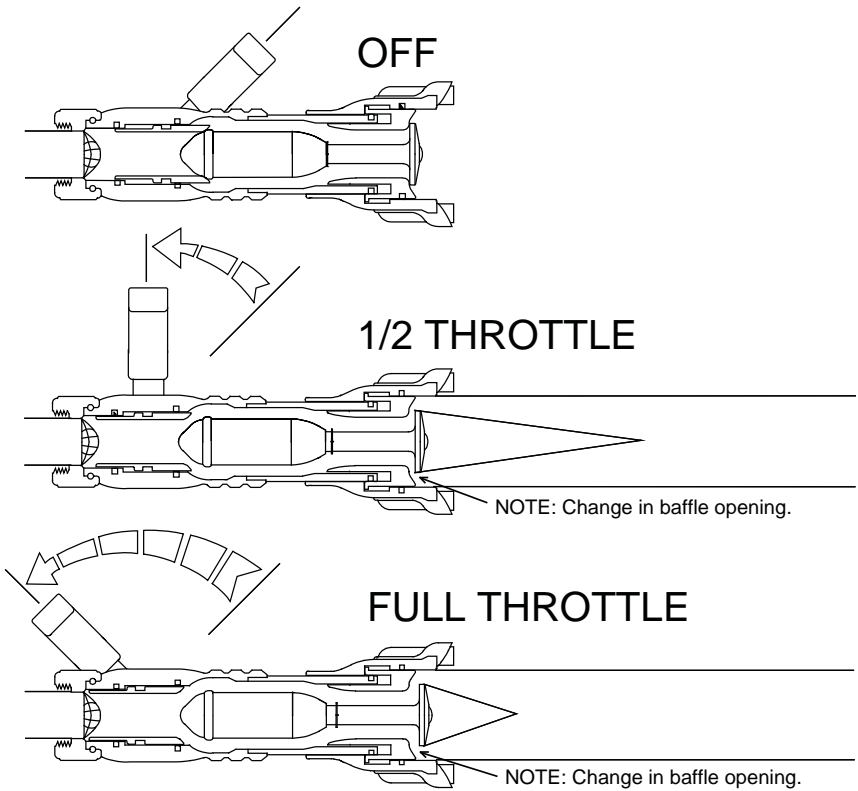

*Fig. 15*

## **Slide Valve vs. Ball Valve**

### Slide Valve

This innovative slide valve has been proven in the Handline, Mid-Matic and Ultimatic styles. **THIS VALVE DESIGN CONTROLS THE FLOW WITHOUT CREATING TURBULENCE.**

The pressure control unit then compensates for the change of flow by moving the baffle to adjust the proper tip size, maintaining correct nozzle pressure. Because of this action, the patented slide valve allows the nozzle to be operated at any handle position without producing turbulence that can affect stream quality.

- Stainless steel slide valve
- Will not bind or tighten with age
- Will not tighten under high pressures
- Is always easy to open

A Handline automatic, using a unique slide-type valve design, controls the flow **WITHOUT** creating turbulence (Fig. 16a).

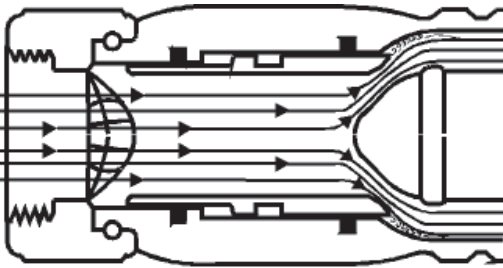

SLIDE VALVE  
*Gated 1/2 Way*

**Fig. 16a**

The pressure control then compensates for the increase or decrease in flow by moving the baffle to develop the proper tip size and pressure. A turbulence-free slide valve with automatic pressure regulation add up to “Nozzleman Flow Control”.

**Ball Valve**

Ball valves have long stood as the primary means of controlling water flow in the fire service. However widespread, they still retain problems which cannot be ignored.

Designed to be operated in a fully open or fully closed position  
Positioning other than fully open produces a violent turbulence within the nozzle  
Turbulence destroys the straight stream  
Turbulence results in surging, disrupted fog patterns (Fig. 16b)

As nozzle pressure increases:

A ball valve becomes more difficult to open  
The ball is forced harder and harder against the valve seat

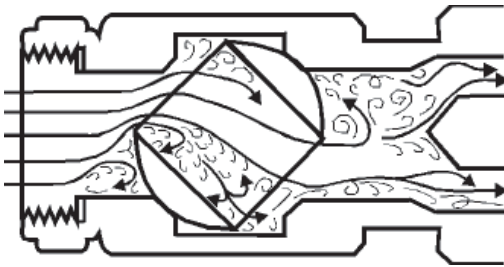

BALL VALVE  
*Gated 1/2 Way*

*Fig. 16b*

A nozzle, using a ball valve CANNOT control the flow without creating turbulence. A ball valve is designed to work in the fully open position. Any attempt to operate in less than the fully open position, creates a violent turbulence within the nozzle that results in poor stream quality and surging, disruptive fog patterns.

## **TRAINING CONSIDERATIONS WITH AUTOMATICS**

Any new technology or technique should be practiced and perfected on the training ground if it is to be successful in the heat of battle. Trained officers and firefighters are the single most important resource of a fire department regardless of equipment used.

When using the slide valve, the nozzle operator must be aware that by using the shutoff handle as a throttle, the flow can be gated back to a lower volume. And while working on ice, a roof ledge, a ladder, or any position where nozzle reaction is an added risk, the nozzle operator should throttle back to a safe, workable volume. The nozzle will automatically adjust. The nozzle operator now has a valuable “in-between”!

Rather than calculating a desired pressure for a given volume and hose layout (which is nearly impossible in the urgent rush of getting water), you simply pump to a standard level of pressure. Pump pressures of 150 to 200 PSI are suggested to deliver the increased, rapid knockdown flows. The flow control feature of TFT automatics allows the nozzle crew to then select the flow that is necessary. The difference in engine pressure and nozzle pressure (with the valve fully open) is the friction loss produced in moving the volume of water in that length of hose.

The basic formula for calculating engine pressure, **Pump Discharge Pressure = Nozzle Pressure + Total Pressure Loss (PDP = NP + TPL)** still applies.

**TPL = Appliance Friction Loss + Hoseline Friction Loss + Elevation Pressure**

With an automatic, the nozzle pressure will remain constant. The formula can then be more practically rewritten:

**Pump Discharge Pressure = 100 + TPL**

Example:

For a 500 ft. length of 2-1/2” hose, what engine pressure will be required to flow 300 GPM @ 100 PSI?

Since appliance friction loss and elevation pressure loss are not applicable: **TPL = FL = CQ<sup>2</sup>L**

FL = Hoseline friction loss in PSI  
 C = Coefficient based on hose size  
 Q = Flow in hundreds of GPM  
 L = Length in hundreds of feet

$$\text{TPL} = (2)(3)^2(5)$$

$$\text{TPL} = 90 \text{ PSI}$$

$$\text{PDP} = 100 + \text{TPL}$$

$$\text{PDP} = 100 + 90$$

$$\text{PDP} = 190 \text{ PSI}$$

Rules of thumb, slide charts and tables (Appendix A) can be used to convert a friction loss figure to a corresponding flow (Chart B).

The pump operator should be aware that the pump discharge pressure will fluctuate as a result of the nozzle operator throttling the handline. Once the desired engine pressure is attained, the relief valve or governor should be set. **Avoid “chasing” the pump pressure!!**

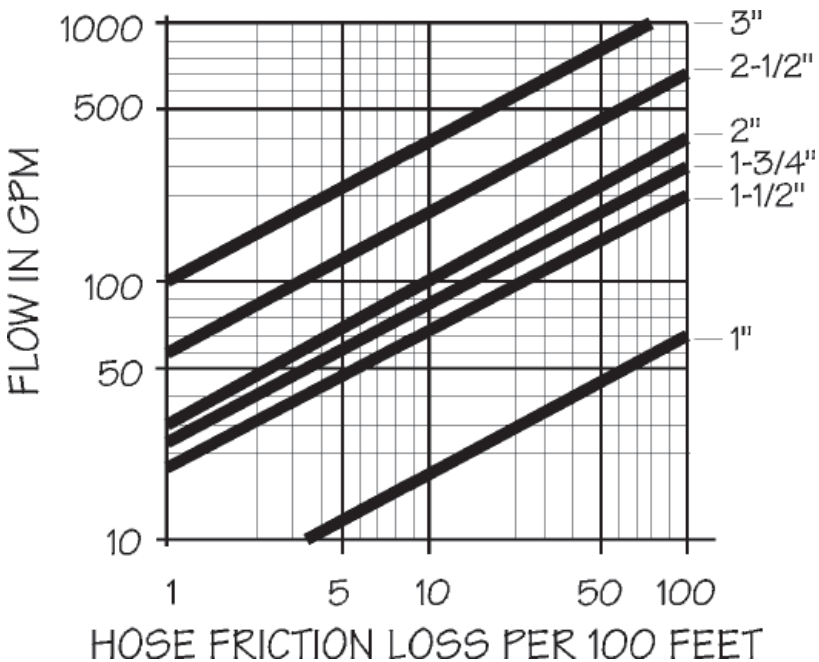

Chart B

**The rule to remember is that automatics do EXACTLY as calculated with “standard” hydraulics when calculations are correct.** Natural laws cannot be violated. Where conventional calculations and assumptions (such as available water) are incorrect, if conditions are such that desired calculations cannot be achieved, or other errors are made, the automatic nozzle will compensate for the difference. The pressure control mechanism adjusts for the actual flow. This will provide the best possible stream for the supply and conditions at that moment. Multiple streams are automatically coordinated and can be controlled to distribute the available volume most effectively.

## **USING LARGER SIZE ATTACK LINES**

People vary in size and strength and may work on various footings. Sometimes no more than one or two firefighters are available to hold an attack line. To compensate for these variables, a nozzle with a wide flow range and “Nozzleman Flow Control” is essential. The question of larger attack lines and higher flow rates has received a lot of publicity in the past. Should we use them? Certainly, with an increase in hose diameter, there will be a marginal increase in the weight and size of an attack line. For its few drawbacks, the larger line has two overwhelming advantages. **Firepower and Time!** The 1-3/4” or 2” line, while retaining most of the handling benefits of the 1-1/2” line, approximate or exceed flows usually achieved of the standard 2-1/2”. A 2-1/2” hose line is simply overkill for the flows a typical hose crew can hold.

Let’s take for example: A certain fire will require 125 gallons of water to absorb the heat and to extinguish the blaze. With a booster line at 25 GPM, an application rate of five minutes or more will be necessary. A standard 1-1/2” line flowing 125 GPM, requires 1 minute. A 1-3/4” line flowing 250 GPM requires only 30 seconds!

During the time of application, the fire generates additional heat and consumes more fuel. The lower rates (the 25 GPM booster, for example) may not stop it even after the full five minutes. Firefighters can't press the attack. As the flow increases, the actual amount of water required will also decrease, so that the actual volume required will be significantly less than the expected 125 gallons. This is due to the effect of the blitz attack--**Hitting it hard and fast!**

Nozzles with "Nozzleman Flow Control", in combination with larger size preconnected lines, add a new dimension to the term "fire attack". Big line flows, with fast, small line handling are now available. Well-trained firefighters and teamwork are still a must, but available personnel can now get in faster with more attack capability.

With 1-3/4" line at 200 PSI pump pressure, flows are available up to:

230 GPM on 150 foot preconnects  
200 GPM on 200 foot preconnects  
175 GPM on 250 foot preconnects

These flows are practical maximums for this size line. With "Nozzleman Flow Control", these flows can be reduced at the nozzle to fit the need or situation.

## **BOOSTER TANK OPERATIONS**

At first one may cringe at such high flow rate capabilities or procedures. "But we've only got 500 gallons in our tank!"; "Just two minutes on one line, one minute with a pair!" With training and experience, that's not the way it goes. After a quick preconnect stretch to the seat of the fire, a blitz attack flow is delivered. A 10-15 second blast produces a tremendous effect, with steam penetrating the same channels as the fire. A room of intense fire can be quenched using only 50 or so gallons. By repositioning, another shot can be delivered.



A booster size line wouldn't have phased it, and a conventional 1-1/2" flowing continuously might have taken several minutes and several hundred gallons of water to control the first room, if at all. Two firefighters can maneuver a 1-3/4" far more rapidly than four can muscle a 2-1/2".

Move-hit! Move-hit! Even the 500-gallon tank is spread out over the first critical minutes with unbelievable results. By that time, a supply line from a hydrant or tanker should be connected. If this blitz attack hasn't controlled the fire, or at least bought time to supplement the supply, NO WAY could an effective attack have been made with smaller lines.

## **SHAPING THE FIRE STREAM PATTERN**

The automatic nozzle shapes the fire stream from straight stream, for reach and penetration, to fog patterns, for greater heat absorption, firefighter protection, and specialized applications. However, there is more to shaping a fire stream than turning the bumper.

Fog or spray-type nozzles have been in use since the 1940's. Most of these fog nozzles had one trait in common. They all relied on stream impingement or some form of fog teeth to produce the wide fog pattern.

The earliest style of fog nozzles used had square-faced metal teeth (Fig. 17a). Two problems existed: 1) the square-faced teeth left gaps or "fingers" in the fog pattern which allowed heat to pass, and 2) the metal teeth were susceptible to damage when dropped or used as a "forcible entry tool".

The next generation of fog nozzles used spinning teeth (Fig. 17b) which appeared to eliminate the fingers of the wide fog. The spinning teeth reshaped the fingers that were visible (high speed photographs show that they are still there) with a wider and thinner fog pattern.

The wide, thin pattern spreads the available water out beyond practical use. Maximum width should be just wide enough to cast a dense shadow of protection for the hose crew. All droplets are extremely fine and can be rapidly carried away. Spinning teeth do not direct water to the center of the pattern. The teeth are often made of plastic and are easily damaged or broken.

A later development, the double row of teeth (Fig. 17c), attempted to fill the gaps between the teeth by creating another point of deflection. However, the second row formed “fingers” of its own and, therefore, left gaps in the pattern.

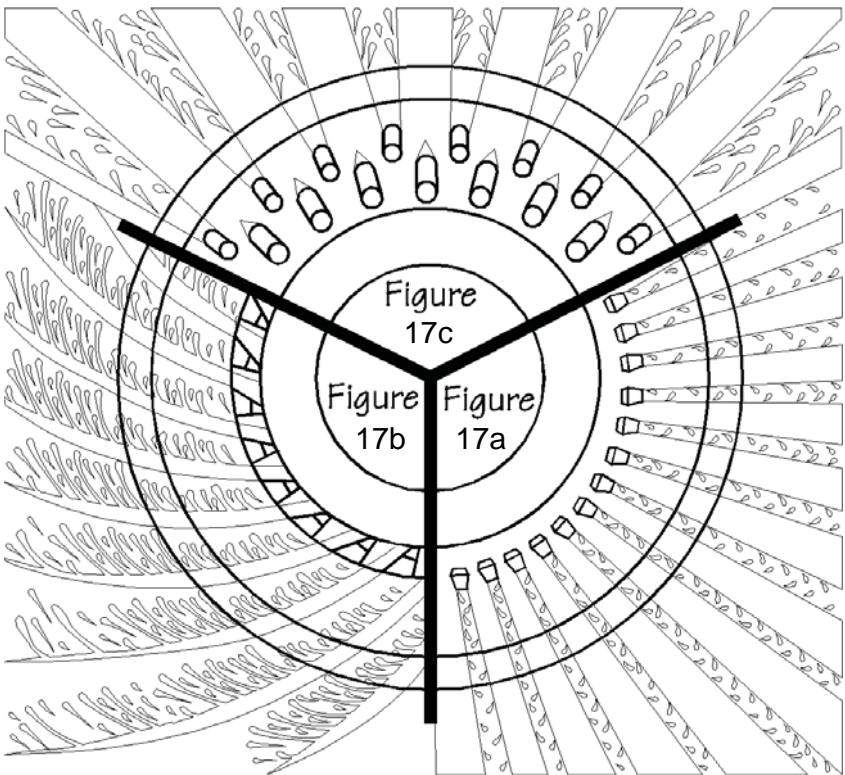

The latest innovation uses molded rubber fog teeth as an integral part of the bumper. The strong, pliable fog teeth resist damage by springing back to their original shape after impact. The thick rubber bumper aids in protecting these fog teeth, which are essential to producing a good fog pattern.

The use of computer-aided design in the development of the TFT Handline automatic (released Sept.,1983) has allowed the creation of the only fog pattern that has full-fill to the cone without fingering (Fig. 18). Each fog tooth has been shaped to form a small nozzle with the proper stream spread so as to overlap the next tooth. The face of the bumper is specially engineered to “pull” the water to a wider pattern. The tremendous pulling effect can be seen when slowly moving from partial fog to the wide fog pattern.

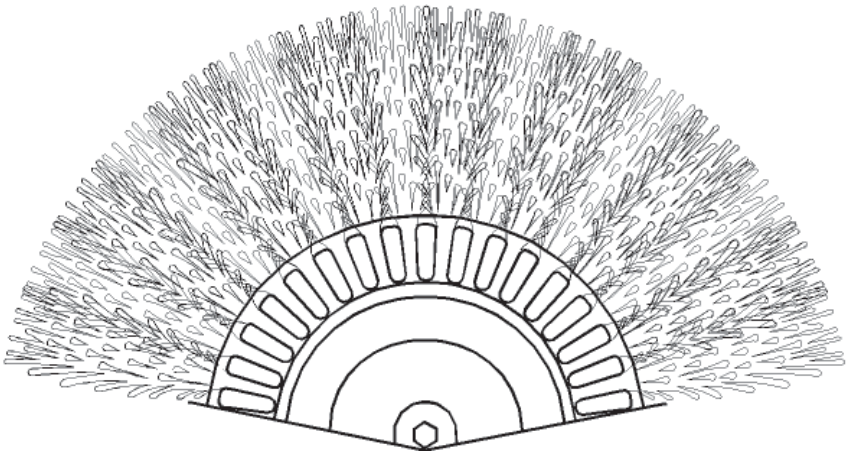

**Fig. 18**

The rubber tooth is designed to produce a wide range of droplet sizes, from moderately coarse to extremely fine. The pattern has maximum heat absorption, due to the fine droplets, yet produces large droplets for maximum reach and projection.

The combination of these two effects provides a densely-filled cone of water. This outer cone blends with the inner ball of water created from the fronts of the fog teeth to form a “POWER FOG”.

*For additional information, dial 800-348-2686 and talk to a nozzle specialist.*

## SMOOTH BORE vs. FOG TIP

It is still mistakenly believed that for a high wind, or for maximum reach, a “straight stream” or “smooth bore nozzle” is required, though it does not have the flexibility of an adjustable fog nozzle.

By design, a fog nozzle at proper pressure will produce a straighter straight stream than a smooth bore tip. The foundations of tradition quake! Why? A smooth bore stream at correct operating pressure has a greater velocity at the center than at the sides. This is due to the sidewall friction or turbulence of the water along the sides of the tip (Fig. 19a). As the water exits the nozzle, the stream has a tendency to separate and peel away from itself. The stream is truly “solid” for only a few inches. At very low pressures, the separation is not as evident (the “glass rod”); however, the stream is totally ineffective for firefighting.

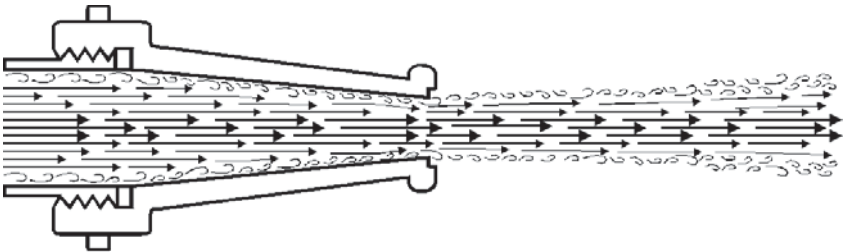

UNEQUAL VELOCITY OF SMOOTH BORE

*Fig. 19a*

A fog nozzle at proper operating pressure exits the periphery at equal velocity across the stream. A partial vacuum within the pattern is created which will focus the stream together a short distance from the nozzle (Fig. 19b). The re-converged stream has a uniform cross-sectional velocity which results in a tighter, more coherent stream with more firefighting action.

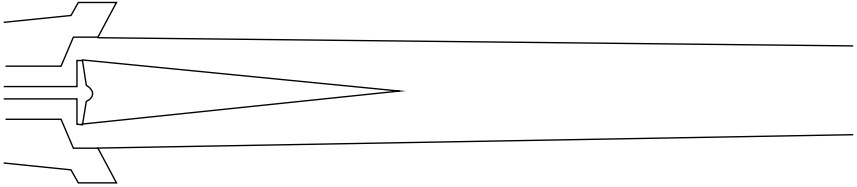

*EQUAL VELOCITY OF FOG TIP*

*Fig. 19b*

In all probability, many readers will be skeptical. So we ask that you go out and prove it to yourself. A PROPERLY TRIMMED peripheral fog nozzle delivers a straighter, tighter, more far-reaching stream than the “smooth bore”.

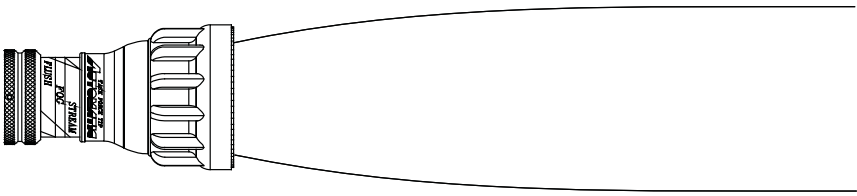

*NARROW FOG*

*Fig. 20a*

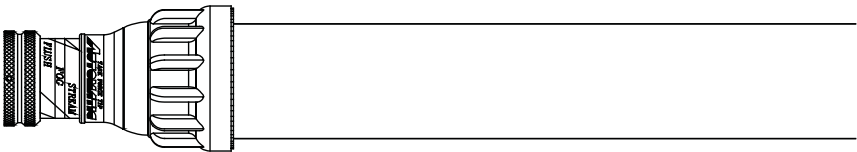

*CORRECTLY TRIMMED STREAM*

*Fig. 20b*

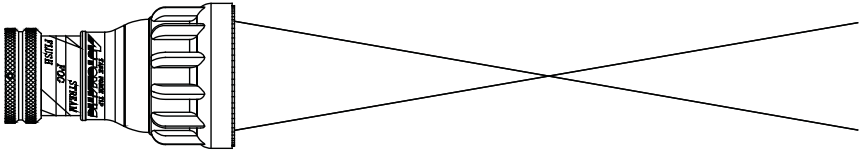

## PAST STRAIGHT STREAM

*Fig. 20c*

Proper trim is the key, and that is the point where the pattern is just closed. For example, for the longest reaching, sharpest straight stream, the shaper sleeve is rotated toward fog until the pattern starts to widen (Fig. 20a); then it is turned back enough to close the stream to parallel (Fig. 20b). To advance the shaper farther will cause the stream to cross over the focal point and degrade the stream (Fig. 20c).

## FLUSHING DEBRIS

Another necessary feature of a fog nozzle is the ability to flush unwanted debris. Stones, gaskets, tank scale, etc., can all seriously affect the operation of the nozzle. The pressure-assisted flush allows debris up to 5/16" to pass through the nozzle by a simple twist of the shaper past wide fog (Fig. 21).

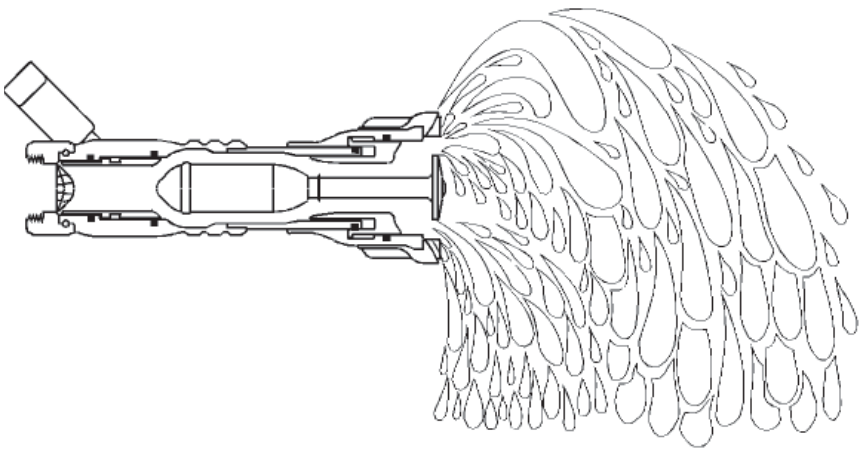

*Fig. 21*

The built-in inlet screen “Gasket Grabber” is located in the back of the nozzle and should be checked after each use. Any debris caught in the “Gasket Grabber” should be removed after each nozzle use.

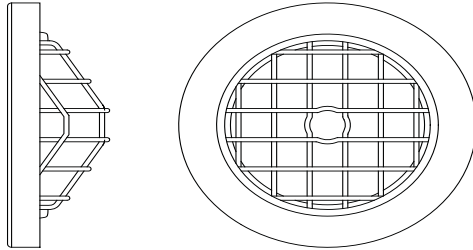

*Fig. 22*

## **NOZZLE REACTION**

Considerable attention has been given throughout this booklet to nozzle pressures and the effects of reaction. Newton’s Third Law of Motion states, “For every action there is an equal and opposite reaction.” Nozzle reaction is best known to firefighters as nozzle “kickback”. Simply, at equal nozzle pressures, a higher volume will have a higher reaction. At equal flows, a greater nozzle pressure will produce a greater reaction. This law creates a problem with conventional non-automatic nozzles. Once the rated flow is reached, slight increases in GPM produce rapid gains in nozzle reaction.

### **1-1/2” Fog Nozzles**

For example, let’s look at a conventional 1-1/2 inch fog nozzle rated at 100 GPM. At the rated flow (100 GPM), the nozzle pressure would be 100 PSI. To increase the flow to 110 GPM, a nozzle pressure of 120 PSI would be required. For a flow of 120 GPM, the required nozzle pressure would be 145 PSI; and at 130 GPM, the nozzle pressure would be a whopping 170 PSI.

To translate these nozzle pressure/flow combinations to nozzle reaction, the following common formula is used for fog nozzles — **NR = (0.0505)(QNP)**

- Where: NR = Nozzle reaction in pounds
- 0.0505 = A constant
- Q = Flow in GPM
- NP = Nozzle pressure in PSI

With this formula we calculate that the nozzle reaction for each of the above flows is:

- 100 GPM = 50 lbs. NR
- 110 GPM = 61 lbs. NR (+10% flow, +22% reaction)
- 120 GPM = 73 lbs. NR (+20% flow, +46% reaction)
- 130 GPM = 86 lbs. NR (+30% flow, +72% reaction)

With a conventional fog nozzle (Chart C), once the rated flow is attained, nozzle reaction will increase at a rate **more than twice** as fast as flow (Chart D).

### 100 GPM FOG TIP

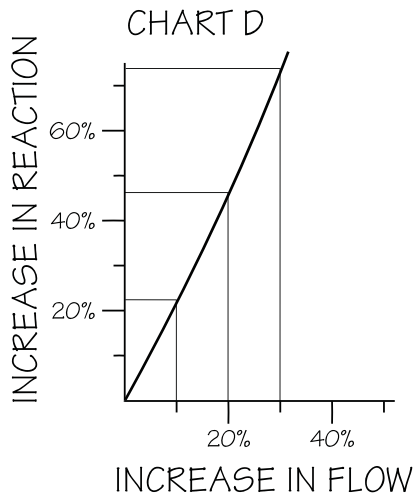
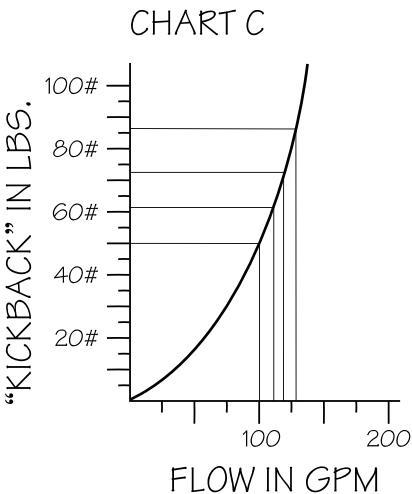



## 2-1/2" Fog Nozzles

A conventional 250 GPM fog nozzle on 2-1/2" hose exhibits the same reaction characteristics as the 100 GPM fog nozzle when operated above its rated flow. For example:

250 GPM = 126 lbs. NR (100 PSI NP)  
275 GPM = 153 lbs. NR (+10% flow, +21% reaction)  
300 GPM = 182 lbs. NR (+20% flow, +44% reaction)  
325 GPM = 214 lbs. NR (+30% flow, +70% reaction)

Shown graphically in charts E & F.

### 250 GPM FOG TIP

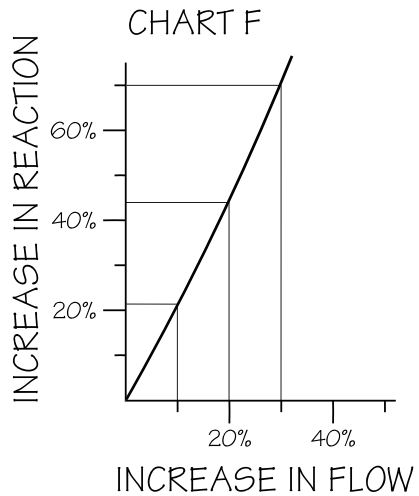
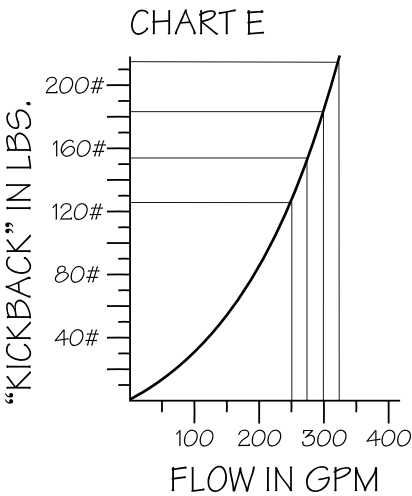

## Smooth Bore Tips

Smooth bore nozzles are subject to the same rules for nozzle reaction as conventional fog nozzles. Both types of nozzles have a fixed size opening. Above the rated flow, the nozzle reaction will climb faster than the increasing flow. Neither will produce a significant increase in flow. The same nozzle reaction formula for fog nozzles can be applied to smooth bores, but is more commonly rewritten as:

$$NR = (1.57)(d^2NP)$$

Where: NR = Nozzle reaction in pounds  
1.57 = A constant  
d = Nozzle diameter in inches  
NP = Nozzle pressure in PSI

Smooth bore nozzle reaction also increases at a rate more than twice as fast as flow. In either case, with conventional nozzles, the nozzle reaction and pressure increase drastically to attain a marginal increase in flow.

Remember, the reason that the nozzle reaction increases so dramatically with conventional nozzles is that the nozzle pressure must increase with an increase in flow. The discharge opening does not change. **The real culprit in nozzle reaction is the nozzle pressure!!**

### Automatic Nozzles

Automatic nozzles have the ability to keep nozzle reaction at a minimum for any given flow by maintaining a constant nozzle pressure.

Using the same flows as the previously mentioned 2-1/2" fog nozzle, and the same  $NR = (0.0505)(QNP)$  formula, the nozzle reaction for an automatic would then be:

250 GPM = 126 lbs. NR  
275 GPM = 139 lbs. NR (+10% flow, +10% reaction)  
300 GPM = 152 lbs. NR (+20% flow, +21% reaction)  
325 GPM = 164 lbs. NR (+30% flow, +30% reaction)

Note that with an automatic nozzle (Chart G), the increase in nozzle reaction is equal to the increase in GPM. A 10% increase in GPM produces a 10% increase in nozzle reaction. A 20% increase in GPM produces a 21% increase in reaction, and a 30% increase in GPM produces an equal 30% increase in nozzle reaction (Chart H).

# AUTOMATIC NOZZLES

CHART G

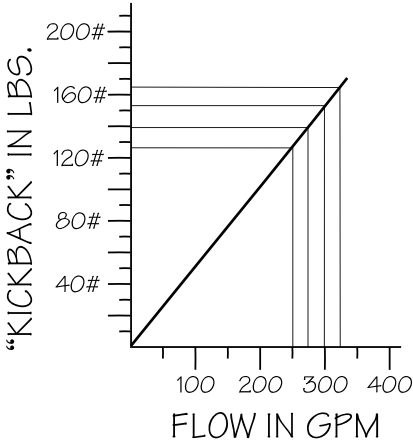
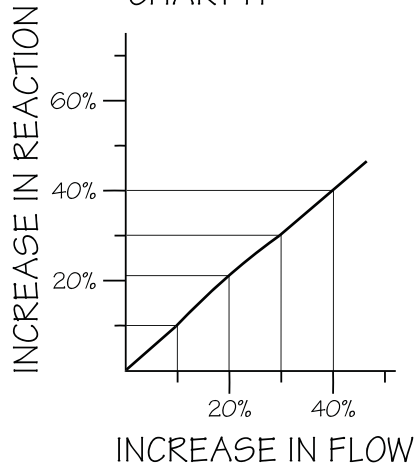

CHART H



Just from the information above, it makes sense to use an automatic nozzle. With the formula that is used to determine nozzle reaction for fog nozzles ( $NR = 0.0505 \times Q \times NP$ ), and a constant nozzle pressure of 100 PSI, an easy rule-of-thumb calculation would then be  $NR = 1/2 \text{ GPM}$ .

The nozzle reaction from a fog nozzle will also vary with the stream pattern. The greatest nozzle reaction will be in the straight stream pattern.

As the nozzle reaction increases with any nozzle, an equal or greater amount of counter-reaction must be produced to keep the nozzle stationary. In most firefighting operations, this counter-reaction is supplied by the firefighting crew. (See Nozzle Reaction Chart at rear of book.) Just how much water can this team flow and still maintain control of the hose line? From past experience and experimentation, flows of 150 to 250 GPM are workable volumes for automatics on preconnected hose lines with a two-person attack team.

Should the nozzle reaction become excessive for a lone operator, the TFT Automatic is the **ONLY** nozzle that allows the nozzle operator to adjust the flow and, therefore, the nozzle reaction without affecting the nozzle pressure or stream quality. Think about it the next time you are working on a ladder or other dangerous location. Varying firefighter capabilities and situations makes the ability to control flow and resulting reaction a vital necessity in using the higher flow rates to maximum advantage.

## **DUAL-FORCE / MID-FORCE** **(Dual-pressure Automatic Nozzle)**

TASK FORCE TIPS created the first dual pressure automatic nozzle to address a new need in the fire service. This need is to allow the firefighter to override the automatic pressure control (100 PSI) and obtain an increased flow (GPM) at a lower nozzle pressure in **certain situations**.

This latest feature allows the nozzle operator to very quickly change the operating pressure of the nozzle from the “STANDARD” 100 PSI to a low pressure setting of about 60 PSI. By changing the Nozzle Pressure additional friction loss in the hose is overcome allowing more flow to pass. (Refer to ***DUAL-FORCE and MID-FORCE*** flow/pressure charts in appendix.)

### **Standard Pressure Operation**

The Dual Pressure Automatic nozzles have a redesigned pressure control unit that accurately and consistently maintains the desired nozzle pressure of 100 PSI, as specified in NFPA #1964 for automatic nozzles. The ***DUAL-FORCE*** has the unique distinction of being “the first automatic nozzle to meet NFPA #1964 flow standards for automatic nozzles”. Each nozzle has been completely tested for total compliance by both third party contractors and TFT’s engineering staff. Complete test documentation is available by visiting our web site [www.fts.com](http://www.fts.com).

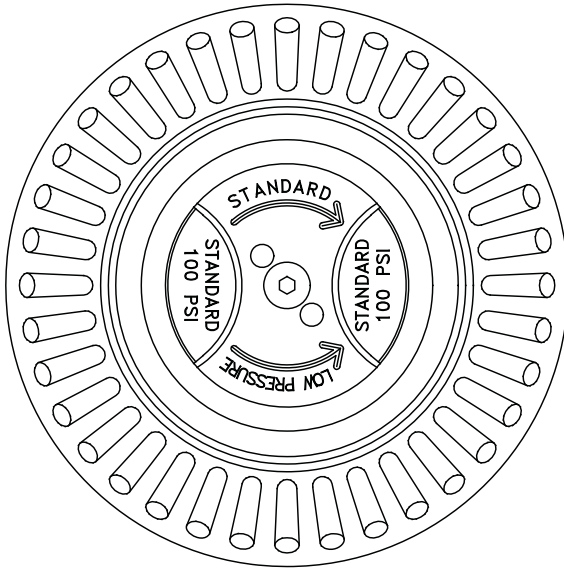

**Standard Pressure Operation**

*Fig. 23*

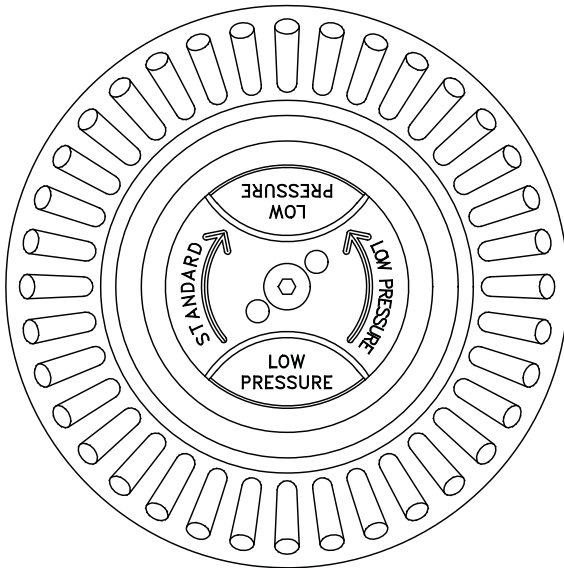

**Low Pressure Operation**

*Fig. 24*

## **Low Pressure Operation**

By a simple twist of the knob, located on the baffle at the front of the nozzle, the **DUAL-FORCE and MID-FORCE** goes into low-pressure between 55 PSI and 75 PSI (depending on GPM flow).

**NOTE:** The initial opening of the **DUAL-FORCE** opens wider to improve very low pressure operations. Think of the low-pressure mode as switching the nozzle to the equivalent flow of a 3/4" smooth bore. However, from 65 PSI on up, instead of the nozzle pressure increasing drastically (like on a smooth bore), the **DUAL-FORCE** increases the opening as more GPM is delivered. The **DUAL-FORCE** acts like an elastic smooth bore increasing in size as the flow increases (Refer to the **DUAL-FORCE** flow/pressure chart in appendix).

## **Low Pressure Setting Applications**

There are certain fireground situations when adequate pressure cannot be supplied to the nozzle. When this occurs, the nozzle cannot "open up" and allow for adequate flow. We recognize that the ability to override the pressure control unit would be desirable in certain unusual situations.

This may include one or more of the following:

1. Incorrect pump operation.
2. Pump transfer valves jammed or not fully changed over.
3. Kinked hose line.
4. High elevation losses/long hose lays (high-rise).
5. "Pressure reducing valves" in high-rise building applications.
6. "Stolen" flow by conventional nozzles or large caliber streams.
7. Pumper breakdown/pump failure.

# AUTOMATIC NOZZLES AND FOAM

Automatic nozzles can be used with great success for foam applications providing certain guidelines are followed. Foam-making is simply adding the proper amount of foam concentrate to water. This solution of concentrate and water is then mixed with air (aeration) at the nozzle to form a finished foam product.

## Foam Type

The types of foam that work well with a non-aspirated fog nozzle (conventional or automatic) are synthetic AFFF foam, "Class A" and synthetic detergents. All foams will work much better when an aspirating attachment is used.

## Foam Concentration

Once the proper type of concentrate is selected, it must be mixed in the right proportion with water. Proper injection of foam concentrate with water is the single most important element to good foam-making. If a foam eductor is used for foam proportioning, the nozzle flow must match the capacity of the eductor, and the mixture setting on the eductor must be set to match the foam concentrate.

## Foam Proportioning

Eductors are pre-engineered systems and require specific pressures for operation. The eductor manufacturer's recommendations for hose size, length, and pump pressure should be followed. The automatic nozzle will adjust itself to the GPM rating of the eductor.

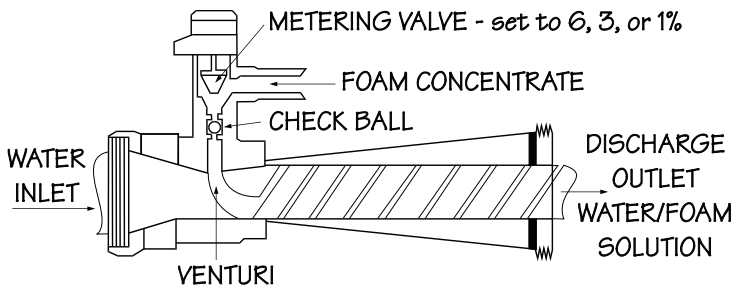

**Fig. 25**

With **ANY** eductor system, the nozzle valve **MUST** be fully open to allow proper flow across the eductor at the venturi. This produces the vacuum necessary to pick up the foam concentrate and mix it into the water.

This can be used to your advantage if only water is needed at the nozzle. By partially throttling the nozzle, a back pressure is created at the eductor, and the foam concentrate is not picked up, allowing for water only to be discharged at the nozzle.

### **Batch Mixing**

The nozzle operator may operate the valve on the automatic nozzle in any desired position and the concentrate ratio will remain constant at all flows.

### **Around-the-Pump Proportioning Systems**

High flow rates and multiple hose lines may be used. Like the single eductor, the nozzle operator **MUST** keep the valve on the nozzle **FULLY OPEN**.

### **Discharge-Side Proportioning System**

The desired concentrate ratio is maintained at all flow rates up to the maximum capacity of the concentrate pump. Once selected, the concentrate ratio will automatically be injected into the water stream and will not be affected by variations in hose, length, pressure, or elevation. The nozzle operator may operate the valve on the nozzle in any desired position and the concentrate ratio will remain constant at all flow rates.

### **Nozzle Operation**

Now that we have the right type of foam mixed in the right proportion, with either discharge-side or around-the-pump proportioning, an eductor, pre-mixed in the booster tank, or some other method, let's focus on proper nozzle operation for optimum foam-making capability.



Assuming operation will be from the pre-mixed booster tank, the procedure will be similar to pulling a preconnect for structural firefighting. A 150 foot 1-1/2" line can have a foam flow of 150+ GPM at a pump pressure of 200 PSI; a 1-3/4" preconnect can flow 200+ GPM at the same pump pressure. A pre-piped deluge gun with a Master can flow in excess of 400 GPM. This option allows considerably more knockdown potential than a 60 or 95 GPM eductor. Although this procedure may not be necessary for every situation, it does give large and small fire departments high foam application rate capability without additional specialized equipment. In addition, with the pre-mixed method, the nozzle operator using a handline can now adjust his flow to what he needs, unlike operations with an eductor.

To gain the maximum reach and, at the same time, produce the maximum expansion ratio of the foam/water solution, the nozzle should be adjusted to a very narrow 10-15 degree fog pattern. Wider fog patterns will result in a thinner foam with a lower expansion ratio. The expansion ratio is the amount of finished foam produced to the volume of solution used to generate the foam. Foam manufacturers currently recommend an 8 to 1, up to 11 to 1, expansion ratio. For example, an 8 to 1 expansion ratio means 800 gallons of finished foam is produced from 100 gallons of the foam concentrate/water solution.

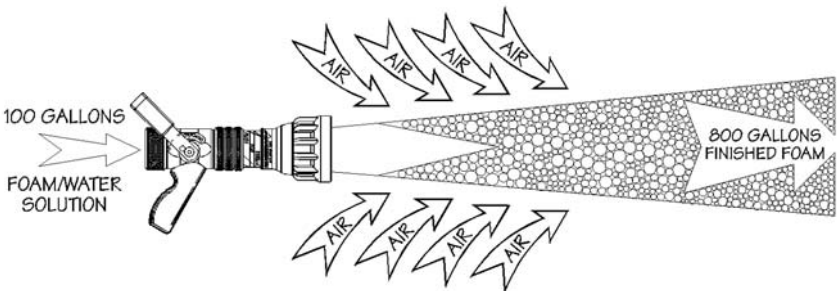

**Fig. 26**

With the use of a TFT Foamjet, TFT Foamjet-LX or TFT MX-Foamjet aspirating attachment, automatics will produce an expansion ratio between 8 and 14 to 1.

By maintaining a constant nozzle pressure, the automatic will keep the velocity of the stream high. Large amounts of air are pulled into the stream and mixed with the foam/water solution at the end of the stream. This mixture of air and foam solution expands and “snowflakes” down lightly on the burning surface. Additional expansion can be created by deflecting the foam stream on a horizontal or vertical surface further entraining air and increasing the foam expansion. A foam stream should not be directed into a flammable liquid as this may cause splashing of the fuel and possible injury. TFT automatic handline nozzles have an excellent performance record when used for structural firefighting. If these guidelines are followed, they will perform with excellent results as foam-making nozzles.

## **MASTER STREAM AUTOMATICS**

During major fire situations, the quick application of large volumes of water is necessary to effect control and extinguish the blaze. Larger fires will also require the resources of additional firefighters and equipment. The command and coordination of these units become increasingly difficult as the tactical plan is put into action. The incident commander soon realizes that the success of his strategy is largely dependent on the success of the fire streams.

In a fire situation where the water supply is known to be less than desirable, it would be necessary to begin the attack with a small tip size to deliver the available flow. If the water supply is improved, will the tip size again be changed to accommodate the new flow? What if the supply available is shared with other fire streams? Will the correct tip sizes be selected to make the best use of the water supply for that

moment? Can the proper pump pressure be determined quickly for each layout?

The TFT Master Stream automatic nozzle was developed out of the need to coordinate master streams at multiple alarm and mutual-aid fires. The water supply and pumping capability at these incidents varied from unlimited to virtually nonexistent. In addition, it was not unusual for the water supply to fluctuate as pumpers tapped into common sources or when relays were established to improve the supply. The scenario has changed little, but the automatic has had a significant effect on the outcome.

Master Stream nozzles have a wide flow range of 150-1250 GPM. Like all automatics, the pressure control mechanism of the Master Stream will maintain a nozzle pressure of 100-105 PSI throughout the wide flow range of the automatic nozzle.

The combination of the wide flow range and pressure control make the Master a practical choice for aerial ladders, aerial platforms, portable monitors and pre-piped deck guns. A single Master can take the place of several different nozzle sizes (Fig. 27).

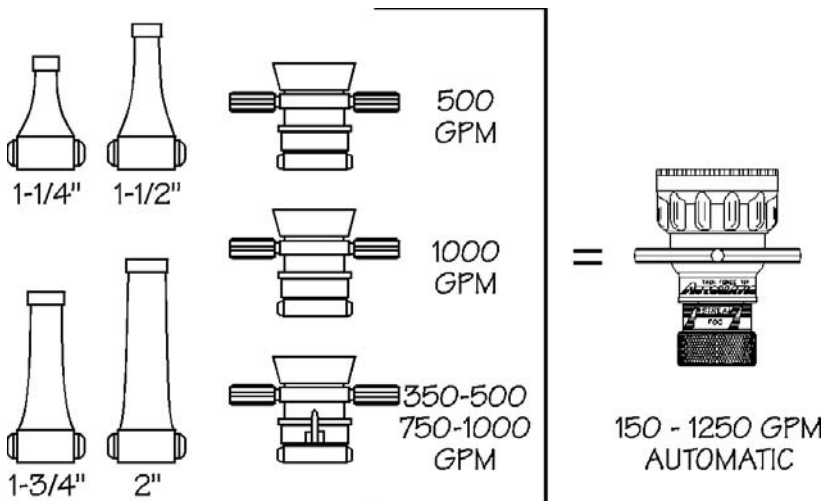

**Fig. 27**  
41

The coordination of master streams is greatly simplified when using automatics. For additional information, dial 800-348-2686 and speak to a nozzle specialist.

## THE WATER TRIANGLE CONCEPT

The simplified hydraulics of the automatic nozzle can easily be remembered as a “Water Triangle” (Fig. 28).

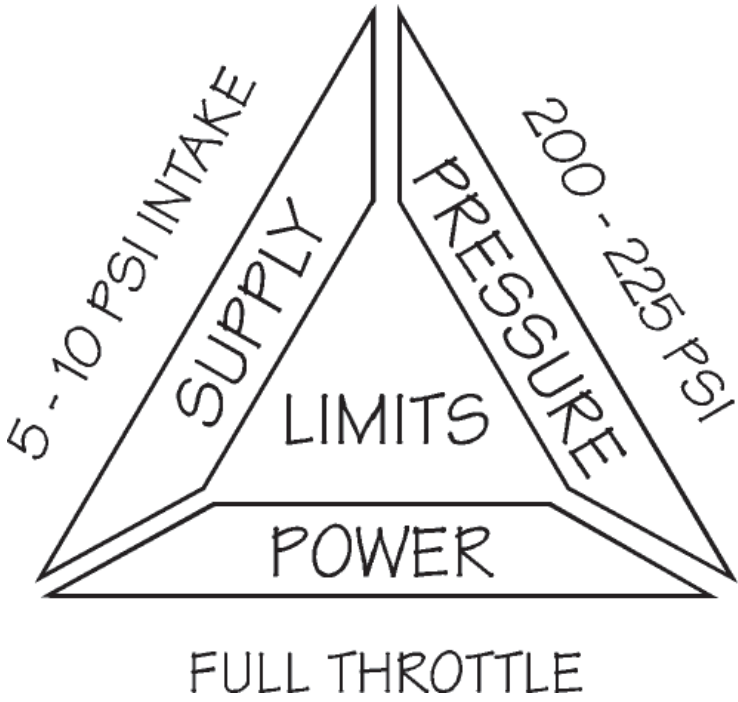

Fig. 28

Each side of the triangle represents one of three limits to any pumper setup. They are 1) water supply, 2) pumper power, and 3) maximum allowable working pressure. Working the pumper to whichever of the limits is reached first produces the maximum possible delivery for that particular layout.

When pumping into an automatic nozzle, the pump operator throttles out until he reaches a limiting side of the triangle. These limits would show as:

**1) WATER SUPPLY:** indicated by 5 - 10 PSI on the inlet gauge or by the suction hose going slightly soft. It can also show as the engine tending to “run away” (speed up erratically).

**2) PRESSURE:** indicated by the limiting pressure, usually 200 - 225 PSI showing on the pumper discharge pressure gauge.

**3) POWER:** indicated by running out of throttle.

While these limits will yield the maximum for a particular layout, this is not to say that the layout shouldn't be improved! If working against the pressure limit, adding parallel or large-diameter lines will greatly increase flow. If water supply is the problem, improvement is necessary on the suction side of the pump. This can be accomplished with larger suction lines, additional lines into the pump, or receiving water from an additional source (relay pumping). The power limit is reached only at high volume, usually when supplying over-capacity to one or more streams. The load can be shared with a second pumper by shifting lines. The second pumper can be worked in tandem off the same hydrant with the first. Additional parallel or large-diameter lines can be used to reduce friction loss.

Although the same limits apply to a pumper when working with “conventional” tips, merely working to the system limit does not produce desired results unless the tip size is exactly correct. If the regular tip size is too large, a poor, under-pressured stream is all that can be obtained. If the regular tip is too small, the stream will be over-pressured, failing to deliver the volume available using the correct size tip.

With automatic nozzles, the pump operator can achieve maximum efficiency as fast as he can adjust his throttle. The automatic is simultaneously adjusting the “tip size” to best deliver the available water.

All this is very simple: **YOU DON'T FOOL MOTHER NATURE!** Working with automatics will maximize Mother Nature's laws to the ultimate with optimum results assured faster and more accurately than with conventional nozzles.

## **CONCLUSION**

Increased fire loads, hazardous materials, and reduced personnel are serious problems which we face in the 21st Century and beyond. However, we must still respond. Saving lives and protecting property continue to be our primary objectives.

Recent changes in hose sizes for both supply and attack has allowed more water to be applied in less time. Only with an automatic nozzle will you benefit from these changes. The TFT family of automatics can improve your fire-suppression capabilities and, at the same time, simplify and standardize fireground operations.

An effective fire stream is the desired end result of any water, pump, hose, and nozzle combination. The automatic assures you of this by making constant adjustments to match the current water supply.

No matter how fine your firefighters, equipment or training, the success of your efforts depends on the working ends of your hose lines. Either you have the best possible streams with maximum control, or the rest of your efforts are in jeopardy.

*For additional information, call 800-348-2686 and speak to a nozzle specialist.*

## EMAIL & FAXABLE LITERATURE

With the implementation of TFT's ON LINE LIBRARY, you can receive valuable information 24-hours a day through your computer or fax machine.

Information on new products, current products, maintenance procedures, product specifications, product comparisons, firefighting techniques, reports, and new ideas is as close as your fingertips.

To access this service, go to [www.tft.com](http://www.tft.com) and enter the On Line Library. Find the information you need and decide if you want to view it on line, email yourself a copy or send it to your fax machine.

*For additional information on our On Line Library or any other firefighting topic, call 800-348-2686 and speak to a nozzle specialist.*

## APPENDIX

### 10 Common Questions About Automatic Nozzles

#### 1) *How is an automatic nozzle different from a regular (conventional) nozzle?*

Conventional fog nozzles are nozzles that have a fixed or selectable GPM setting. These GPM settings correspond to a particular discharge orifice or “tip size”. In order for a conventional nozzle with a fixed opening to operate at the correct nozzle pressure (100 PSI), the proper flow (GPM) must be supplied. For example, a selectable gallonage nozzle with settings of 30-60-95-125 GPM will only deliver these flows at 100 PSI nozzle pressure.

If the proper fire stream is attained, the flow to that nozzle cannot be altered unless the discharge opening is changed for the new flow (larger for a higher flow and smaller for a lower flow). Since conventional nozzles cannot change size and are limited in adjustment, one of two things must happen.

The first possible result occurs when the conventional nozzle is supplied less than the rated or selected flow. This results in a weak, ineffective stream. The situation may be due to poor water supply, long hose lays, improper selection of tip size, or pump operator error. This under-pressured stream may waste water because the velocity needed to reach the seat of the fire is not produced. Little, if any, knockdown capability is achieved.

The second possible result occurs when the conventional nozzle is supplied more than the rated or selected flow. This results in excessive nozzle pressure. The excessive flow will produce a much higher than normal nozzle pressure and, therefore, a corresponding increase in reaction or “kickback”. This higher reaction will make the hose line more difficult to handle and may jeopardize the safety of the nozzle crew.



In addition, the potential extra water available, evidenced by the high nozzle pressure, is not delivered effectively. A large size discharge orifice for the extra water is required (changing gallonage setting). The high flow, if delivered to the correct size opening, results in a reduction in nozzle reaction, a reduction in the pump pressure, and produces a fire stream at the proper pressure. With an automatic nozzle, the discharge orifice is continually variable depending on the flow to the nozzle. This allows the flow being supplied to be delivered at the proper nozzle pressure and correct velocity for maximum extinguishing capability. Some of the benefits of automatic nozzles are as follows:

**Constant Hard-Hitting Streams:** To obtain the proper “punch” that is necessary for an aggressive attack, an automatic maintains the optimum nozzle pressure at all times. The fire stream is unaffected by upstream variables that may be unknown to the pump operator or hose crew.

**Proper Nozzle Pressure With Available Flow:** With changing water supplies, the automatic will adjust to the flow available and use the water most effectively. If the flow to the nozzle is increased, the automatic will increase the discharge opening to accommodate the higher flow. In situations where water supply is not adequate, or when sufficient lines have not been established to move the water available, the automatic will adjust to make best use of the supply until the system can be improved. If water supply to the nozzle is reduced, the automatic will decrease the size of the discharge orifice and the same nozzle pressure will continue to be maintained.

**Maximum Reach With Available Water:** To gain the greatest reach with a fire stream, maximum flow must be delivered at the correct pressure. By maintaining the nozzle pressure at 100 PSI, automatic nozzles will always produce the maximum reach possible with the available water supply.

**Higher Initial Flow Rates:** The limiting factor to maximum flow delivery with conventional hose lines is usually the nozzle. If the water is available, we normally attempt to deliver the rated capacity of the nozzle. More water can only be supplied to the conventional nozzle at the risk of higher nozzle pressure and kickback. Excessive pump pressures would also be necessary to compensate for the increased friction loss and the higher than normal nozzle pressure. With an automatic nozzle, an increase in pump pressure is all that is necessary to move a higher flow. The nozzle pressure remains constant; therefore, the extra engine pressure overcomes additional hose friction loss produced by the higher flow.

## **2) *How does an automatic nozzle work?***

The automatic nozzle uses a principle very similar to that of a pumper relief valve. A highly dependable spring, connected to the baffle which forms the discharge orifice, is balanced against the water pressure in the nozzle. The pressure control (spring) senses the increase or decrease in pressure within the nozzle. It then moves the baffle in or out to maintain a particular “tip size” necessary to keep the nozzle pressure at 100 PSI. In effect, the nozzle is constantly changing “tip size” to match the water being supplied at that moment. This allows the flow being supplied to be delivered at the proper nozzle pressure and velocity.

## **3) *What pressure do we pump to automatic nozzles?***

Automatic nozzles greatly simplify pump operation. Since automatic nozzles are designed to operate at 100 PSI nozzle pressure, this becomes the minimum starting point for any operation. The basic formula for calculating pump discharge pressure is  $PDP = NP + TPL$ , where PDP is the pump discharge pressure, NP is the nozzle pressure, and TPL is the total pressure loss (hoseline friction loss + apparatus friction loss + elevation pressure).

With an automatic, the nozzle pressure will remain constant and the formula can be rewritten as:  $PDP = 100 + TPL$ .

Example: For a 200 foot preconnect of 1-3/4" hose, what pump pressure will be required to flow 150 GPM? (Friction loss in 1-3/4" hose for 150 GPM is about 28 PSI per 100 feet of hose.)

$$PDP = NP + TPL$$

$$PDP = 100 + TPL$$

$$PDP = 100 + (2 \times 28)$$

$$PDP = 100 + 56$$

$$PDP = 156$$

To flow 150 GPM in the above layout, a pump discharge pressure of 156 PSI is required. The required pump pressure will vary depending on the friction loss produced, the amount of flow desired, and the length and size of the hose lay. Your department can determine specific pump pressures in advance for various flows required for different operations. A well-involved house fire will require a higher pump pressure for initial knockdown than the same fire during the overhaul stages.

Once standard operating procedures (SOP's) are established, standard friction loss tables for various hose lines can be used to develop pump discharge pressure criteria based on the  $PDP = NP (100) + TPL$  formula. One department in particular, that uses 200 feet of 1-3/4" preconnects, uses the following SOP for pump discharge pressure... 200 PSI for initial attack when a working fire is found with a visible flame, 150 PSI when nothing is showing and a line is taken in for investigation, and 125 PSI during overhaul. These pump discharge pressures will provide flows of approximately 200 GPM, 150 GPM and 125 GPM respectively.

The advantage of using TFT automatic nozzles, in the previous application, is that any flow can be delivered by the pump operator and still be controlled by the nozzle operator. Variable flow, constant nozzle pressure, and “Nozzleman Flow Control” are three essential elements to successful fire streams and fire attack.

#### ***4) How do I know how much water I am flowing?***

Much of the information in question three can be used to determine flow from the nozzle using standard hydraulics calculations. We have already determined that, with an automatic nozzle, the nozzle pressure will remain at or near 100 PSI. By subtracting the known nozzle pressure of 100 PSI from whatever the pump discharge pressure is (assuming there is no pressure loss due to elevation), the friction loss can be determined. By dividing the friction loss by the number of hundred feet of hose in the hose lay, a value for friction loss per hundred feet is determined. This can then be compared to any standard friction loss chart for the size of hose being used and a corresponding flow found.

For example: A hose lay consisting of 300 feet of 2-1/2” hose and an automatic nozzle is being pumped at 145 PSI. The first step is to subtract the known nozzle pressure of 100 PSI (for automatics) from the pump discharge pressure (145 - 100). This leaves 45 PSI for friction loss. The next step is to divide the friction loss by the number of hundred feet of hose; in this case,  $45/3 = 15$ , or 15 PSI friction loss per 100 foot of hose. By referring to a standard friction loss chart for 2-1/2” hose, 15 PSI loss per hundred feet corresponds to a flow of 250 GPM. (All we have done is rearrange the formula used in question three to determine pump discharge pressure.)

Then  $PDP = NP + TPL$  becomes  $TPL = PDP - NP$ ; and since NP is always 100 PSI with automatics, it is more simply written as  $TPL = PDP - 100$ .

The rule to remember is that automatics do exactly as calculated using “standard” hydraulics. Natural laws cannot be violated. Unlike conventional nozzles where the nozzle pressure changes with the GPM flow, automatics will maintain the nozzle pressure at 100 PSI. This known factor can be “plugged in” to the standard formulas to deliver a certain amount of water, or be used to determine the flow when pump pressure and hose lay are known.

### ***5) What is the flow from each “Click Stop” on the nozzle?***

All TFT handheld automatic nozzles have a feature called “Nozzleman Flow Control”. The slide valve in these nozzles is unique. In addition to acting as a shut-off valve, it can also be used to regulate the flow at the nozzle without affecting the stream quality. The handle, on these nozzles, controls the valve movement and, therefore, the flow. Where the handle contacts the valve body, a series of six detents act to maintain handle position at any of the selected settings.

Moving the handle from the fully closed position, six detents or “click stops” are felt. Since TFT standard and dual-pressure automatics are variable flow nozzles, the maximum flow (fully open) is determined by the pump engine pressure and hose lay. It is possible for the same handline automatic nozzle to flow 95 GPM if used on a 1-1/2” line, or as high as 300 GPM if used on a 3” line. Because the maximum flow is different each “click stop” would have a different value. Changing the engine pressure on the same 3” line to get a maximum flow of 200 GPM, will again change the flow at each “click stop”.

The “click stops” were not developed to have specific flows from each setting, but rather to maintain handle position as the nozzle operator reduced or increased the flow at the handle.

### **6) Can I use automatics with foam and foam eductors?**

If the eductor manufacturer's recommendations for inlet pressure, maximum hose length and size are followed, the automatic nozzle will adjust itself automatically to the rating of the eductor. With ANY eductor system, the nozzle valve **MUST** be fully open to prevent excessive back pressure on the eductor which will prevent foam concentrate pickup.

TFT automatic nozzles can be used with great success when used for foam application. Certain guidelines, however, must be followed. Foam-making is simply the addition of a proper amount of foam concentrate to water. This solution of foam concentrate and water is then mixed with air (aeration), either at the nozzle with air-aspirating attachments, or as the stream pulls air along with it, in a non air-aspirating application.

### **7) Why don't all automatic nozzles have spinning teeth?**

TFT automatic nozzles shape the fire stream from straight stream, for reach and penetration, to fog patterns, for greater heat absorption, firefighter protection, and special applications. However, there is more to shaping a fire stream than turning the bumper.

Fog or spray-type nozzles have been in use since the 1920's. Most of these fog nozzles have one trait in common. They all rely on stream impingement or some form of fog teeth to produce the wide fog pattern.

The earliest style fog nozzles used square-faced metal teeth. Two problems existed: 1) The square-faced teeth left gaps or "fingers" in the fog pattern which allowed heat to pass, and 2) The metal teeth were susceptible to damage when the nozzle was dropped or used as a "forcible-entry tool".

The next generation of fog nozzles used spinning teeth which appeared to eliminate the "fingers" of the wide fog.

The spinning teeth reshaped the “fingers” that were visible (high speed photographs show that they are still there), but produced a wider, thinner fog pattern with little or no water in the center of the pattern directly ahead of the nozzle crew. The wide, thin fog pattern is not wide enough to protect the hose crew while delivering the maximum amount of water ahead of them for protection. All droplets are extremely fine, and are rapidly carried away under intense heat. These teeth are often made of plastic and are easily broken.

A later improvement, the double row of teeth, attempted to fill the gaps between the teeth by creating another point of deflection. However, the second row of teeth created “fingers” of its own and, therefore, left gaps in the pattern.

Task Force Tips was the first to use rubber fog teeth as an integral part of the bumper. The thick rubber bumper aids in protecting the fog teeth which are strong and pliable, resisting damage by springing back to their original shape after impact. The use of computer-aided design has allowed TFT to create the only fog pattern which is sufficiently wide enough for crew protection while filling the center of the fog cone without “fingering” to the fog pattern. Each tooth has been shaped to form a small nozzle with the proper stream spread to overlap the next tooth.

### ***8) What type of nozzle is best for “Nozzleman Flow Control”?***

Let’s look at the three common nozzle types: fixed gallonage (smooth bores), adjustable gallonage, and automatics.

The fixed gallonage (smooth bore) nozzle offers the nozzle operator two choices, on or off. A ball valve shutoff device that is partially opened creates tremendous turbulence which destroys the stream and greatly reduces its effectiveness. The pump discharge pressure must be matched to the nozzle by the **pump operator**.

A selectable gallonage, “flow controlling ring”, nozzle has the same ball valve problems as the fixed gallonage (smooth bore), plus a misconception created by the “flow controlling ring”. For example: A nozzle with a 30-60-95-125 selectable “flow controlling ring” set at 60 GPM, with a 100 PSI nozzle pressure, and the ball valve fully open, will flow a usable stream. Simply turning the “flow control ring” to 95 GPM, lowers the nozzle pressure, produces an under pressurized stream, may waste water, reduces stream reach, reduces knockdown effectiveness, and does not mean you are flowing 95 GPM. Conversely, turning the “flow control ring” to 30 GPM, results in excessive nozzle pressure and a corresponding increase in reaction or “kickback”! This higher nozzle reaction makes the hose line more difficult to handle and may jeopardize the safety of the nozzle operator. To maintain proper nozzle pressure would require constant coordination with the **pump operator** and a pressure gauge mounted behind the nozzle. A selectable nozzle can be compared to an automobile’s 4-speed manual transmission.

A TFT Automatic, with patented “slide valve”, offers true “Nozzleman Flow Control”. The slide valve allows the nozzle operator to decrease or increase the flow (GPM) without creating turbulence. Because it’s an automatic, the nozzle pressure remains constant at 100 PSI. This means, that for any flow selected by the **nozzle operator**, the stream will be clean and properly pressurized, allowing the maximum reach possible for that flow. An automatic nozzle can be compared to an automobile’s automatic transmission.

The ultimate “Nozzleman Flow Control” would be the TFT Dual-Force or Mid-Force (dual-pressure automatic). This automatic nozzle offers one more advantage over all other automatics. As an automatic transmission has the ability to be locked into low gear, for certain situations, the TFT Dual-pressure automatics allow the **nozzle operator** to switch into “low pressure” as the situation demands.



**9) Is it true that the stream from a “SOLID” bore nozzle hits harder and goes farther than the “Hollow” stream from a fog nozzle?**

Absolutely false! And if you read to the end of this paragraph you will learn a method to prove this to not only yourself but anyone that believes this oldest of fire fighting myths. The fog nozzles stream is hollow for the first few inches of its reach and it is from this fact that the myth got its start. The purpose of this short hollow section is to **PREVENT** the rest of the stream from being hollow. By bringing the water to the outside and then **FOCUSING** it back into the middle the stream is made parallel and hence its tendency to spread is stopped. A smooth bore on the other hand is squeezed down progressively until the instant that it leaves the orifice. A smooth bore stream can **ONLY** expand from the instant that it leaves the nozzle. Now, for the method of proving this. All that is needed is a pitot gage and a flow meter or some other means for being **CERTAIN** that the flow out of the two nozzles to be compared is identical. (they will be at different nozzle pressures, the smooth bore at 50 psi and the fog nozzle at 100 psi) First establish the flow on the smooth bore and pitot the nozzle to make sure that its at 50 psi. Note its flow from the flow chart. Now move the pitot gage away from the nozzle attempting to maintain the highest reading possible. You will find that it will be difficult to get any reading above a few PSI. Now change nozzles to the fog nozzle (It can be any kind of fog nozzle automatic or non automatic, a manually set fog nozzle set to the same flow as the smooth bore might be easiest for this test as it will allow you to quickly set the base pressure to 100 psi to assure that an equal flow is being compared) Adjust the fog nozzle for its best straight stream which is the point where the nozzle just closes from a narrow fog without crossing over. Now again use the pitot gage to measure pressure. At the very front of the nozzle it will be difficult as the wall of water is quite thin, move away from the

nozzle to a distance of about 36 inches and hold the pitot in the stream. You should be able to easily pitot 40 to 60 psi at this distance from the nozzle. So there is the proof, which is the “Hollow Stream” the one that can’t be pitoted a few inches from the nozzle or the one that can be pitoted 3 feet away and still have more pressure than the smooth bore. It’s an easy choice to make.

***10) What’s all this talk about low pressure nozzles? What are the trade offs, is the compromise worth it?***

The final decision on this must be left with the individual department but it is important that the facts be considered when the decision is made. True enough, reducing nozzle pressure does account for some reduction in nozzle reaction. But how much reduction in pressure is required to get a significant reduction in reaction? And while reduced reaction may be a good positive aspect what are the negative aspects of choosing a low pressure nozzle delivery system? First of all lets consider the amount of reduction in reaction. The nozzle reaction is composed of two factors, pressure and volume which are related by the formula  $\text{Reaction} = .0505 \times \text{Flow} \times \text{Square Root of Pressure}$ . Many are advocating reducing the fog nozzle pressure by 1/4 from 100 PSI down to 75 PSI. If the flow is kept constant the reaction reduction from a 25% cut in nozzle pressure is 13%. (For example a 200 GPM stream at 100 psi has 101 pounds of reaction, cutting the nozzle pressure to 75 PSI only reduces the reaction to 88 pounds). Nozzle pressure is directly related to the VELOCITY or SPEED of the stream. So now instead of a stream speeding through the super heated gases at 80 miles per hour it goes through at 60 miles per hour. Which has more impact when it hits, a baseball thrown by a major leaguer player at 80 mph or a ball thrown by a little leaguer at 60 miles per hour? Which goes further? Which splashes more when it hits, which bores through the char to get to deep seated heat? The questions go on and on, if it is ok

to cut the pressure in half then why not cut it down to nothing, take the nozzle off, lay the hose in the window, and fill the building up?

Make a comparison to the trend of our police departments in the United States. As the threat to police officers goes up are they going to smaller guns, fewer bullets in the clip? Are they taking out the bullets and pouring out half the powder? If they cut out half the powder the gun would kick less, be easier to aim, and it wouldn't hit as hard. Is that what the police want for their weapons? Is this what fire departments really want for their primary weapon? Or what about an example that comes closer to home, how many people wish for a shower with less pressure and how many would think that a shower with less pressure does a better job of getting the soap off?

# TABLE 1

## FRICITION LOSS COEFFICIENTS -- SINGLE LINE

Hose Diameter and Type (inches)	Coefficient (C)
3/4" booster	1,100
1" booster	150
1-1/4" booster	80
1-1/2" rubber line	24
1-3/4" with 1-1/2" couplings	15.5
2" rubber lined with 1-1/2" couplings	8
2-1/2" rubber lined	2
2-3/4" with 3" couplings	1.5
3" with 2-1/2" couplings	0.8
3" with 3" couplings	0.677
3-1/2"	0.34
4"	0.2
4-1/2"	0.1
5"	0.08
6"	0.05
<b>Standpipes</b>	
4"	0.374
5"	0.126
6"	0.052

*Reprinted with permission from the Fire Protection Handbook, Copyright 1986, National Fire Protection Association, Quincy, MA. 02269.*

### **PUMP DISCHARGE PRESSURE:**

$$\text{PDP} = \text{NP} + \text{TPL}$$

PDP = Pump discharge pressure in PSI

NP = Nozzle pressure in PSI

TPL = Total pressure loss in PSI

$$TPL = FL + EP + AFL$$

- FL = Hoseline friction loss in PSI
- EP = Elevation Pressure
- AFL = Appliance friction loss in PSI

### **HOSELINE FRICTION LOSS:**

$$FL = CQ^2L$$

- FL = Hoseline friction loss in PSI
- C = Friction loss coefficient (from Table 1)
- Q = Flow rate in hundred of GPM (Q = GPM/100)
- L = Hose length in hundred of feet (L = Feet/100)

### **ELEVATION PRESSURE:**

$$EP = .5H$$

- .5 = A constant
- H = Height in feet

### **NOZZLE REACTION:**

#### *Smooth Bore Nozzle*

$$NR = (1.57) (d^2NP)$$

- NR = Nozzle reaction in pounds
- 1.57 = A constant
- d = Nozzle diameter in inches
- NP = Nozzle pressure in PSI

#### *Fog Nozzle*

$$NR = (0.0505) (Q \sqrt{NP})$$

- NR = Nozzle reaction in pounds
- 0.0505 = A constant
- Q = Flow in GPM (Note: This is not gpm/100)
- NP = Nozzle pressure in PSI

As a rule of thumb, use the following nozzle pressures to ensure safety and efficiency:

Solid Bore Nozzle (Handline)	--	50 PSI
Solid Bore Nozzle (Master Stream)	--	80 PSI
Fog Nozzle (All Types)	--	100 PSI

Pressure loss for elevated master streams and turret pipes will vary depending on the manufacturer of the device.

# NOTES



**TASK FORCE TIPS, INC.**

3701 Innovation Way • Valparaiso, IN 46383-9327  
800-348-2686 • 219-462-6161 • Fax 219-464-7155