



US006868845B1

(12) **United States Patent**
Moore

(10) **Patent No.:** **US 6,868,845 B1**
(45) **Date of Patent:** **Mar. 22, 2005**

(54) **AUTOMATIC LOADING CROSS-BOW**

5,544,641 A * 8/1996 Jenn 124/25
5,596,976 A * 1/1997 Waiser 124/25
5,598,829 A * 2/1997 Bednar 124/25

(76) Inventor: **Ralph J. Moore**, 12227 Lynda Dr.,
Houston, TX (US) 77038

* cited by examiner

(*) Notice: Subject to any disclaimer, the term of this
patent is extended or adjusted under 35
U.S.C. 154(b) by 0 days.

Primary Examiner—John A. Ricci
(74) *Attorney, Agent, or Firm*—The Matthews Firm

(21) Appl. No.: **10/704,100**

(22) Filed: **Nov. 7, 2003**

(51) **Int. Cl.** **F41B 5/12**

(52) **U.S. Cl.** **124/25**

(58) **Field of Search** 124/25

(57) **ABSTRACT**

An improved automatic loading cross-bow comprising a main frame having pivotally mounted interchangeable bow limbs adjacent to its front end. The bow limbs can be latched in a folding position, for easy transportation, in an extended position for firing, or can be interchanged for different bow weights. The cross-bow includes an arrow magazine containing a plurality of arrows adapted to be attached to the main frame. An improved spring device automatically feeds arrows, one at a time, into the firing position in the main frame as the bow string is cocked. An improved safety release trigger is adapted to be cocked by moving the bow string into firing position and to be fired only when the safety release and trigger are both actuated. The improved release trigger further provides for a smooth center line firing.

(56) **References Cited**

U.S. PATENT DOCUMENTS

3,739,765 A * 6/1973 Moore 124/25
3,968,783 A * 7/1976 Pfotenhauer 124/25
4,722,318 A * 2/1988 Yankey 124/25
4,827,894 A * 5/1989 Schallberger 124/25
4,877,008 A * 10/1989 Troubridge 124/25
5,119,797 A * 6/1992 Anderson 124/25
5,243,956 A * 9/1993 Luehring 124/86

17 Claims, 8 Drawing Sheets

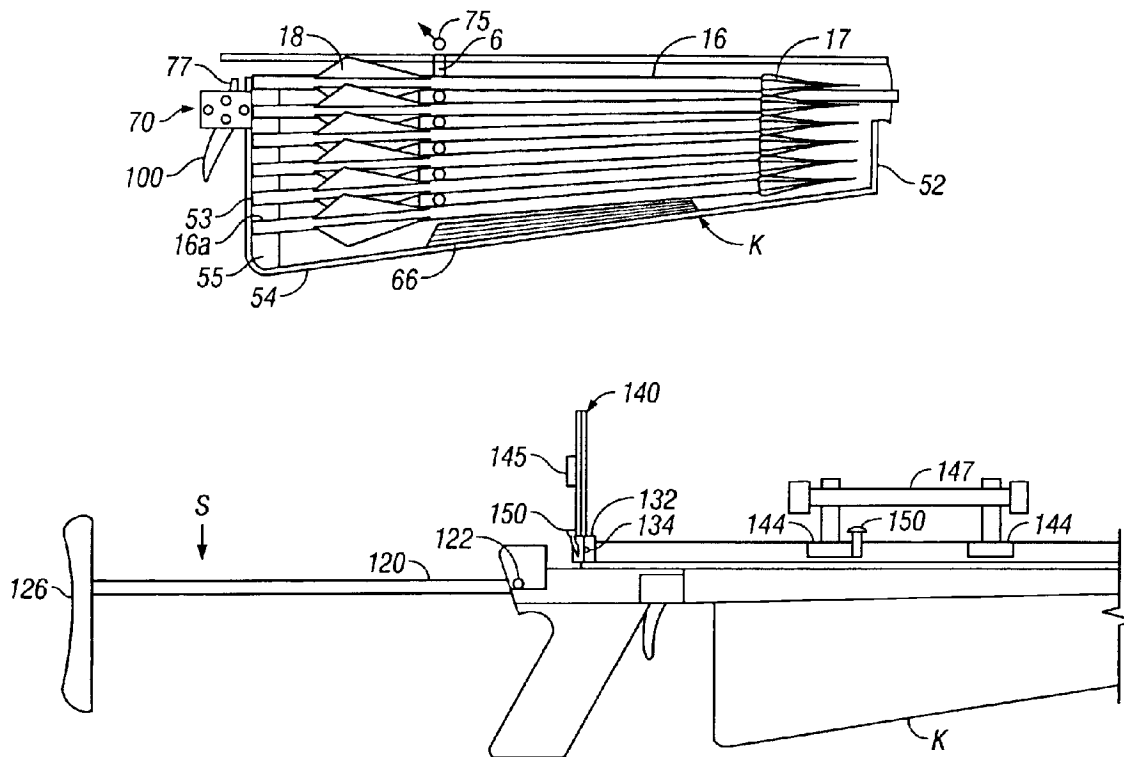

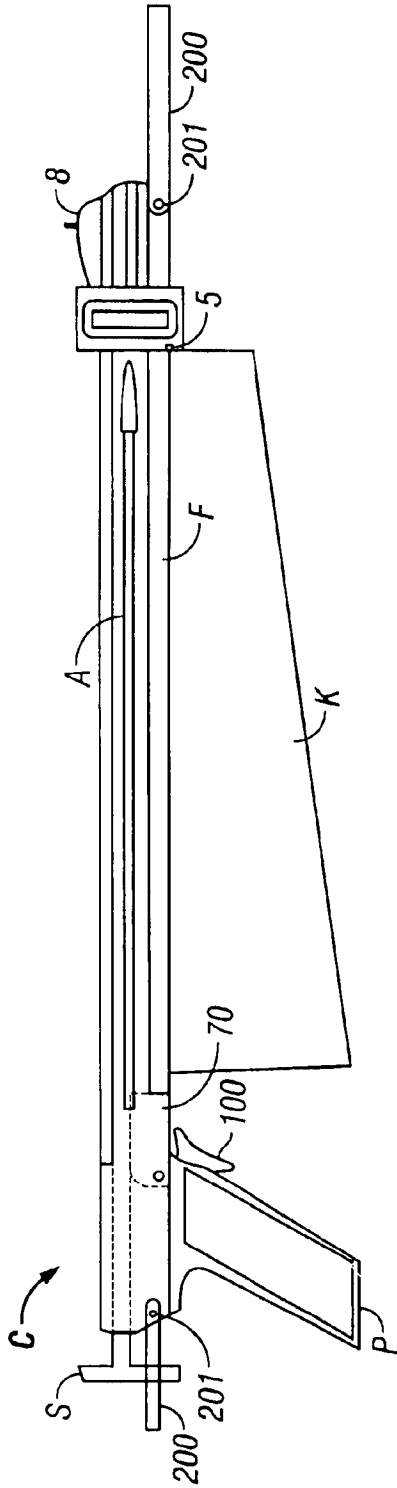

FIG. 1

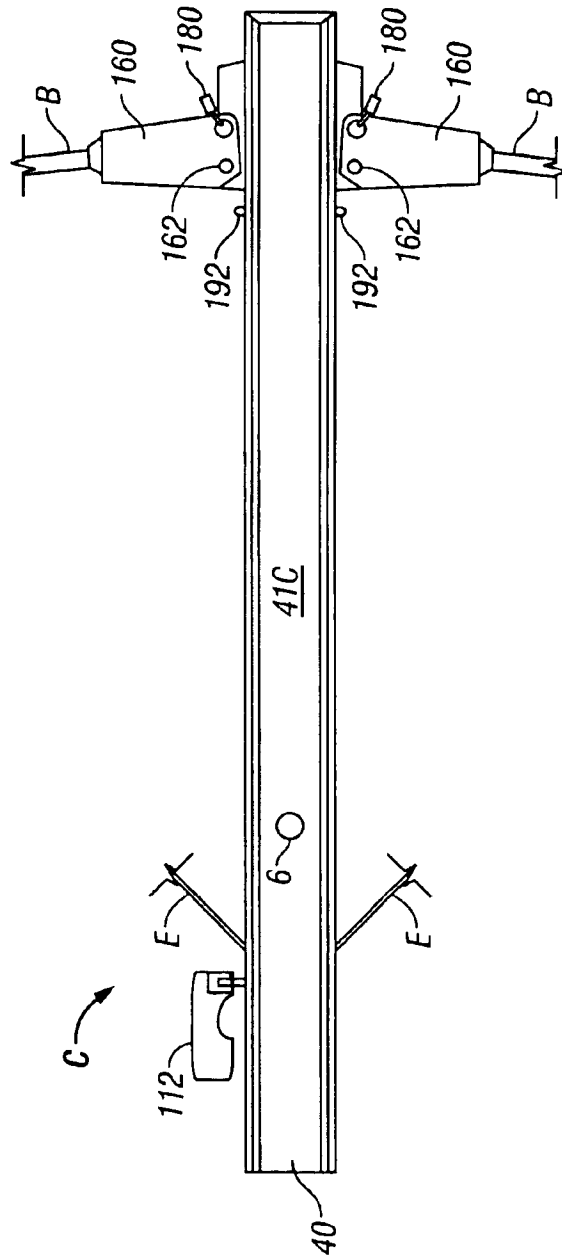

FIG. 2

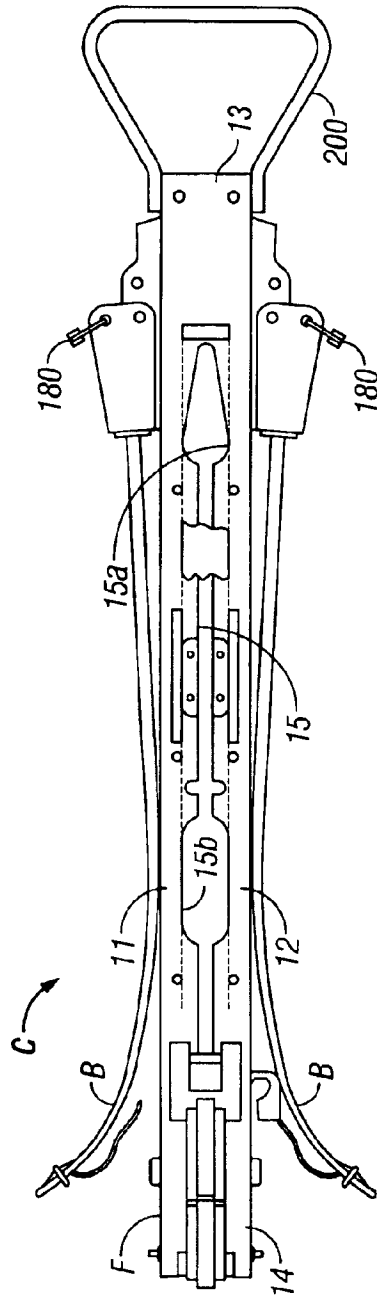

FIG. 3

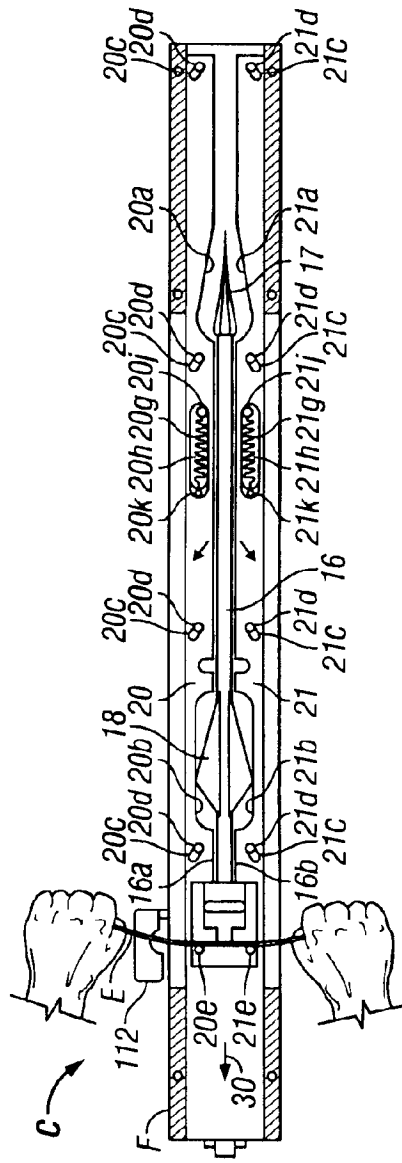

FIG. 4

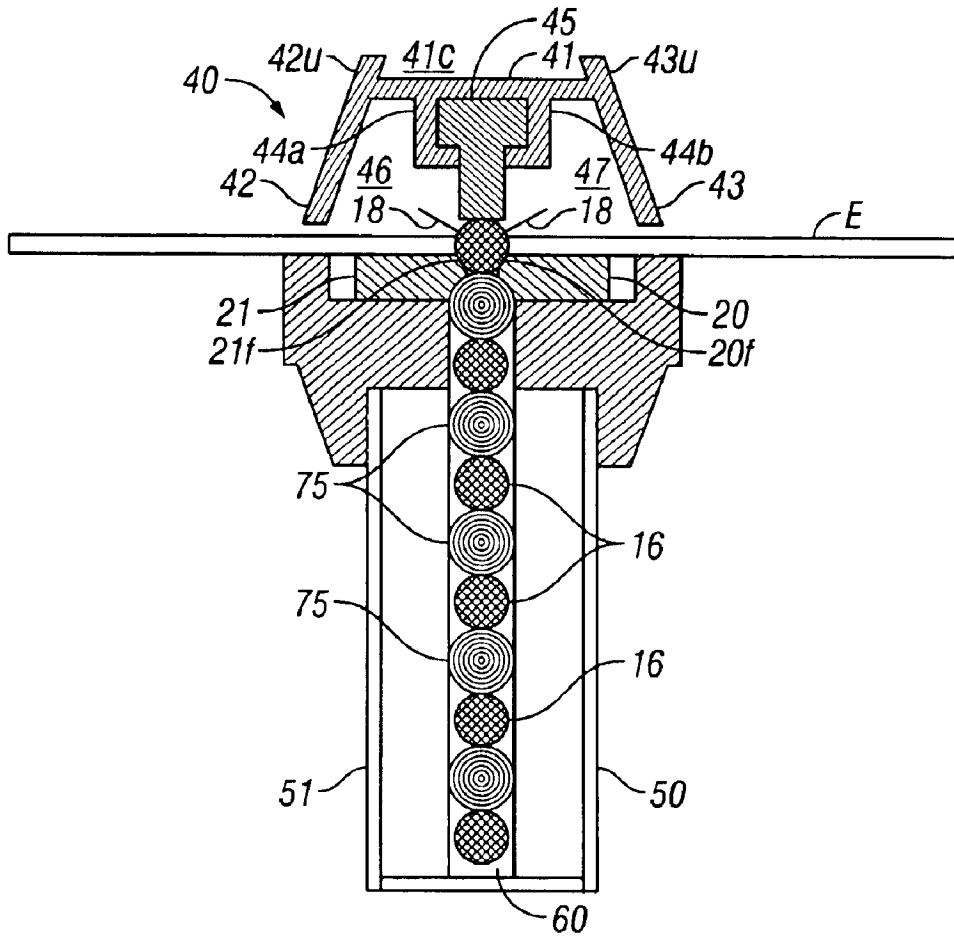

FIG. 5

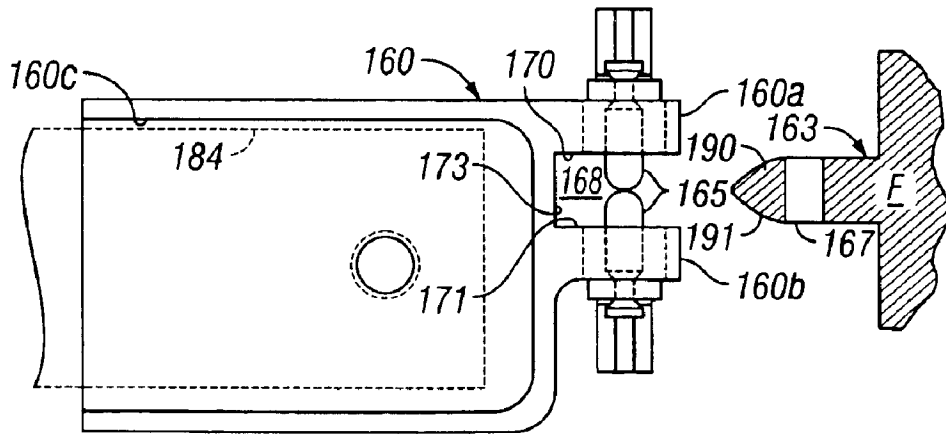

FIG. 6

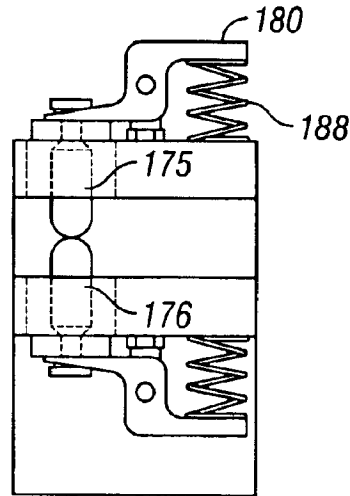

FIG. 6A

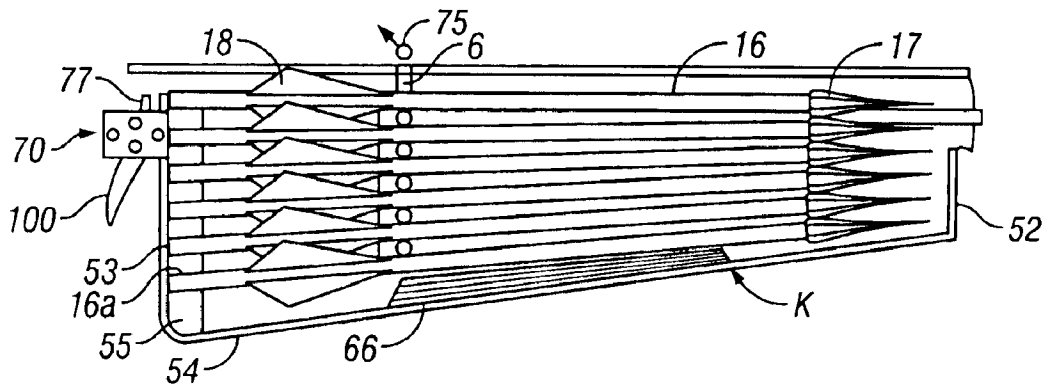

FIG. 7

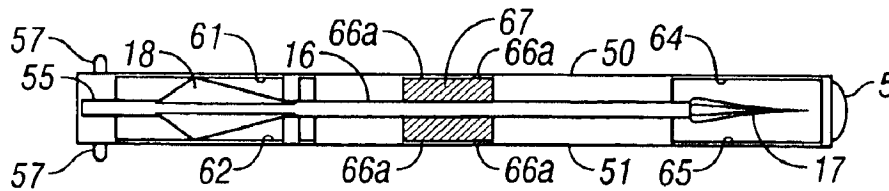

FIG. 8

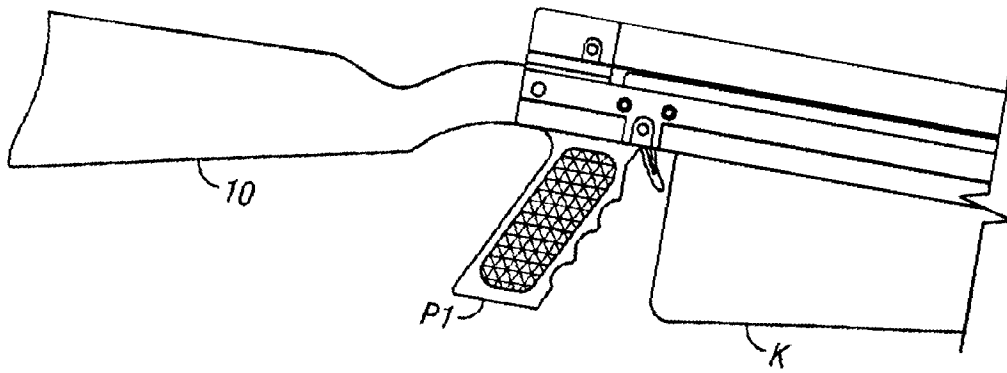

FIG. 9

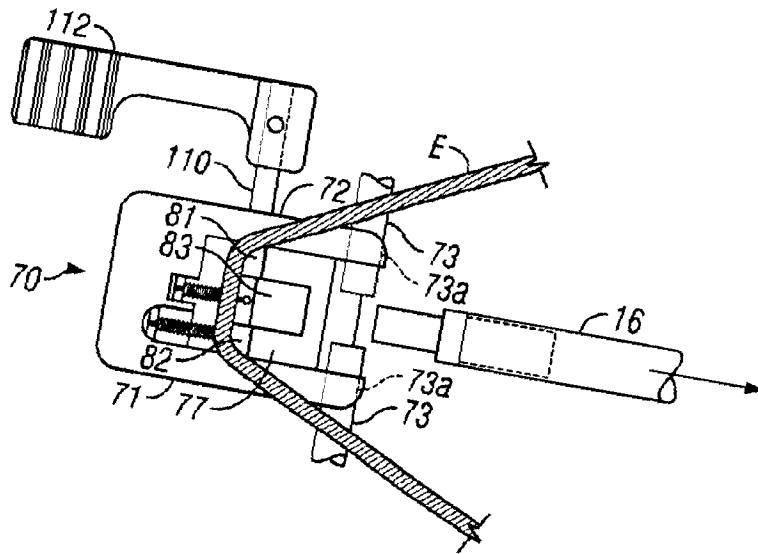

FIG. 10

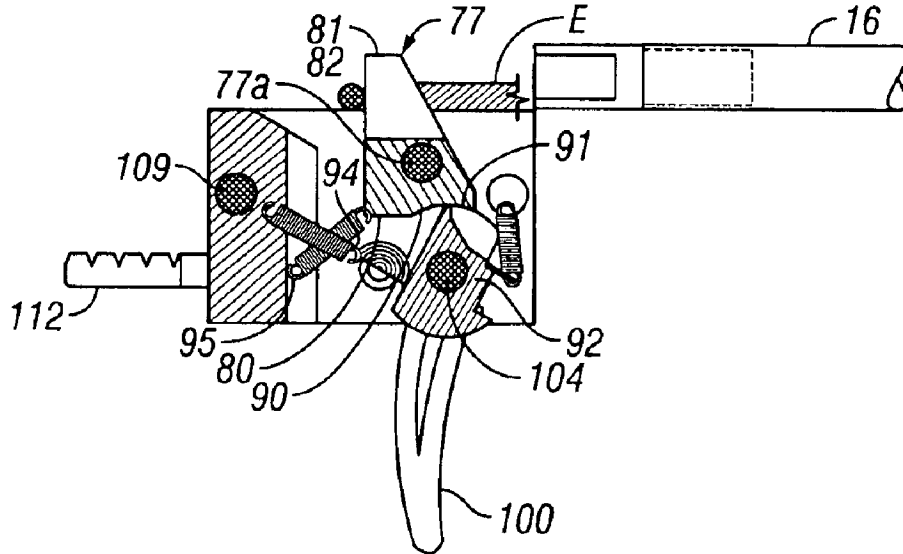

FIG. 11

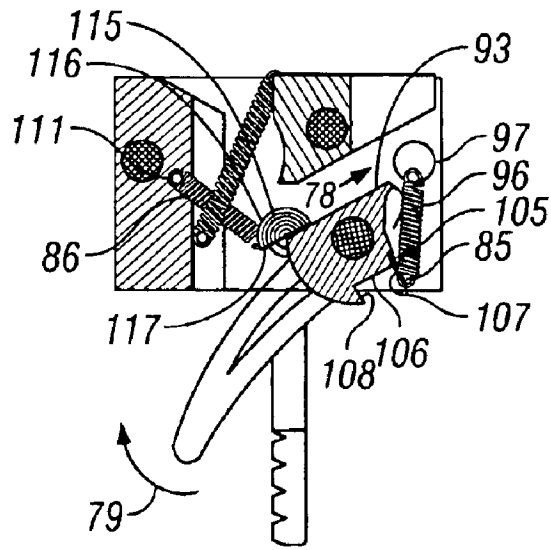

FIG. 12

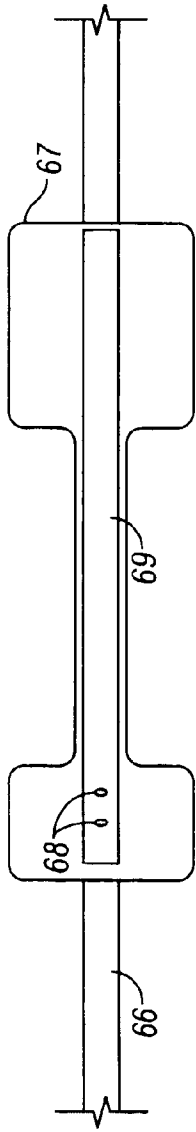

FIG. 13

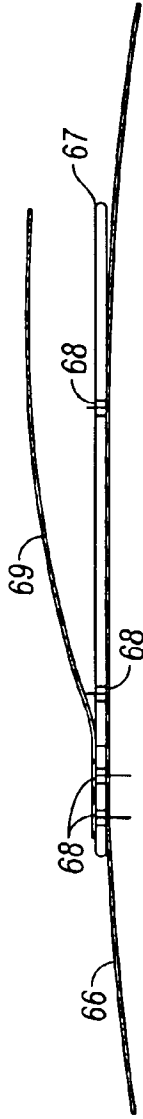

FIG. 13A

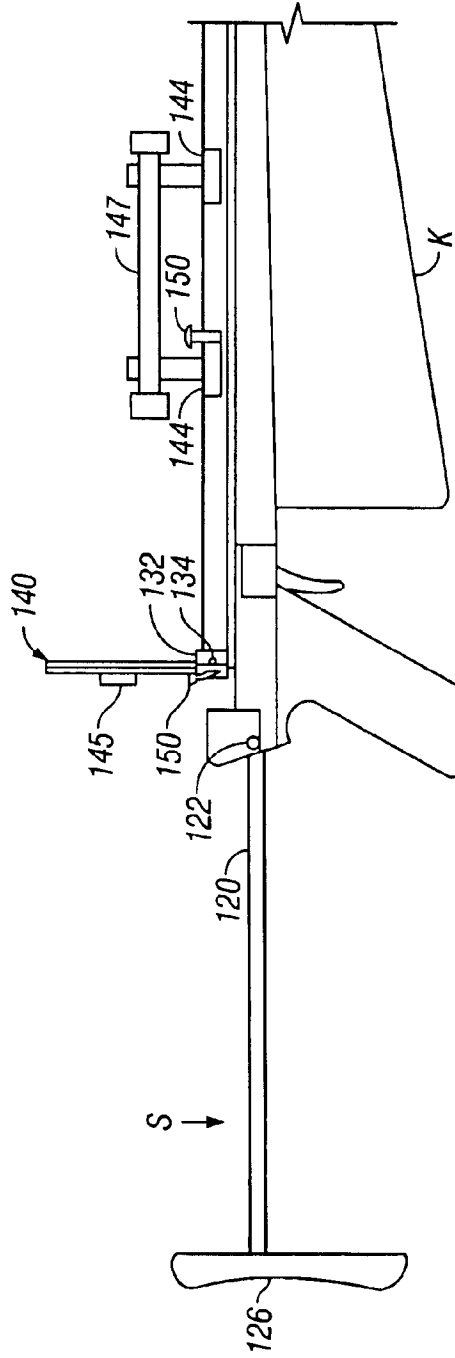

FIG. 14

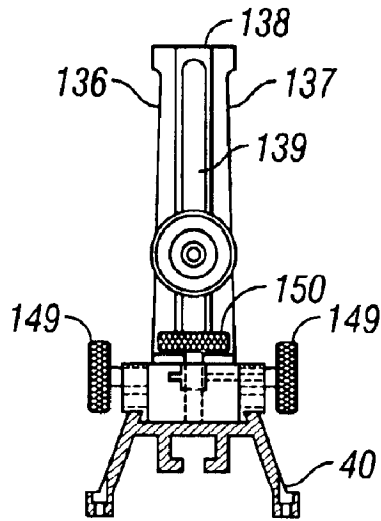

FIG. 15

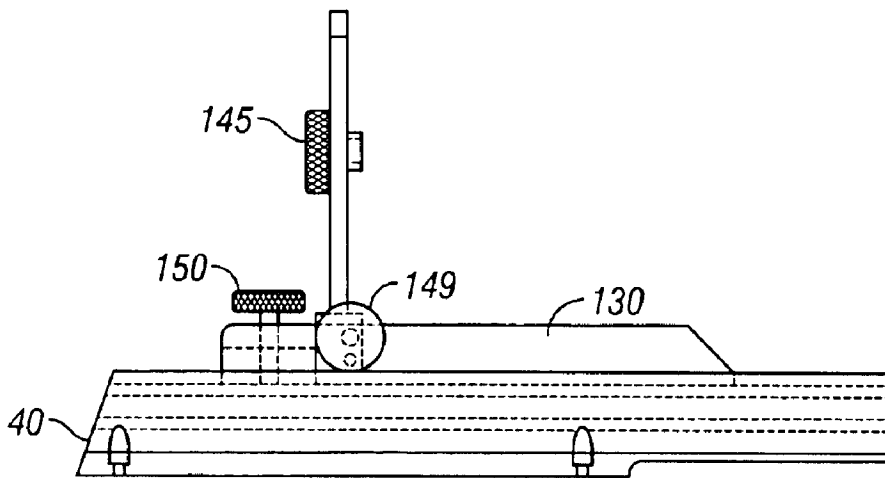

FIG. 15A

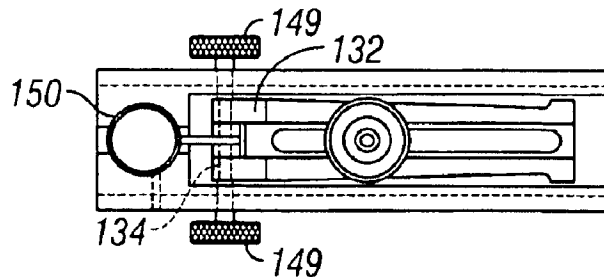

FIG. 15B

1

AUTOMATIC LOADING CROSS-BOW

BACKGROUND OF THE INVENTION

Field of the Invention

The present invention relates to a new and improved cross-bow construction and particularly to an automatic loading cross-bow having a clip or magazine for storing a plurality of arrows or projectiles, an improved internal guiding track for faster and more accurate firing, and an improved outer upper surface of the guiding track for slidably positioning various sights or scopes. The cross-bow of the present invention also includes an improved trigger mechanism and a safety release which preferably prevents unintentional or accidental discharge as well as providing a smooth and accurate intentional discharge.

BRIEF DESCRIPTION OF THE DRAWINGS

FIG. 1 is a side elevation partly in section and partly in phantom illustrating the improved automatic cross-bow apparatus with the arrow clip in position.

FIG. 2 is a top view of the cross-bow illustrating the upper guide and with the bow limbs in the extended position.

FIG. 3 is a bottom view of the cross-bow with the bow limbs folded back in a retracted position.

FIG. 4 is a sectional view illustrating an arrow in the firing position in the cross-bow and the bow string being drawn across the trigger mechanism.

FIG. 5 is a sectional view illustrating the arrow feeding mechanism and a cross section of the upper guide and insert.

FIG. 6 is a view illustrating the mounting of the bow limbs on the main frame of the cross-bow.

FIG. 6A is a side view of FIG. 6 illustrating further details of the mounting of the bow limbs on the main frame of the cross-bow.

FIG. 7 is a sectional view illustrating the arrow clip.

FIG. 8 is a transverse sectional view illustrating additional details of the arrow clip.

FIG. 9 is a view illustrating an embodiment with a rifle stock.

FIG. 10 is a view illustrating the bow string release mechanism.

FIG. 11 is a side elevation partly in section illustrating the bow string release apparatus with the trigger in the cocked position.

FIG. 12 is a side elevation partly in section illustrating the bow string release apparatus with the trigger in the firing position.

FIG. 13 is a top view illustrating the spring plate and the bow spring used in the clip.

FIG. 13A side view of FIG. 13.

FIG. 14 is a side elevation partly in section illustrating the retractable shoulder stock in an extended position with the aiming sight elevated for use.

FIG. 15 is a front view illustrating additional details of the slidable base of the elevated sight.

FIG. 15A is a side view illustrating additional details of the slidable base of the elevated sight.

FIG. 15B is a top view illustrating additional details of the slidable base of the elevated sight.

DESCRIPTION OF EMBODIMENTS

An exemplary type of cross-bow is shown in U.S. Pat. No. 3,739,765, issued Jun. 19, 1973, to Ralph J. Moore, which

2

is incorporated herein by reference. As illustrated in FIGS. 1 and 2, an embodiment of the cross-bow C preferably comprises a main frame F having a pair of bow limbs B pivotally mounted on opposite sides of the main frame adjacent its front end and a shoulder piece or stock S retractably mounted adjacent the rear end of such main frame F. A pistol grip P is also affixed to the rear of the main frame on its lower side and preferably at least partially enveloping a firing mechanism 70, which is provided for holding the bow string E taut when the bow is cocked and for releasing such bow string to discharge an arrow A when the cross-bow is fired. It should be appreciated that the pistol grip can be covered or encased by rubber, plastic, wood, or any other material that is suitable to provide gripping ability as well as add utility or aesthetic value to the grip or the cross bow. An arrow clip K containing a plurality of arrows is releasably attached to the main frame F for automatically feeding an arrow into the main frame for firing each time the bow string E is drawn back and latched in the firing mechanism 70. It should be understood that the arrow clip K can also be called a magazine or otherwise described such as to convey the meaning of one of its functions; that of storing a plurality of arrows A. The plurality of arrows A, being stored in the clip K (FIG. 7), can be target arrows or hunting arrows or a combination of hunting and target arrows. It will be appreciated by those in the art that the clip K can accommodate a variety of hunting arrows including, but not limited to, those having two, three, or four blade arrowheads 17 disposed about the front of the arrow. It will also be appreciated that when utilizing the hunting arrows, the blades, of the arrowhead 17, will remain contained in the clip K or in the firing chamber of the cross bow thus reducing the risk of accidental cuts from the blades when transporting or handling the cross bow.

FIG. 3 illustrates the frame F as preferably comprising a pair of laterally spaced, longitudinally extending side rails 11, 12 which are disposed substantially parallel to each other and are preferably connected together at the front end by the front transverse member 13 and at the rear by the rear transverse member 14. Preferably a centrally disposed, longitudinally extending opening 15 is provided in the main frame F between the side rails 11, 12 to permit arrows A to be moved from the arrow clip K in to the firing position in the firing chamber in the main frame member F.

As best seen in FIGS. 3 and 4, the central opening 15 includes a longitudinally extending slot for receiving the shaft or body 16 of the arrows A with an enlarged or relieved portion 15a for accommodating the arrowhead 17 disposed about the forward end of the shaft 16, and another enlarged or relieved portion 15b to accommodate the vane, feather or rear stabilizers 18 affixed adjacent the rear end of the arrow shaft 116. With the relieved portions 15a, 15b in the centrally disposed opening or passage 15, it will be appreciated that the arrows A may be moved vertically from a storage position in the clip K into position in the main frame F for firing with the longitudinal axis of the arrows A being maintained substantially parallel to the longitudinal axis of the main frame F.

A pair of longitudinally extending jaws or gate members 20, 21 are slidably mounted on top of the side rails 11, 12. The gate members 20, 21 are preferably coated with a TEFLON (tetrafluoroethylene fluorocarbon polymer—TEFLON is a registered trademark of DuPont du Nemours, E.I. & Co.), polyethylene, or similar resilient and substantially self lubricated element. This coating will preferably decrease the resistance or friction of the gate members against the arrow shaft 16 and feathers 18 when the appa-

3

ratus is fired; thus preferably providing a faster and more accurate shot. The gate members can also be polished, coated, anodized, or otherwise treated to form a surface with limited frictional resistance when the arrow A is fired. Such slidable gate members **20**, **21** preferably include forward relieved portions **20a**, **21a** for receiving the arrowhead **17** and rear relieved portions **20b**, **21b** for permitting the feather **18** to pass therethrough without damage when the arrows A are moved from storage in the clip K into the firing position above the jaws **20**, **21**.

The sliding jaws **20**, **21** are provided with longitudinally spaced diagonal guides **20c**, **21c** which preferably extend inwardly and forwardly relative to the central opening **15**. Guide pins or lugs **20d**, **21d** extend through the guide slots **20c**, **21c** and are affixed to the upper surface of the main frame F. Actuating pins **20e**, **21e** project upwardly at the rear end of the sliding jaws **20**, **21** and, as illustrated in FIG. 4, are engaged by the bow string E when it is drawn back and latched in the firing mechanism **70**. As illustrated, when the bow string E is moved rearwardly as indicated by the arrow **30** in FIG. 4, it engages the upstanding pins **20e**, **21e** and moves the sliding jaws **20**, **21** rearwardly and also outwardly due the diagonally disposed guide slots **20c**, **21c** acting against the guide pins **20d**, **21d** to thereby spread the jaws **20**, **21** laterally apart to allow the uppermost arrow A in the main frame F to be moved upwardly between the gates **20**, **21** and into the firing position atop the gates **20**, **21** as will be described in detail herein below.

As illustrated in FIG. 5, the gates **20**, **21** are provided with upwardly and outwardly rounded inner edges **20f**, **21f** which extend axially of the arrow shaft **16** for supporting and aligning the shaft **16** in position for firing. As illustrated in FIG. 4, each of the gates **20**, **21** is preferably provided with a spring **20g**, **21g** which is preferably carried in the recesses **20h**, **21h** disposed in the gates **20**, **21**. The forward end of the springs **20g**, **21g** are connected to pins **20j**, **21j** mounted on the upper side of the main frame F and the rear end of the springs **20g**, **21g** are connected in suitable openings **20k**, **21k** in the gates **20**, **21** adjacent the rear of the recesses **20h**, **21h**. The springs **20g**, **21g** move the gates **20**, **21** from the open position when the bow string E is allowed to move forward against the latching member in the firing mechanism **70**.

Referring now to FIGS. 2 and 5, an upper guide member **40**, which also extends axially of the shaft **16**, is provided for guiding the arrow A which moves when fired. The upper guide **40**, in one embodiment, comprises an inverted substantially U-shaped member having a base **41**, a pair of lower depending sides **42**, **43** extending along the opposite edges of the base **41** and a pair of upper extending sides **42u**, **43u**. As best illustrated in FIG. 5, in one embodiment, the two upper extending sides **42u**, **43u** are preferably angled such that they form a track or channel **41c** capable of retaining slidable elements such as sights or scopes (see FIG. 14). It should be understood that the configuration of the upper portion of the upper guide **40** can vary extensively without departing from the spirit of this invention. For example, but not limited to, the upper extending sides **42u**, **43u** can be configured to form a channel **41c** which is substantially circular, square or rectangular, the sides of the channel **41c** can form a double groove or multiple grooves, it can be configured similar to the lower depending sides **44a**, **44b**, or it can even be configured such that some type of dovetail groove is on the outside of the upper extending sides **42u**, **43u**. One of the primary improvements regarding the upper guide **40** is to retain a guide insert **45** on the underside of the upper guide **40** (see generally FIG. 5) while forming a method of slidably retaining elements such as

4

sights or scopes on the top side of the upper guide **40** (see generally FIGS. 5, 14, 15, 15A and 15B). It is foreseeable, and therefore should also be appreciated by those skilled in the art, that the lower depending sides **44a**, **44b** can be similarly configured to the upper extending sides **42u**, **43u** in order to retain any configuration of an upper guide insert **45**. The track or channel **41c** forms a substantially longitudinal channel that extends substantially the length of the main frame F. Two centrally depending projections **44a**, **44b** extend longitudinally along the base **41** and are positioned above and between the inclined guide surfaces **20f**, **21f** (FIG. 5). The two centrally depending projections **44a**, **44b** preferably have substantially "L" shaped mirror-image cross-sections. An upper guide insert **45**, having a substantially "T" shaped cross section and which extends longitudinally along the base **41**, is attached within the two centrally depending projections **44a**, **44b**. It should be understood that the upper guide can be attached in a large variety of methods including, but not limited to, screws, glueing/bonding, dovetail or other groove configurations. It should further be understood that the cross section of the upper guide insert **45** could vary from the "T" cross section particularly if the method of attachment differs or if the configuration of the lower depending sides **44a**, **44b** vary as described herein above. It should also be noted that if the arrow head **17** is comprised of a four-blade head, the upper guide insert **45** should be shortened such that the insert **45** does not extend forward so as to cover the recesses **64**, **65** which are provided near the forward end of the arrow clip K side walls **50**, **51** (see FIG. 8 and the description herein below). Therefore, the upper guide insert **45** could also be a two-piece insert such as to facilitate the ability to uncover the above described recesses **64**, **65**, as well as uncover previously described relieved portion **15a** whenever a four-blade arrow is used or if some other arrowhead **17** configuration is used which would be obstructed by a one-piece full length upper guide insert **45**. The upper guide insert **45** preferably engages the shaft **16** of the arrow A retaining it on such surfaces when it is being fired or moved therealong by the bow string E. Preferably the upper guide insert **45** is of a material that possesses self lubricating qualities such as UHMW, TEFLON (tetrafluoroethylene fluorocarbon polymer—TEFLON is a registered trademark of DuPont du Nemours, E.I. & Co.), other polymer compounds, other rigid materials, or the like whereby such material preferably decreases the friction between the upper guide insert and the arrow shaft **16**. This decrease in friction preferably provides for a faster and more accurate movement of the arrow shaft **16** through the crossbow barrel or firing chamber thus preferably providing for a faster and more accurate arrow A or projectile after being launched from the crossbow C. It should be appreciated that the upper guide insert **45** will allow for an increased velocity of the arrow A upon firing due to the reduction of friction between the arrow shaft **16** and the guide insert **45**. The additional coating of the gate members **20**, **21**, which serve as a bottom guide for the arrow A, will further reduce the overall frictional forces to preserve the increased velocity and firing accuracy. It should further be appreciated that since the present apparatus fully envelops the arrow A in the firing chamber, i.e. the upper guide insert **45** and the closed gate members **20**, **21**, the cross bow can be accurately fired in substantially every position including upside down.

As best seen in FIG. 5, there are parallel longitudinally extending recesses **46**, **47** formed between the central projections **44a**, **44b** and the depending sides **42**, **43** which provide an unobstructed passageway for the upper feathers

5

18 on the arrow A as it is moved along the surfaces 20f, 21f. Similarly, the lower feather preferably passes through the slot or central opening 15 between the gates 20, 21 and in the main frame F.

As illustrated in FIG. 4, the rear end of the arrow shaft 16 is preferably provided with a pair of parallel faces 16a, 16b which are received in a suitable guide slot 55 (FIGS. 7 and 8) to orient the arrow A with two of the feathers 18 aligned in the openings 46, 47 and with the third feather 18 disposed in the central opening 15.

As illustrated in FIGS. 7 and 8, the clip K which contains a plurality of arrows A comprises a case having laterally spaced apart sides 50, 51 preferably joined together at the forward end by a front transverse member 52 and at the rear end by a rear transverse member 53 with an upwardly and forwardly inclined bottom 54. A vertically disposed groove 55 is preferably provided in the rear end portion 53 for receiving the substantially parallel faces 16a, 16b on the arrow shaft 16 (see FIG. 4) and to serve as a guide for orienting such arrows A with the upper feathers 18 aligned with the spaces 46, 47 formed between the central projections 44a, 44b and the depending sides 42, 43 (see FIG. 5), and the lower feather 18 aligned with the central opening 15 (FIG. 3).

As illustrated, the spaced apart walls 50, 51 provide a central recess 60 (FIG. 5) for receiving the arrow shafts 16. Recesses 61, 62 are provided near the rear of the walls 50, 51 to accommodate the feathers 18 on the arrow shaft 16 so as to enable such arrows to be stored in the clip K without the feathers 18 being bent or crushed and to also facilitate movement of the arrows A vertically as they are discharged from the clip K as will be described hereinafter. Also, recesses 64, 65 are preferably provided near the forward end of the walls 50, 51 to provide space for the arrow heads 17. As best seen in FIG. 7, a suitable spring 66 is secured to the bottom 54, of the clip K, for urging the arrows A vertically so as to move them from the clip K into the main frame F. The improved spring 66 is preferably attached to the spring plate 67. The method of attaching the spring 66 to the spring plate 67 is preferably by screws 68. However, it should be appreciated that any variety of attachment methods such as welding, tack or spot welding, rivets, bolt and nut, glueing, and the like can be used. The spring plate 67 is preferably of a substantially "H" shaped configuration with a bow strip 69 disposed longitudinally or substantially parallel to the arrow shaft 16 along the upper side of the "H" shaped configuration (See FIGS. 13 and 13A). The bow strip 69 is substantially restrained when more than one arrow A is in the magazine K. When the final arrow A is ready for loading into the firing chamber, the bow strip 69 preferably becomes unrestrained and is configured to spring upwardly with a substantially convex surface then pushing on the arrow shaft 16. This upwardly convex surface urges the final arrow A into the firing chamber. As illustrated in FIG. 8, pins 66a are preferably inserted in the clip K to prevent the spring plate 67, and thus the spring 66, from being inadvertently dislodged from the clip K, particularly when clip K is empty and is removed for reloading. It should be appreciated that the spring retaining pins 66a can be any type of retention device such as buttons, button latches, crimped edges, and the like.

As further illustrated in FIG. 7, the feathers 18 are further protected from damage, such a collapse or disfigurement, especially during storage preferably by the inclusion of a spacer ball 75 between each of the arrow shafts 16. The spacer ball 75 is preferably metallic but can be any material which can resist deformation by the arrow shaft 16. Such

6

materials could include, but are not limited to, plastic, polymer, methyl acrylate, or rubber. It should be appreciated that the ball 75 can also be a variety of shapes including but not limited to a pill, a box, a plug, any tapered pins or plugs, and the like. The ball 75 maintains a substantially vertical space between the arrows A being stored in the clip K. When the arrow A is being loaded from the clip K into the firing chamber, as is described herein, the ball 75 is preferably expelled through a hole 6 which preferably passes through the upper track 40 (see FIG. 2) and the upper guide insert 45 (see FIG. 5).

Referring again to FIG. 8, the clip K is preferably secured to the main frame F by the insertion of the tongue 5 into a corresponding groove in the forward portion of the main frame F as to some extent illustrated in FIG. 1. Further, button latches 57, located to the rear of the clip K (FIG. 8) engage the main frame F. Thus, the clip K is preferably snapped into place and securably attached to the main frame F until manually removed. It should be apparent to those skilled in the art that this attachment can be varied without departing from the spirit of the invention by using other available fastening means such as pins, grooves or notches in the frame, quick connects, and the like.

As illustrated in FIGS. 10-12, an improved firing mechanism 70 has a substantially "U" shaped cavity in the front end. The mechanism 70 preferably has three closed sides with the front, top, and bottom sides open. The two lateral sides 71, 72 preferably have a pair of pins 73 inserted through suitable holes 73a in the two lateral sides 71, 72. The pins 73 preferably act as a string release stop pin to prevent damage or overtravel of the latch 77. It should be appreciated that the stop pins 73 can be a single pin or two pins as described herein. It should further be appreciated that the material of the pins can also vary and is not intended to be limited to a metallic material. The firing mechanism 70 preferably slidably fits, at least partially, into the pistol grip P. This allows for greater ease in handling the cross bow for firing. The slidable fit of the firing mechanism within the pistol grip provides for fast installation and assembly or disassembly. The slidable fit can be accomplished through the use of grooved, dove-tailed, or similar channels and is preferably provided with a quick lock feature such as retractable pins, screws, thumb screws, latches, buttons, or the like.

A bow string latch 77 is positioned between the two lateral sides 71, 72 and is pivotally mounted on a pin 77a extending through suitable openings in the two lateral sides 71, 72. The bow string latch 77, which is illustrated in FIGS. 10 and 11, preferably comprises a body having a pair of laterally spaced upstanding projections 81, 82 with a groove 83 therebetween for receiving the bow string E. When the string E is released by pivoting the latch 77 forwardly, string E engages the rear end of the arrow shaft 16 and drives such shaft forward to fire it. It should be appreciated that in order to preferably have precise and accurate firing of the arrow A, the upstanding protrusions 81, 82 of the latch 77 should be substantially smooth. Preferably, the smooth surface will substantially remain in contact with the string as the string is released and moves in a substantially longitudinal and frontward direction. Preferably, this contact will prevent the string from jumping or moving in a non-longitudinal direction which could prevent a true center line firing.

As illustrated in FIGS. 11 and 12, the bottom 80 of the bow string latch 77 is provided with a concave cam surface 90 which is of substantially the same radius as the cylindrically shaped cam surface 91 on the cylindrical trigger support 92. A return spring 94 connects the bottom of the

bow string latch body **77** with a pin or rod **95** that is carried in the rear of two lateral sides **71** and **72** and extends transversely therebetween.

The trigger **100** is illustrated in FIGS. **11** and **12**. The trigger **100** is preferably integral with the cylindrical trigger support **92**. It must be appreciated that the trigger **100** and the cylindrical trigger support **92** can be separate pieces attached by a suitable means. The trigger **100** is rotatably mounted on a transversely extending pin or rod **104** that is also mounted in suitable openings in the two lateral sides **71** and **72**. The front portion of the cylindrical trigger support **92** is provided with a transversely extending groove designated generally **105** that has a base **106** and a pair of parallel sides **107** and **108**. A spring **96** is preferably attached between a hole **85** in one of the parallel faces **107** of the groove **105** in the cylindrical trigger support **92** and the string release stop pin **97** to provide for returning the trigger **100** and the cylindrical trigger support **92** to its original pre-firing position. It should be appreciated the attachment of the spring **96** in a hole **85** is a preferred embodiment; however, a varied place of attachment to the cylindrical trigger support **92** is still within the spirit of the present improvement.

The cylindrical trigger support **92** is preferably relieved on the opposite side from the groove **105**. The cylinder is cutaway or relieved so as to permit the bow string latch **77** to pivot forward and release the bow string **E** when the trigger support cylinder **92** is rotated in the direction of arrow **78** from the position illustrated in FIG. **11** to the position illustrated in FIG. **12** of the drawings.

As illustrated in FIGS. **10–12**, the improved firing mechanism **70** is preferably more efficient and smaller. The compact firing mechanism **70** preferably allows closer proximity between the string **E** and the arrow **A** thus preferably providing a more positive strike action, when the string **E** is released. The firing mechanism **70** is preferably retained in the main frame **F** by the housing mounting pin **109**. It should be appreciated that the firing mechanism **70** can be retained in the main frame **K** in any suitable manner including, but not limited to, screws, set screws, bolts, various pins, and the like. It should further be appreciated that the firing mechanism **70** could be more permanently attached within the main frame **F** if desired. The firing mechanism **70** preferably includes a trigger safety latch **112** which is connected to a shaft **110** carried in the two lateral sides **71**, **72**. The safety latch **112** includes a half cylinder **115** which is rotatably mounted between the two lateral sides **71**, **72** on the shaft **110**. The half cylinder **115** has a convex curved surface **116** which terminates in a plane surface **117**. The safety **112** locks the trigger support cylinder **92** against rotation in the direction of arrow **78** as long as the convex curved surface **116** engages the plane surface **93** on the back of the trigger support cylinder **92**. As the shaft **110** is rotated, the half cylinder **115** preferably turns from the position illustrated in FIG. **11** to the position illustrated in FIG. **12**, and the curved surface **116** on the half cylinder safety block **115** is moved out of contact with the plane surface **93** on the back of the trigger support cylinder **92**, thereby permitting such trigger to be rotated rearwardly as indicated by the arrow **79**. Such movement of the trigger preferably rotates the trigger support cylinder in the direction of arrow **78** and the convex cam **91** is moved out of engagement with the concave cam **90** on the base of the bow string release block **77**, freeing such block to rotate or pivot forwardly to thereby release the bow string **E** so as to fire the arrow **A** from the cross-bow **C**. A spring **86** preferably connected between the half cylinder safety block **115** and a pin **111** on the rear side of the firing

mechanism **70** is preferably biased to return the half cylinder **115** to the position illustrated in FIG. **11**.

FIG. **14** shows the improved shoulder rest or stock portion **S** of the cross-bow **C** in extended position for firing. The shoulder support or shoulder stock **S** comprises a pair of laterally spaced arms **120** which are preferably slidably mounted at the rear of the main frame **F**. The substantially longitudinal extension of the arms **120** can preferably be releasably adjusted in a multitude of positions providing a variety of lengths between a substantially fully extended position and a substantially fully retracted position. The intermediate longitudinal positions can be releasably fixed through a pair of adjustment screws **122**, through a series of notches or grooves disposed along the length of the arms **120** and corresponding receiving notches or grooves at the rear of the main frame **F**, or with an adjusting slot preferably cut substantially the length of the arms **120**. The outer ends of the arms **120** are preferably fixedly attached by the pad or shoulder rest **126**. It should be appreciated that although a variety of attachment methods are available, the preferred method of attachment is screws or other fasteners that can be relatively easily detached for cleaning, compact storage, and transportation of the apparatus.

In another embodiment, a rifle stock **10** can be attached to the rear of the main frame **F** (FIG. **9**). In this embodiment, the extendible stock **S** can either be removed or it can remain in its retracted position. As illustrated, the rifle stock is integral with the pistol grip **P1** and therefore is releasably attached in place of the pistol grip **P**.

An adjustable peep sight **140** (FIGS. **14**, **15**, **15A**, and **15B**) is preferably provided on the cross bow **C**. The peep sight **140** preferably includes a sub base **130** which is “U” shaped to protect the peep sight **140** when it is in the lowered or closed position. The peep sight **140** further comprises a base portion **132** which is mounted on a pivot pin **134**, and includes a pair of upstanding arms **136**, **137** which are preferably spaced laterally apart and attached together at their lower ends at the base **132** and their upper ends by transverse member **138**. A substantially longitudinally extending slot **139** is thus formed between the upstanding arms **136** and **137** for receiving a movable sight member **145**. The movable sight member **145** may be moved upwardly or downwardly on the upstanding arms **136**, **137**.

The improved adjustable peep sight sub base **130** is slidably attached between the upper extending sides **42u**, **43u**. Thus, allowing for the adjustable peep sight assembly to be moved longitudinally along the upper guide member **40** through the channel **41c** formed between the upper extending sides **42u**, **43u**. It should be appreciated that the rear adjustable peep sight can be removed when using a scope, described further herein below, or can remain attached to the upper guide **40** but in its lowered position.

When the rear adjustable peep sight **140** is used, preferably lock screws **149** are mounted in the sub base **130** on opposite sides of the upper extending sides **42u**, **43u** so as to engage the base block **132** and lock it in a desired position. It should be appreciated that the lock screws **149** are positioned such as to provide alternate positions of affixing the rear peep sight **140**. A preferred method of such attachment is for the lock screws **150** to thread through the sub base block **130** into the substantially longitudinal channel **41c**. Alternative attachment methods can include, but are not limited to, having a substantially longitudinal slot in the upper extending sides **42u**, **43u**, several threaded holes on each of the upper extending sides **42u**, **43u**, or various other methods of adjustable positioning. A spring is connected to

the pivotally mounted base block **132** for swinging the arms **136, 137** into a vertically upright position as illustrated in FIGS. **14, 15,** and **15A**. The lock screws **149** may then be tightened to hold the peep sight in its erect position for firing. When it is desired to retract the peep sight, the lock screws **149** may be loosened and the peep sight lowered and thereafter the lock screws **149** may again be tightened to lock the peep sight in its retracted position. The lock screws are also preferably used to adjust the windage from right to left and vice versa.

The improved upper guide member **40** also provides for the attachment of a scope **147**. The scope **147** can comprise a quick locking scope mount with a completely adjustable eye relief. As illustrated in FIG. **14**, the scope **147** is removably attached to a base **144**. As with the improved adjustable rear peep sight **140**, the scope base **144** is slidably mounted within upper extending sides **42u, 43u**. The scope bases **144** are preferably attached in the manner described for the rear peep sight sub base **130** described herein above. A front peep sight **8** (FIG. **1**) is similarly mounted at the front of the upper guide **40** and is also removable and slidable along the channel **41c** formed on the top of the upper guide **40**. As previously described herein above, the various configurations of the channel **41c** can be adapted to a variety of front sights. Therefore, it should be appreciated that the selection of different front or rear sights or scopes will not depart from the spirit of this invention. It should be further appreciated that any sights, scopes, and the like can be attached with a quick locking mechanism to facilitate quick attachment and removal.

The bow limbs **B** are preferably pivotally mounted near the forward end of the main frame **F** to permit the bow limbs **B** to be pivoted from the retracted position as illustrated in FIG. **3** of the drawing outwardly into the extended position illustrated in FIG. **2** for firing. The string **E** is preferably attached such that when in the cocked position, the string **E** substantially extends in the same plane that passes through the center of the bow limbs **B** when they are in the extended position; such plane is substantially parallel to the main frame **F**.

As illustrated in FIGS. **2, 6,** and **6A**, the bow limbs **B** are attached to mounting blocks **160** which are pivotally connected by pivot pins **162** to the connecting blocks or the pivot blocks **163** that are integrally formed near the forward end of the main frame **F**. It is understood that the pivot blocks **163** can also be separate from the main frame **F** and attached to the main frame **F** by screws (not shown) or other suitable fasteners. Spring loaded latching pins **165** are carried on the bow blocks **160** and are adapted to be inserted into the openings **167** in the pivot blocks **163** when aligned therewith.

As illustrated in FIGS. **6** and **6A**, the bow block **160** is preferably provided with a pair of laterally projecting plates **160a, 160b**. The plates **160a, 160b** form an opening **168** between them and can be parallel to each other although in a preferred embodiment they are preferably angled inwardly toward each other. The angled opening preferably comprises inclined surfaces **170, 171** provided on opposite sides of a base **173** disposed at the bottom or back of the opening. Suitable openings **175, 176** are provided through the plates **160a, 160b**, for receiving the latching pins **165**. Preferably there will be at least one latching pin **165** passing through each of the openings **175, 176** on each of the bow blocks **160**. Each of the pins **165** is connected to a spring loaded thumb latch **180** which can be depressed causing the pins **165** to disengage. Springs **188** urge the thumb latch **180** to push the latching pins **165** through the openings **175, 176** in the laterally projecting plates **160a, 160b**.

The connecting block or pivot block **163** is preferably provided with a converging tapered or inclined surfaces **190, 191** which form a wedge-like portion that is adapted to be received between the laterally projecting plates **160a, 160b** of the pivot blocks **160**. An opening **167** is provided in the wedge-shaped portion of the connecting block or pivot block **163** and extends through to the inclined surfaces **190, 191** and is provided for receiving the ends of the latching pins **165** that are slidably mounted in the laterally spaced openings **175, 176** on opposite sides of the laterally projecting plates **160a, 160b**.

If desired the bow blocks **160** may be swung in position and the wedge shaped surfaces **190** and **191** will engage the pins **165** to force them laterally apart and permit the bow block **160** to be pivoted over the connecting block or pivot block **163**. When the pins **165** become aligned with the openings **167** in the wedge shaped portion of the connecting or pivot block **163**, the pins **165** will move laterally to engage the openings **167** and thus lock or latch the ends of the bow in the extended position such as is illustrated in FIG. **2**.

In order to release the latching members and permit the bow block **160** to be swung back to the retracted position such as illustrated in FIG. **3**, the thumb latch **180** is depressed causing the pins **165** to withdraw from the openings **167** in the pivot blocks **163**. When the bow limbs **B** and the bow block **160** are completely retracted, they will be held in the retracted position preferably by a small ball latch or button latch **192**. It should be appreciated that the function of such a ball latch or button latch **192** is to merely keep the bow limbs **B** from extending while the cross bow is being transported or handled. However, preferably any latch which retains the bow limbs **B** in the retracted position must be easily overcome when moving the bow limbs into the firing position (FIG. **2**).

It will be appreciated, by those in the art, that the quick connect type of latching mechanism provided with the pins **165** acting against the inclined surfaces **190** and **191** will facilitate stringing the bows or bow limbs **B** as it will be necessary to only momentarily position the pins **165** opposite the holes **167** to enable the spring loaded pins **165** to be moved laterally into such openings **167** and thereby locking the bow limbs **B** in their open or extended position suitable for firing.

In another embodiment, bow blocks **160** are adapted to attachably receive a bow limb adaptor plate **184**. This adaptor plate **184**, is preferably fixedly attached to an alternative set of bow limbs. In this manner, various weights of bow limbs can be interchanged to provide a greater variety of performance and utility. Thus, lower weight bow limbs can be attached to the improved crossbow **C** when sufficient power is not available to cock a string attached to heavier weight bow limbs or when different weight limbs are desired for different types of shooting such as target shooting or hunting. Thus, the improved bow hinge latch mechanism is more efficient in that the bow blocks **160** are preferably able to receive substantially any two-piece take down bow through the utilization of the adaptor plate **184**.

Preferably, as illustrated in FIGS. **1** and **3**, a detachable and pivotable stirrup **200** is provided to be releasably and pivotably attached at either the forward end or the rearward end of the main frame **F**. The stirrup can facilitate carrying the cross bow **C**, facilitate loading or cocking the bow, and stringing the bow string **E**. Preferably, the stirrup **200** is attached to the rearward end of the main frame **F** when it is desired to swing the bow limbs **B** into the extended position.

11

In this position, the archer may place one foot in the stirrup **200** to facilitate forcing the bow limbs B in position in their respective bow hinge latch mechanisms to thereby string the bow B. It will be appreciated that the ends of the bow strings E will be affixed to the opposite ends of the bow limbs B prior to the pivotally mounted bow limb hinges being swung into the open or extended position to draw such bow strings taut.

Preferably, when cocking the cross bow C, the stirrup **200** is attached to the forward end of the main frame F. Preferably, the archer may then place one foot in the stirrup **200** at the front end of the main frame and thereby free both hands for use in drawing the bow string E taut and latching it in the trigger mechanism **70** for firing.

In either the forward or rearward position, the stirrup **200** is mounted on a pivot pin **201** which extends transversely of the front and rear ends of the main frame F. With the stirrup **200** attached at either the front end or the rear end, the bow may be carried by simply manually gripping the cross piece of the stirrup **200**. Preferably, the bow limbs B are in the collapsed position, as illustrated in FIG. 3 when the device is carried by the stirrup. It should be appreciated that although the embodiment describes an interchangeable stirrup **200**, the improved cross bow can be provided with two stirrups, one at each the forward end and the rearward end with one or both stirrups **200** releasably attached or with one or both stirrups **200** more permanently attached.

In use the bow limbs B may be secured in suitable openings **160c** in the bow blocks **160** and the bow string E secured to the opposite ends of such bow limbs. Thereafter, the bow limbs B may be pivoted from the retracted position illustrated in FIG. 3 to the extended position illustrated in FIG. 2 to thereby draw the bow string E taut and place the bow limbs B in the position for firing of a cross-bow C. It will be further appreciated that when the bow blocks **160** have been moved to the extended position the locking pins **165** carried therein will be lodged in the openings **167** of the connecting or pivot blocks **163** to thereby securely lock the bow limbs B in their extended position.

With the clip K latched in position in the main frame F and the arrows A stored in the clip K in position under the jaws **20, 21**, the cross-bow is ready for loading and cocking. When the bow string E is drawn back past the firing mechanism **70**, the bow string E preferably engages and pushes back the upstanding pins **20e, 21e** to spread apart the gates or jaws **20, 21** to thereby permit the uppermost arrow A, in the clip K to be urged upwardly by the spring **66** until the arrow engages the upper guide insert **45** that is disposed above the central opening **15** through which such arrow passes. When the bow string E is set against the latch **77**, the jaws **20, 21** will be closed by springs **20g, 21g** and the upper rounded surfaces will thereafter support the arrow shaft **16** in the firing chamber in position for firing. After the safety release **112** has been moved to position for firing, the trigger **100** can be actuated to fire the arrow, and after firing the arrow A, the cross-bow is then ready for the reloading of the next arrow in the clip K. When the bow string E is pulled back to cock the bow and is drawn back past the firing mechanism **70** and engages and pushes back the upstanding pins **20e, 21e** to spread apart the gates or jaws **20, 21**, and releasably mounted on the latch **77**, the gates **20, 21** will again be opened to permit the next uppermost arrow A to be moved upwardly through the opening **15** in the main frame F and to preferably position arrow A in the firing chamber for firing. Thereafter, firing may be repeated until the supply of arrows in the clip K has been depleted. When the last arrow A is ready to be moved through the main frame F

12

opening **15** and into the firing chamber, bow strip **69** (FIGS. **13** and **13A**) will urge the final arrow A into firing chamber.

The foregoing disclosures and descriptions of the apparatus disclosed herein are illustrative and explanatory thereof, and various changes in the size, shape, and materials as well as in the details of the illustrated construction may be made without departing from the spirit of the invention.

What is claimed is:

1. An automatic loading cross bow comprising:

a main frame having a front end and a rear end;

at least two bow limbs mounted on said main frame for firing arrows therefrom along a firing axis;

a clip releasably attached to said main frame for storing a plurality of arrows therein;

a spring plate disposed in said clip for discharging arrows thereon;

a pair of laterally spaced jaws slidably mounted on said main frame wherein said jaws open when the cross bow is cocked to permit an arrow to be urged by said spring plate from storage in said clip into a firing position, in which said arrow is supported by said spaced jaws;

first releasably attached stirrup; and

a retractable stock slidably attached into the rear end of said main frame.

2. The cross bow of claim 1, wherein said plurality of arrows further comprises at least one hunting arrow having at least two blades.

3. The cross bow of claim 1, wherein said plurality of arrows further comprises at least one hunting arrow with more than two blades.

4. The cross bow of claim 1, wherein said plurality of arrows further comprises hunting arrows and target arrows.

5. The cross bow of claim 1, wherein at least one spacer is inserted between each of the said plurality of arrows.

6. The cross bow of claim 5, wherein said at least one spacer is a metallic.

7. The cross bow of claim 5, wherein said at least one spacer is a non-metallic.

8. The cross bow of claim 5, wherein said at least one spacer is ejected through an upper guide when said cross bow is being cocked.

9. The cross bow in claim 1, wherein the said spaced jaws are coated with a non elastomeric coating.

10. The cross bow of claim 1, wherein said first stirrup is releasably and pivotably attached to the front end of said main frame and a second stirrup is releasably and pivotably attached to the rear end of said main frame.

11. The cross bow of claim 1, further comprising a pistol grip substantially encompassing a trigger mechanism, said pistol grip depending downward from said main frame.

12. The cross-bow of claim 11, wherein said pistol grip further comprises a rubber coating for gripping.

13. The cross bow of claim 1, wherein said cross bow can be rotated to any position when firing said arrows.

14. A cross bow comprising:

an upper guide track having an outside and an inside;

said upper guide track having a top side on said outside;

a slidably mounted rear peep sight; and

a slidably mounted scope.

15. The cross bow of claim 14, wherein said upper guide track further comprises a track insert attached to said inside.

16. The cross bow of claim 15, wherein said track insert is of a non-elastomeric and non-metallic material and wherein said track insert guides said arrow when said arrow is fired.

13

17. An improved automatic cross bow comprising:
a main frame having a front end and a rear end;
an extendable stock retractably attached to said rear end;
at least two bow limbs mounted on said main frame for firing arrows therefrom along a firing axis, wherein said
at least two bow limbs are of a specified bow weight
and wherein said at least two bow limbs are inter-
changeable with bow limbs of a different specified bow weight;
an upper guide track having an outside and an inside,
wherein said upper guide having a top side on said
outside and wherein a removable slidably mounted rear
peep sight is slidably attached on said top side, and

14

further wherein a removable slidably mounted scope is
slidably mounted on said top side; and
a clip releasably attached to said main frame for storing a
plurality of arrows therein, wherein a spring plate is
disposed in said clip for discharging arrows thereon,
and wherein a pair of laterally spaced jaws slidably
mounted on said main frame open when the cross bow
is cocked to permit one of said plurality of arrows to be
urged by said spring plate from storage in said clip into
a firing position, wherein said arrow is supported by
said spaced jaws.

* * * * *