

Turned to fit Straight valve body.
 Assemble with silver solder for steam use or
 Soft solder or Loctite for compressed air.

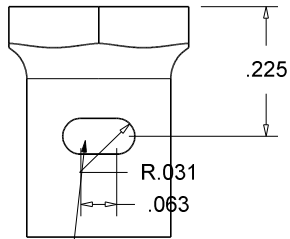

Milled with 1/16" endbill

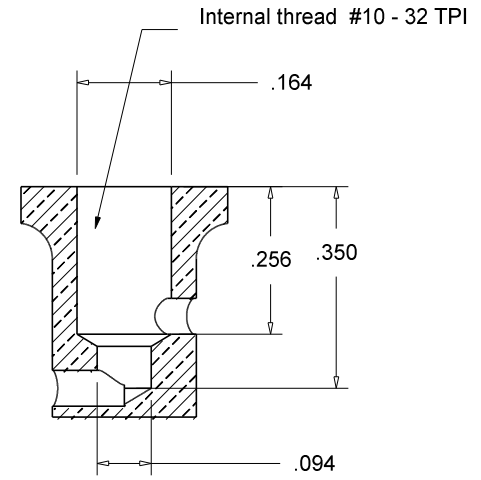
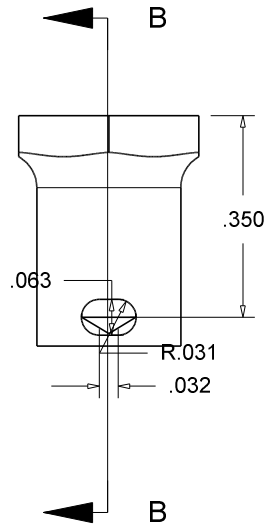
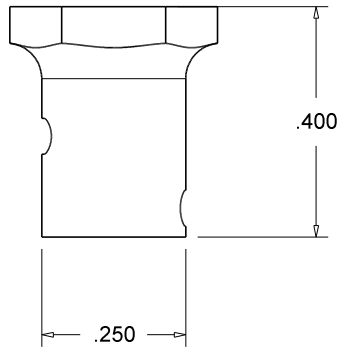

Section B-B

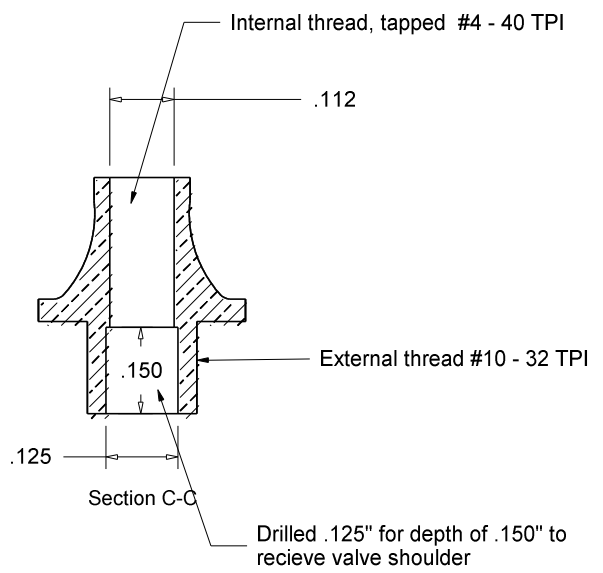
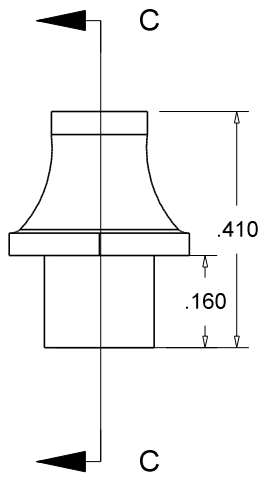
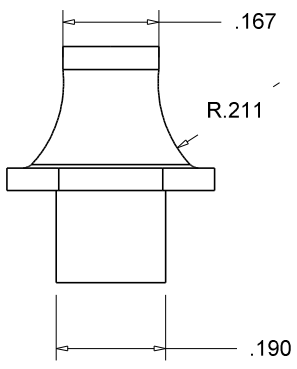
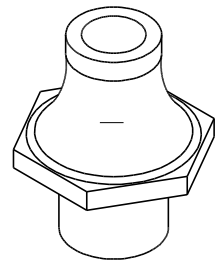
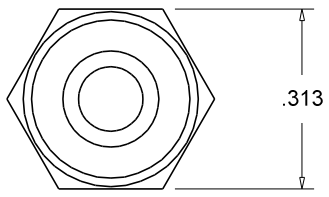

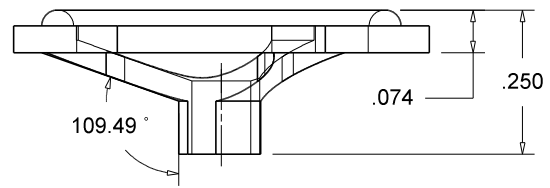
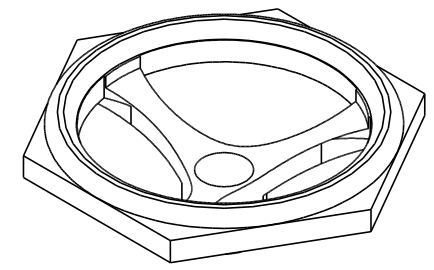
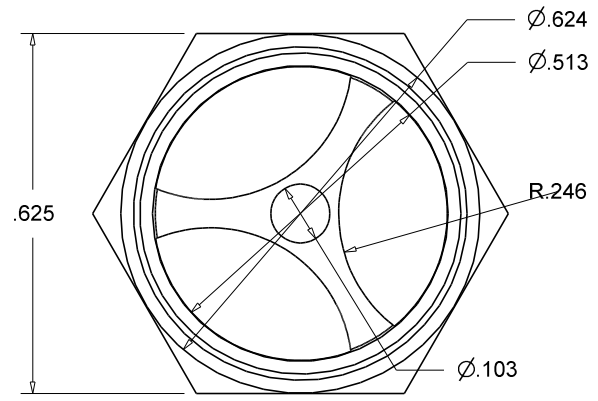
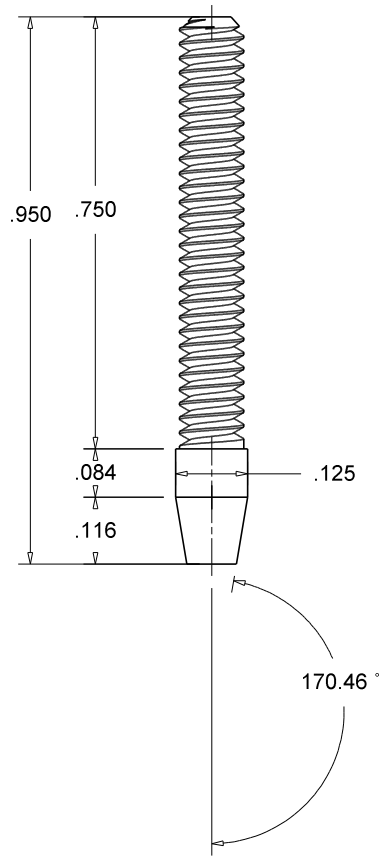

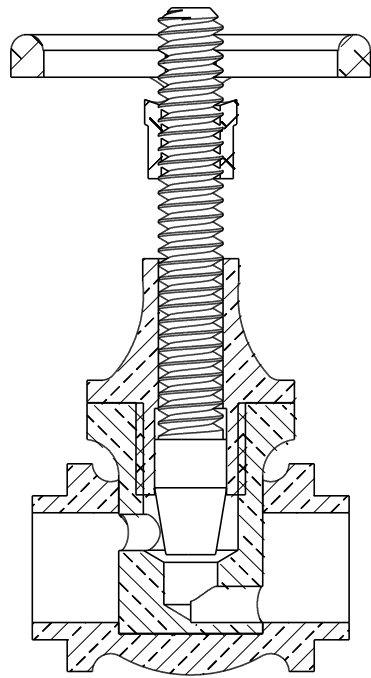
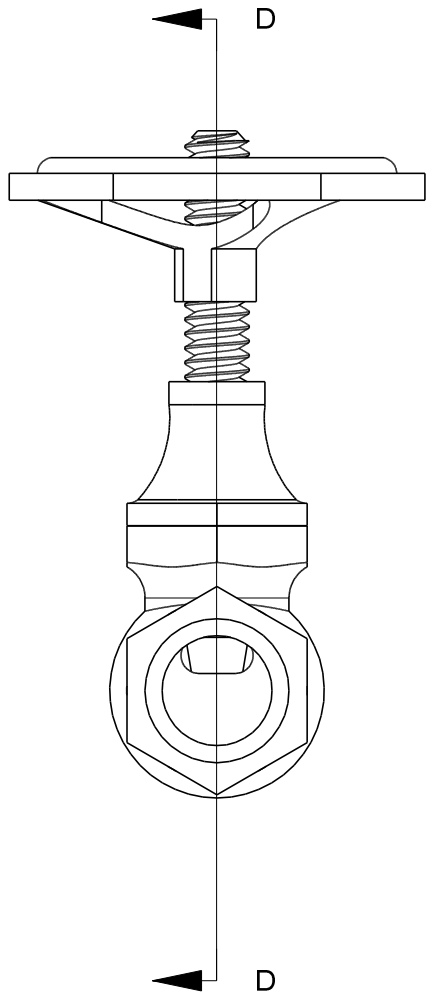
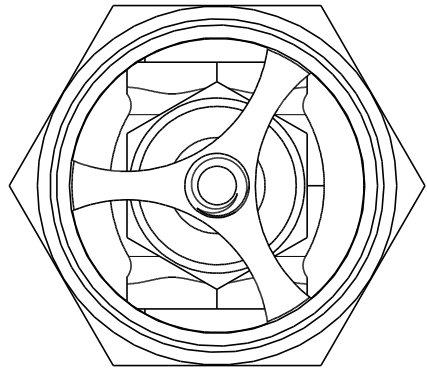

Section D-D

