

Crank
locked in
this position
and drilled

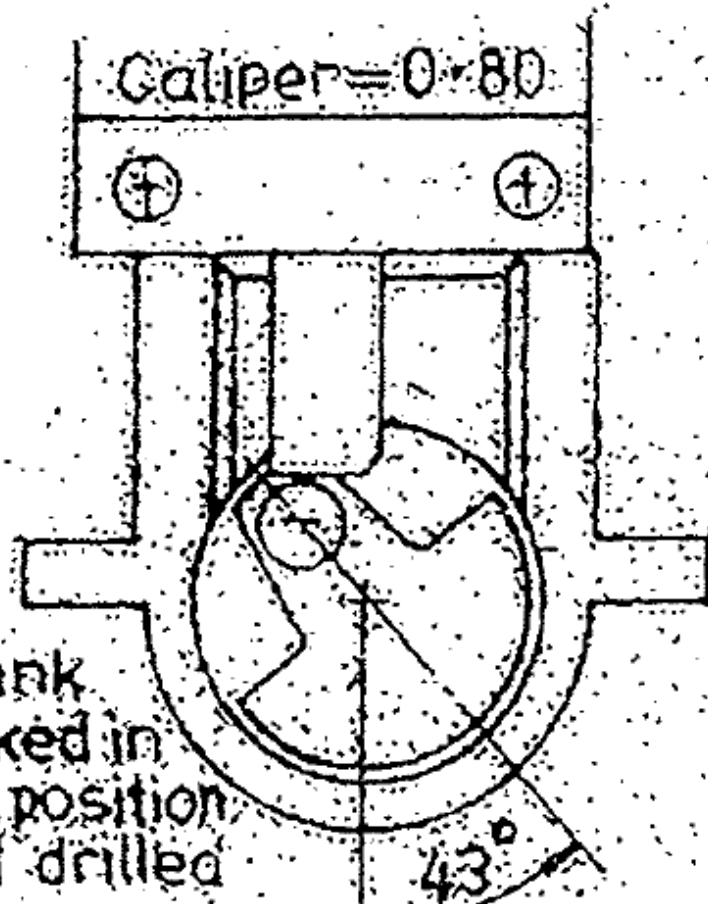

Anticlockwise

Diagram to show how intake
port is drilled in crank at
exactly 43° (not to scale)

