

My Single Axis DRO

On my 1910 Drummond lathe there is a lot of backlash in the cross-slide. This is my attempt at a simple and cheap DRO for it.

After a lot of research online I decided as I had most of the parts, and a bit of knowledge of Arduino processor programming that would be favourite. For the scale I have used a set of cheap digital callipers. You could just bolt callipers to the lathe and use them as is but I wanted a remote screen that I could see without being a contortionist!!

Most callipers come with an opening to connect a data cable to them, it is very difficult to source the correct sort of plug though. I therefore dismantled the callipers and soldered a 4 core wire direct to socket connection pads. Every set of callipers that I have looked at so far have the same connection layout but I would suggest that you look online, there are several articles about using callipers for DRO that explain how to check wiring connections. (see references)

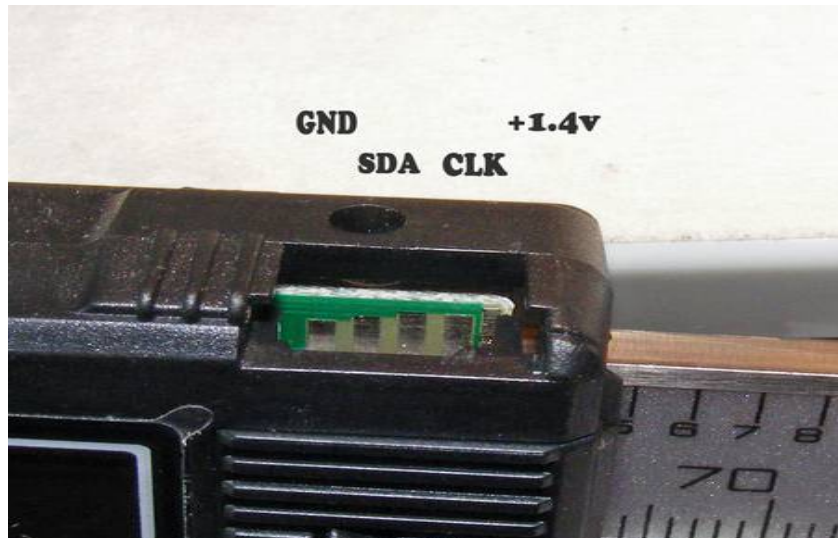

This picture shows the data socket with little cover removed and connections as they are on my calliper.

To dismantle these callipers if you peel the metallised label off the back you will find 4 screws. Remove them but check that they are all the same thread for when you refit them. Apparently some callipers have one oddball screw fitted!! Carefully remove plastic unit from metal callipers. The PCB (printed circuit board) is held in place with 4 more very tiny screws remove them. Mark where screws come from ready for reassembly. Carefully remove PCB you will now have access to the four pads to connect data/power cable too. Have fun soldering,, it is a bit fine but some electronic and machining parts are finer??? I soldered and then hooked cable around the original battery terminal also hot glued as added strain relief on cable. You will have to remove some plastic from between battery compartment to cable compartment to do this.

Now is a good time to make any alterations needed on the metalwork ready to mount on your lathe/mill.

Reassemble in reverse order. Be very careful with PCB positioning as it is only connected to its screen by touch fit..

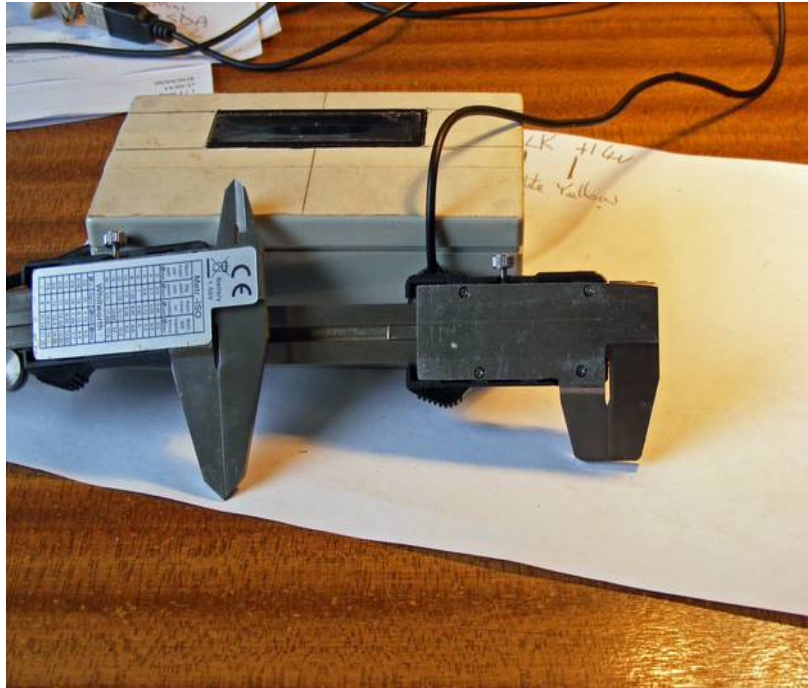

Original calliper on left,,, modified on right to fit onto my lathe, also you can see the screws that are hidden behind the metallised label...



This is the finished calliper. The calliper is now powered from the remote screen box with no need for a battery. Most of these callipers carry on running after you have switched the on/off button to off. All this button does is turn the screen off, so it is a good idea to remove battery on your callipers when they are not going to be used.

Now to the electronics, I have used an Arduino Pro Mini as they are small, cheap and well capable to run this project with room for future expansion, 2 axis, tachometer, etc. Again after internet research I found several Arduino sketches (programmes) but either they wouldn't work or didn't do what I wanted so I ended up with my own. Some of this sketch is copied straight off some published ones with my additions and alterations. The screen will show metric and imperial measurement at the same time so it should suit people on either side of the pond. I could not get remote zero to work

so still need to zero at calliper. I am still looking into this and will amend if I can sort it easily.

Arduino Sketch

```
// My attempt at a single axis DRO for my antique lathe using cheap chinese digital calliper.  
// Processor is 5v Arduino Pro Mini with an I2C 16x2 LCD screen. (screen SDA to A4, SCL to A5)  
//John Collingwood in Wesley's Shed, April 2018  
// Basic programme came off a forum on the internet and then adapted and altered to suit me.
```

```
#include <Wire.h> // Comes with Arduino IDE  
#include <LiquidCrystal_I2C.h>  
LiquidCrystal_I2C lcd(0x3F, 2, 1, 0, 4, 5, 6, 7, 3, POSITIVE); // Set the LCD I2C address  
int i;
```

```
int sign;
```

```
long value;
```

```
float result;
```

```
int clockpin = 4;
```

```
int datapin = 5;
```

```
unsigned long tempmicros;
```

```
void setup() {
```

```
    Serial.begin(9600);
```

```
    lcd.begin(16,2); // initialize the lcd for 16 chars 2 lines, turn on backlight
```

```
// ----- Quick 3 blinks of backlight -----
```

```
for(int i = 0; i < 3; i++)
```

```
{  
    lcd.backlight();
```

```
    delay(250);
```

```
    lcd.noBacklight();
```

```
    delay(250);
```

```
}
```

```
lcd.backlight(); // finish with backlight on
```

```

//----- Write characters on the display -----
// NOTE: Cursor Position: (CHAR, LINE) start at 0
  lcd.setCursor(0,0); //Start at character 4 on line 0
  lcd.print("1910 Drummond");
  delay(1000);
  lcd.setCursor(0,1);
  lcd.print("Split Bed Lathe");
  delay(2000);

// Wait and then tell user they can start the Serial Monitor and type in characters to
// Display. (Set Serial Monitor option to "No Line Ending")
  lcd.clear();
  lcd.setCursor(0,0); //Start at character 0 on line 0
  lcd.print("Single Axis");
  lcd.setCursor(0,1);
  lcd.print("DRO");

  pinMode(clockpin, INPUT);

  pinMode(datapin, INPUT);
}

void loop () {

  while (digitalRead(clockpin)==HIGH) {} //if clock is LOW wait until it turns to HIGH

  tempmicros=micros();

  while (digitalRead(clockpin)==LOW) {} //wait for the end of the HIGH pulse

  if ((micros()-tempmicros)>500) { //if the HIGH pulse was longer than 500 micros we
are at the start of a new bit sequence

    decode(); //decode the bit sequence

  }

}

void decode() {

  sign=1;

```

```

value=0;

for (i=0;i<23;i++) {

    while (digitalRead(clockpin)==HIGH) { } //wait until clock returns to HIGH- the first
bit is not needed

    while (digitalRead(clockpin)==LOW) {} //wait until clock returns to LOW

    if (digitalRead(datapin)==LOW) {

        if (i<20) {

            value|= 1<<i;

        }

        if (i==20) {

            sign=-1;

        }

    }

}

result=(value*sign)/100.00;
lcd.clear();
lcd.print ( " Y= " );
lcd.print( result,2 );
// Serial.println(result,2); //print result with 2 decimals
lcd.print ( " mm");
lcd.setCursor (0,1);// move cursor to line two
lcd.print ( " Y= " );
lcd.print ( (result/25.4),4 );
lcd.print ( " inch");

delay(100);

}

```

As I used a Pro Mini I needed a regulated 5v power supply, also callipers needed a regulated 1.5v supply, a couple of voltage regulator circuits dealt with this quite easily. The output from callipers (SDA & CLK) are at 1.5v and the Arduino needs an input of 5.0v I therefore used a couple of transistors as level shifters. The display is a 16x2 I2C lcd. This is a serial display and only uses two Arduino ports leaving plenty free for future developments.

The whole unit is powered from "the mains UK 240v AC" by a cheap and cheerful 12v DC wall adapter found on many modern pieces of electronic equipment. I have a box full of these for different voltage output from scrapped electronic stuff... Any adaptor giving out between 7v and 14v should work. If you go any higher with input voltage it could cause a lot of overheating in the circuits, any lower and the voltage regulator ICs will probably be erratic.

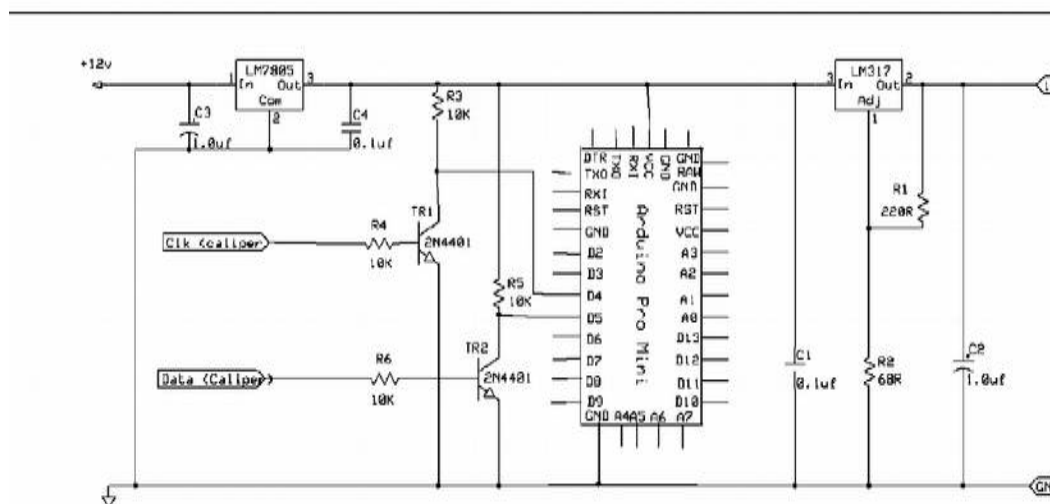

This is the circuit that I made on strip board. Below are two pictures of the layout on the board as done in Lock-master software.

CHECK THE CONNECTION LAYOUT ON YOUR ARDUINO.....ALL PRO MINIS ARE NOT THE SAME LAYOUT.

I bought 10 units from china via flea-bay at approx £1.50 each.. Just the job for embedding in a project.

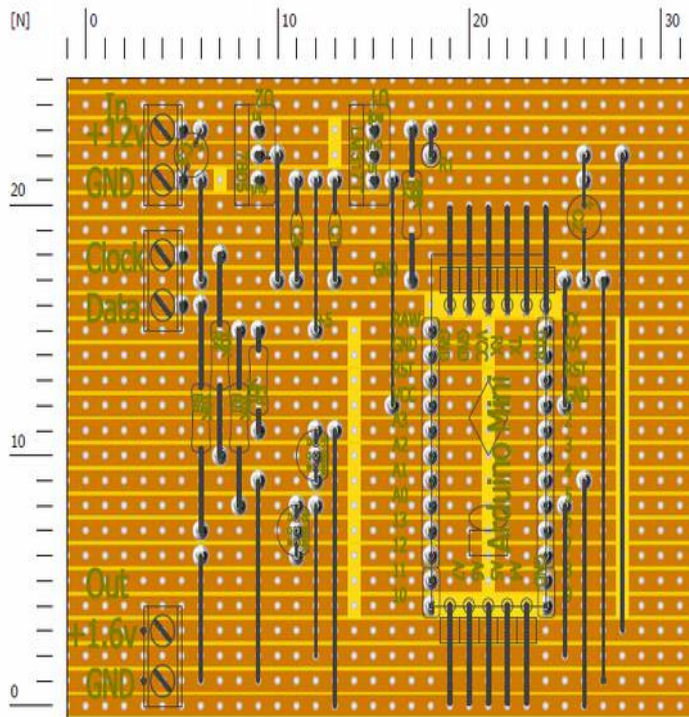
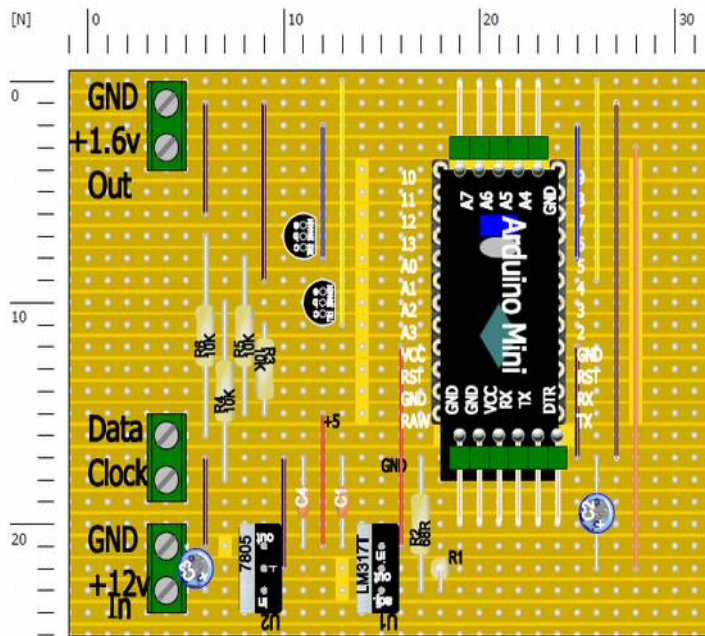

NOTE

I have found how to reset Zero from remote unit but would need to resolder and replace cable from calliper to display box. I will not bother on lathe but will fit on mill with 3 Axis readout????

Below is a picture of my finished set-up before final fitting.

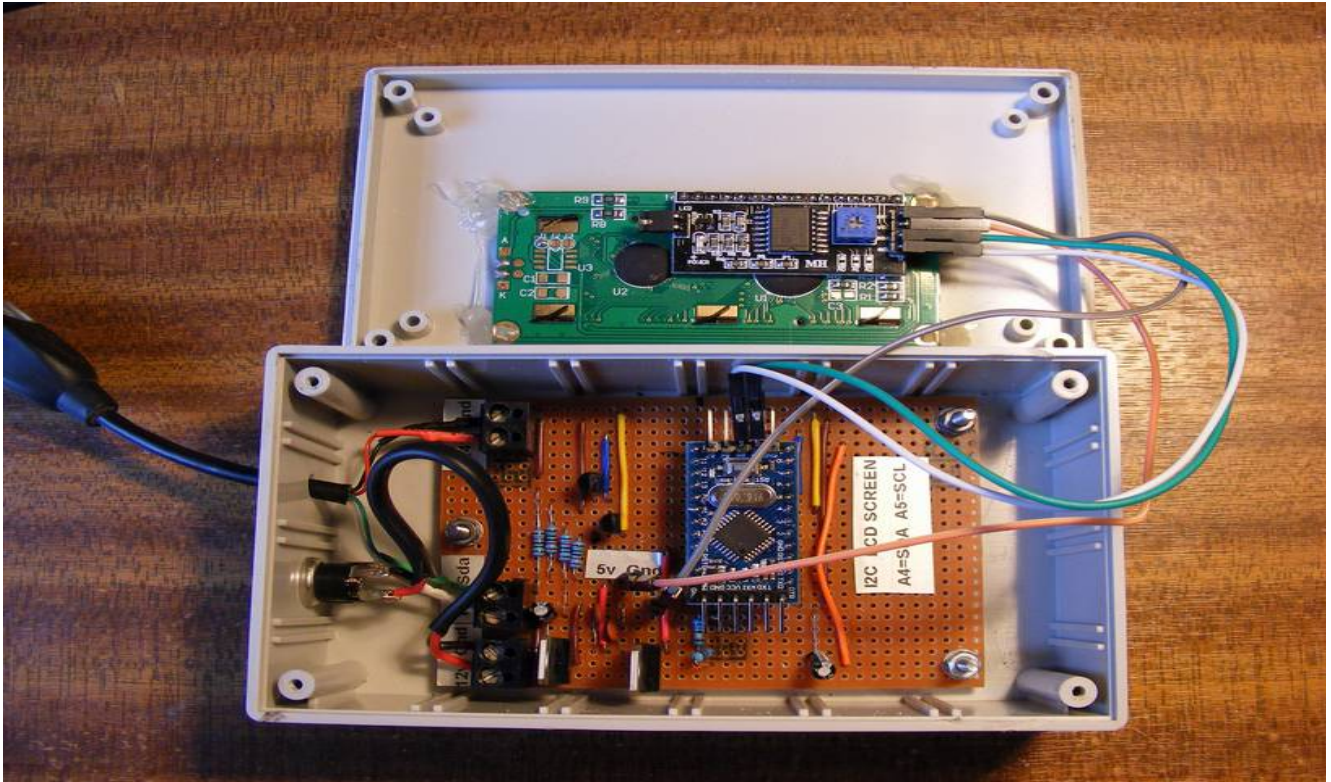

Modified Calliper and display being tested before fitting.



Calliper fitted to lathe.

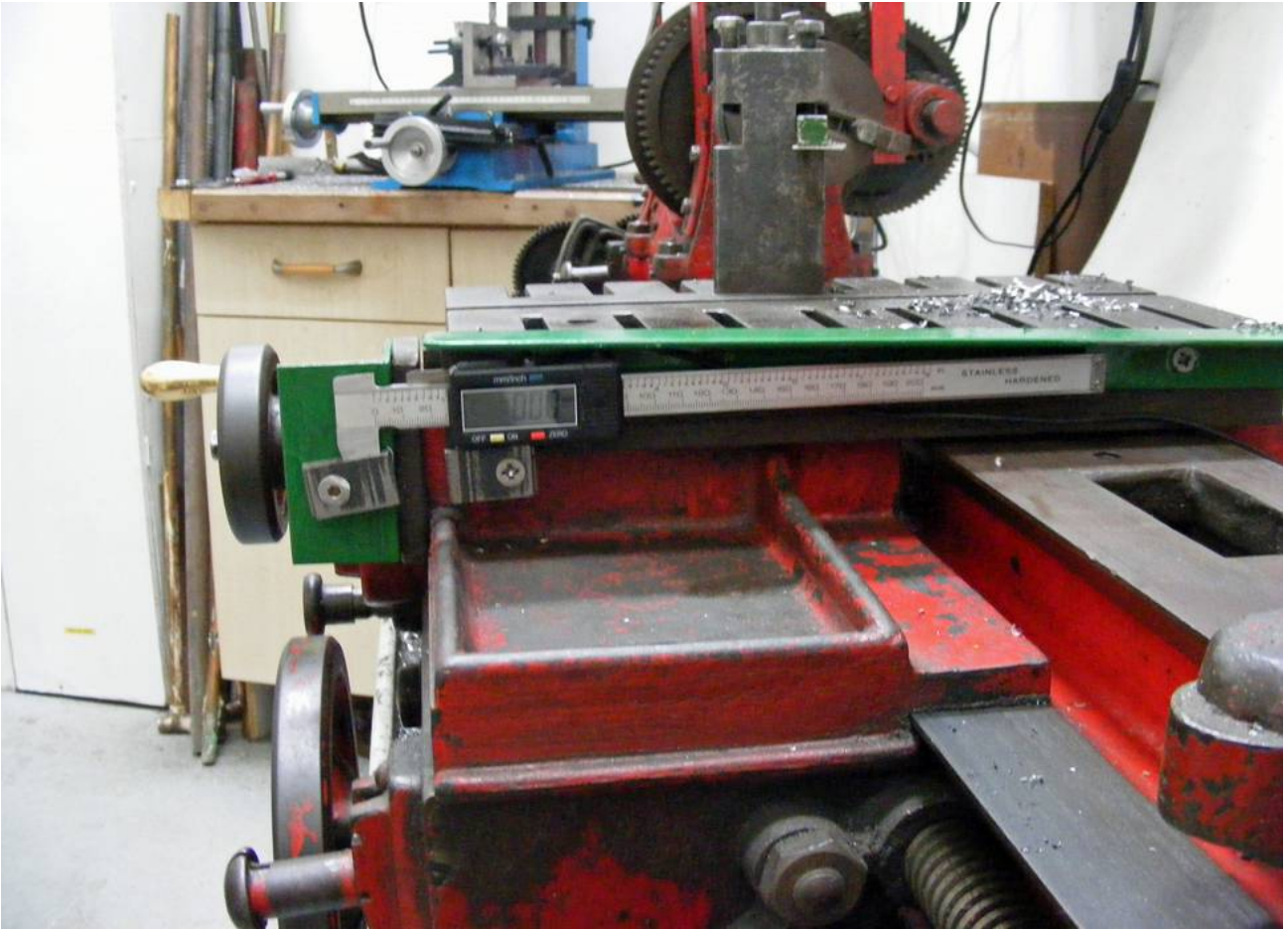

I am going to improve the mounting brackets when time permits.

References,

<https://sites.google.com/site/marthaprojects/home/arduino/arduino-reads-digital-caliper>

<https://pylin.com/2017/05/26/reading-digital-caliper-from-arduino/>

http://www.shumatech.com/support/chinese_scales.htm#Introduction

I hope that this article has been of interest and help and will answer questions if I can.

Article on Tachometer and 3 axis DRO to follow when I get them finished.

KEEP MAKING SWARF..