

PARTS LIST			
ITEM	QTY	PART NUMBER	DESCRIPTION
1	1	Assy, Baseplate	
2	1	Assy, Flywheel	
3	2	Assy, Cylinder	
4	1	Assy, Walking Beam	
5	1	Assy, Piston	
6	2	Assy - Cam Follower	
7	2	Assy, Valve	
8	2	Spring, Compression, TBD	

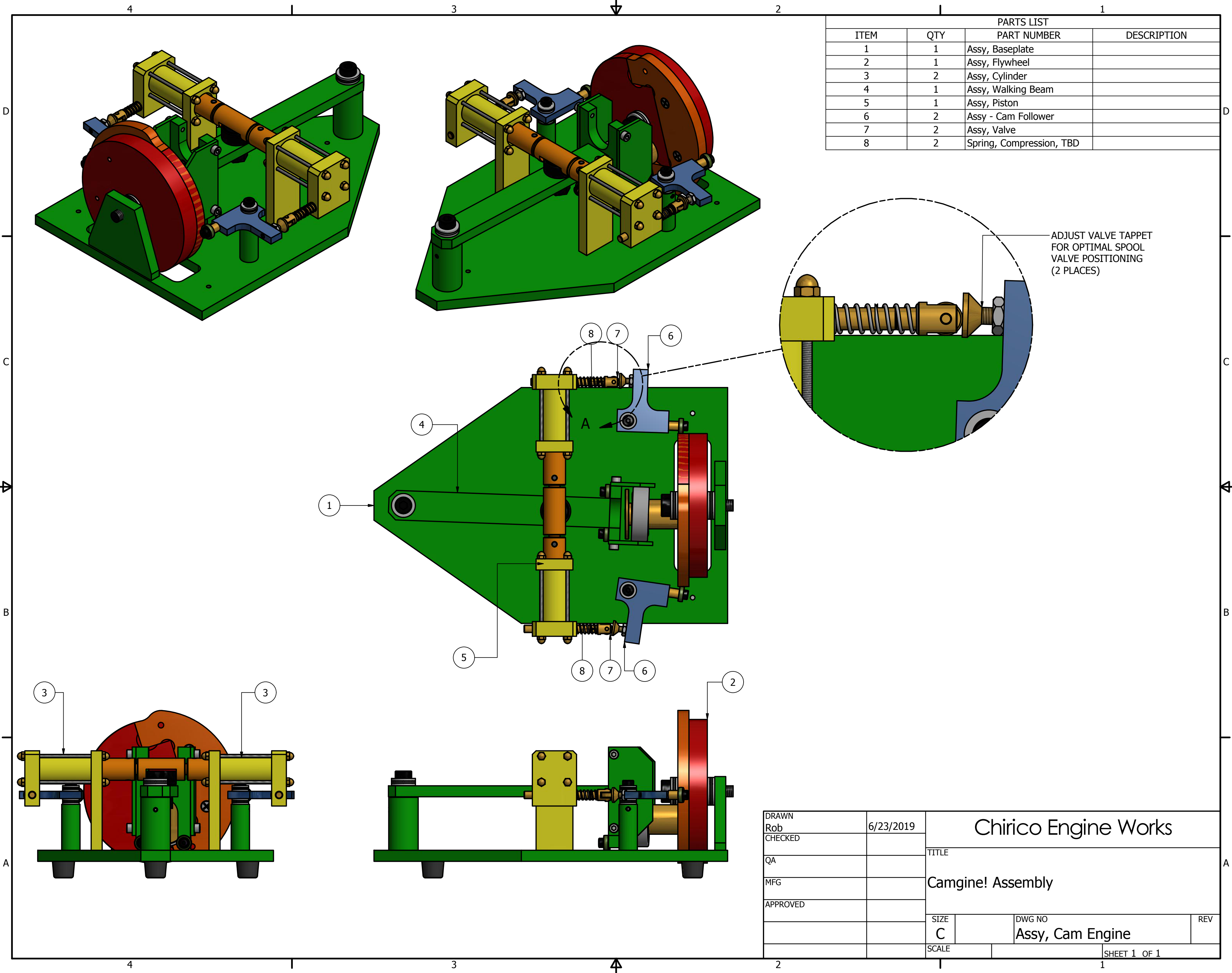

DRAWN Rob	6/23/2019	Chirico Engine Works		
CHECKED		TITLE		
QA		Camgine! Assembly		
MFG		SIZE C	DWG NO Assy, Cam Engine	REV
APPROVED		SCALE	SHEET 1 OF 1	

4

3

2

1

PARTS LIST

ITEM	QTY	PART NUMBER	DESCRIPTION
1	1	End Plate, Cylinder	MATERIAL: 6061 AL
2	1	Cylinder	MATERIAL: ø1.00 OD X .125 WALL AL TUBING
3	1	Head, Cylinder	BRASS OR ALUMINUM
4	4	Tie Rod, Cylinder	4-40 ALLTHREAD ROD
5	8	0400NAB	#4-40 ACORN NUT (SS OR BRASS)
8	1	020 O-Ring	

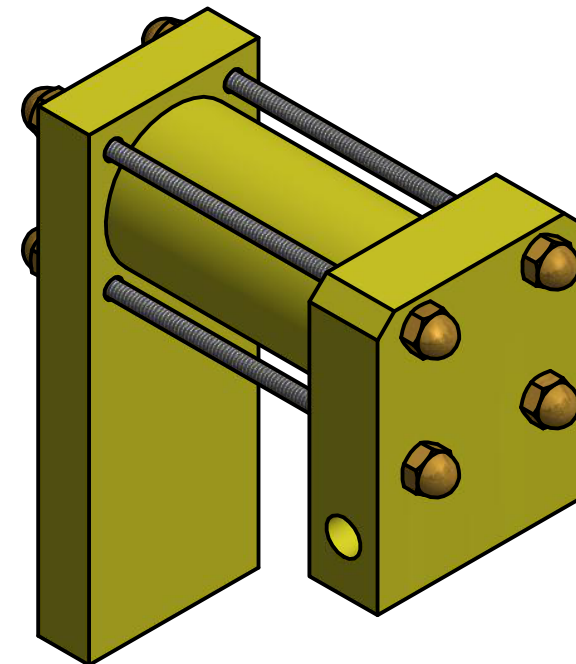
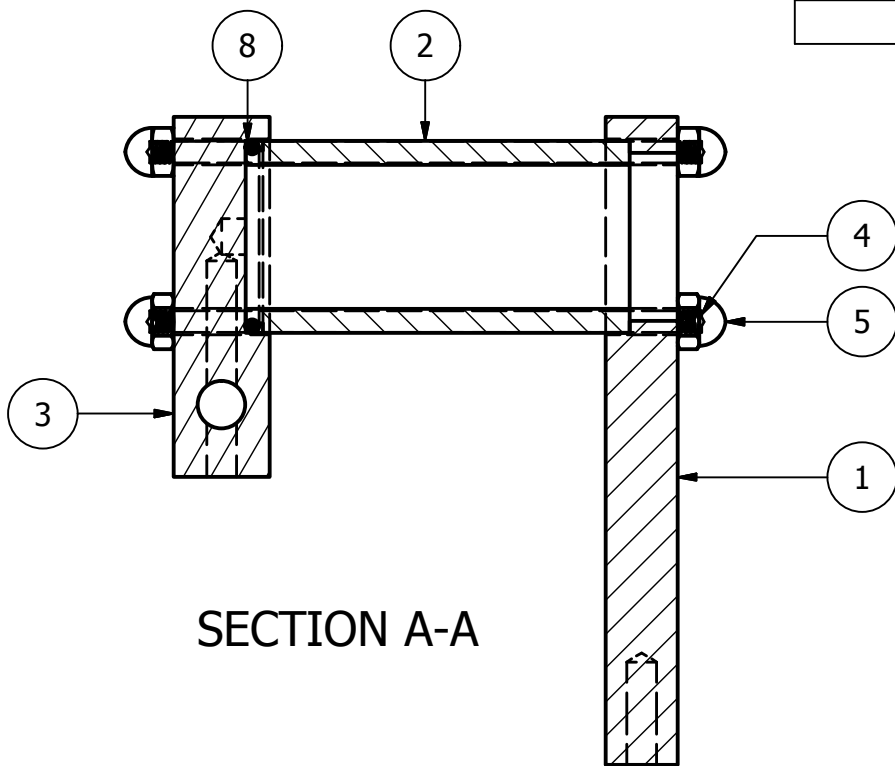
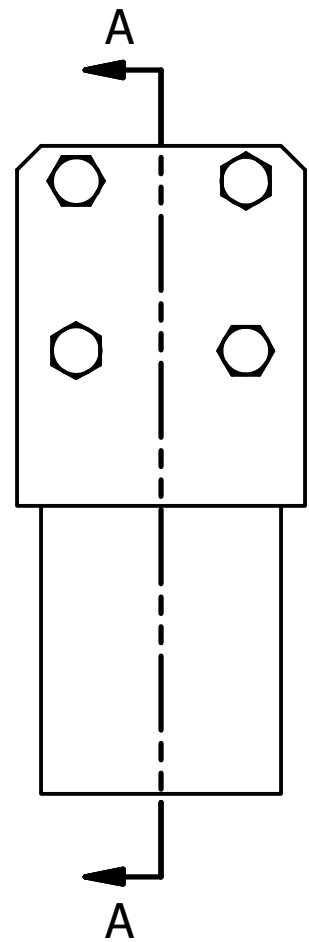

SECTION A-A

B

B

A

A

A

A

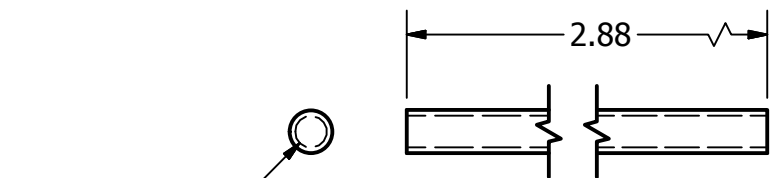

TIE ROD, CYLINDER

DRAWN Rob	4/21/2019	Chirico Engine Works		
CHECKED		TITLE		
QA		CYLINDER ASSEMBLY		
MFG		SIZE B	DWG NO Assy, Cylinder	REV
APPROVED		SCALE	SHEET 1 OF 1	

4

3

2

1

A

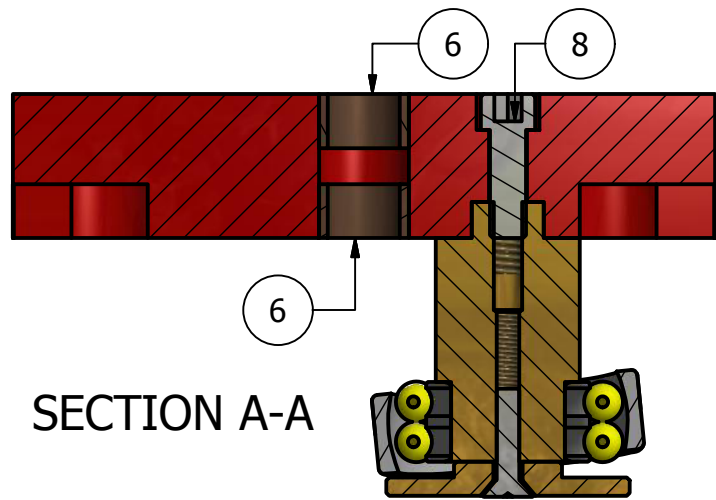

SECTION A-A

PARTS LIST			
ITEM	QTY	PART NUMBER	TITLE
1	1	Cam	CAM
2	1	Flywheel	FLYWHEEL
3	1	Ball Post, Flywheel	BEARING POST
4	1	Spherical Limiter	SPERICAL BEARING LIMITER
5	1	1204_01	BEARING, 1204
6	2	6391K211 Sleeve Bearing, 1_2 x 5_8od x 3_8 lg	
7	3	1112FHPS	#10-32 X 3/4" LG FLAT HEAD SCREW
8	1	2512SHCS	1/4-20 X 3/4" LG SHCS

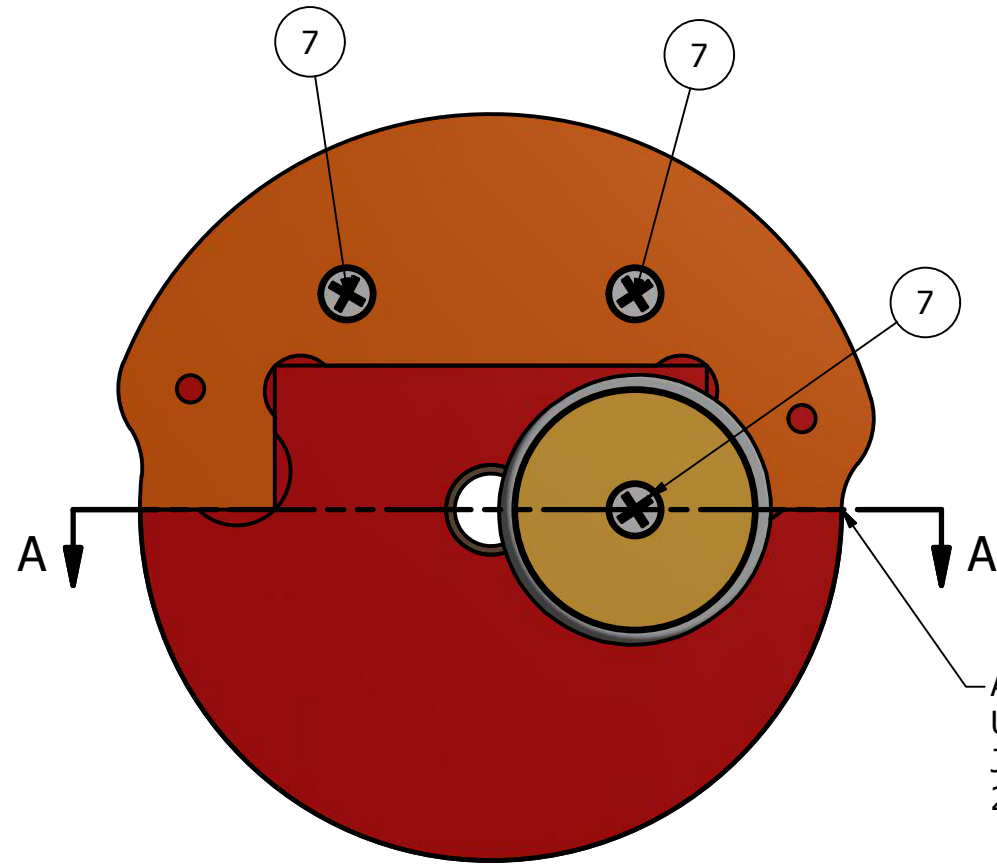

AFTER ASSEMBLY,
USE A FILE TO SMOOTH
JUNCTION IF REQUIRED
2 PLACES

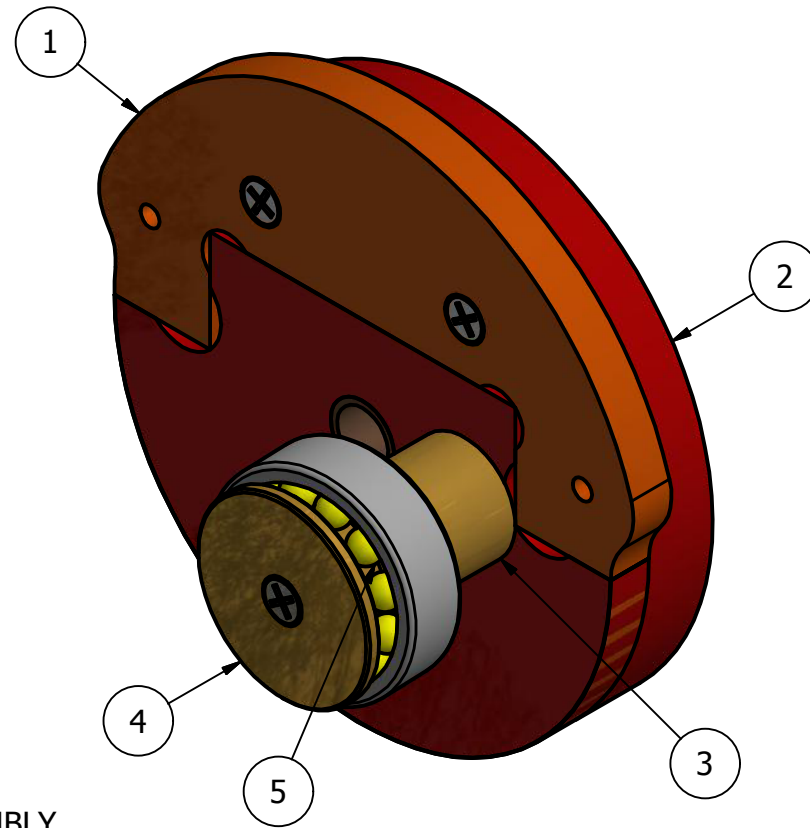

DRAWN Rob	3/31/2019	Chirico Engine Works		
CHECKED		TITLE		
QA		FLYWHEEL ASSEMBLY		
MFG		SIZE B	DWG NO Assy, Flywheel	REV
APPROVED		SCALE	SHEET 1 OF 1	

4

3

2

1

PARTS LIST			
ITEM	QTY	PART NUMBER	DESCRIPTION
3	1	Piston Center	MATERIAL: BRASS
4	2	Piston	MATERIAL: 6061 AL
5	2	Piston Ring	#016 PTFE ORING (McM 9559K22)
6	2	Pin, Piston Joint	MATERIAL: BRASS OR CRS

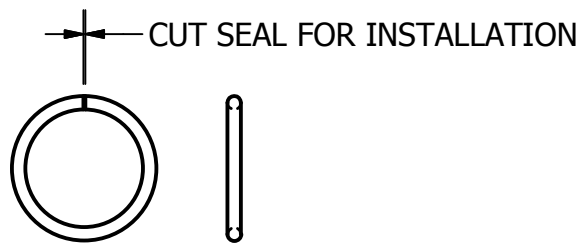

PISTON RING

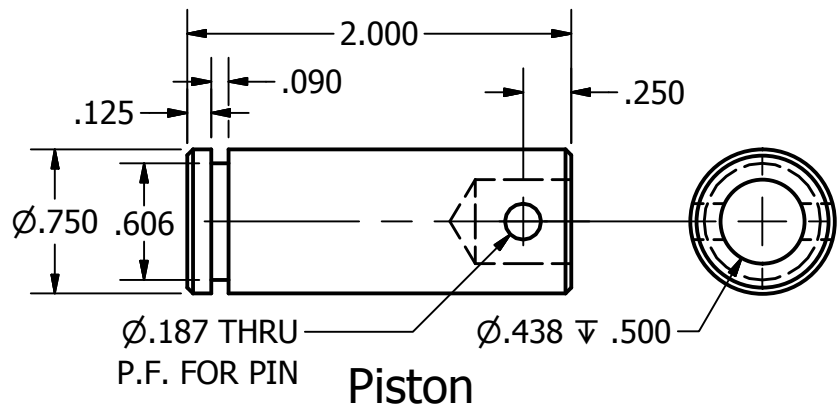

Piston

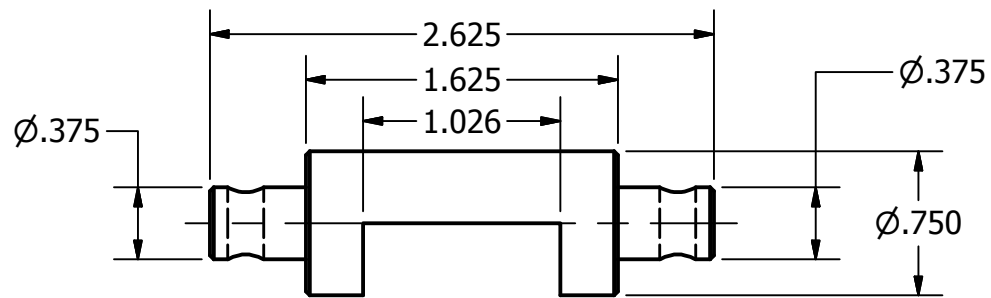

2X Ø.189 THRU S.F. FOR PIN
Piston Center

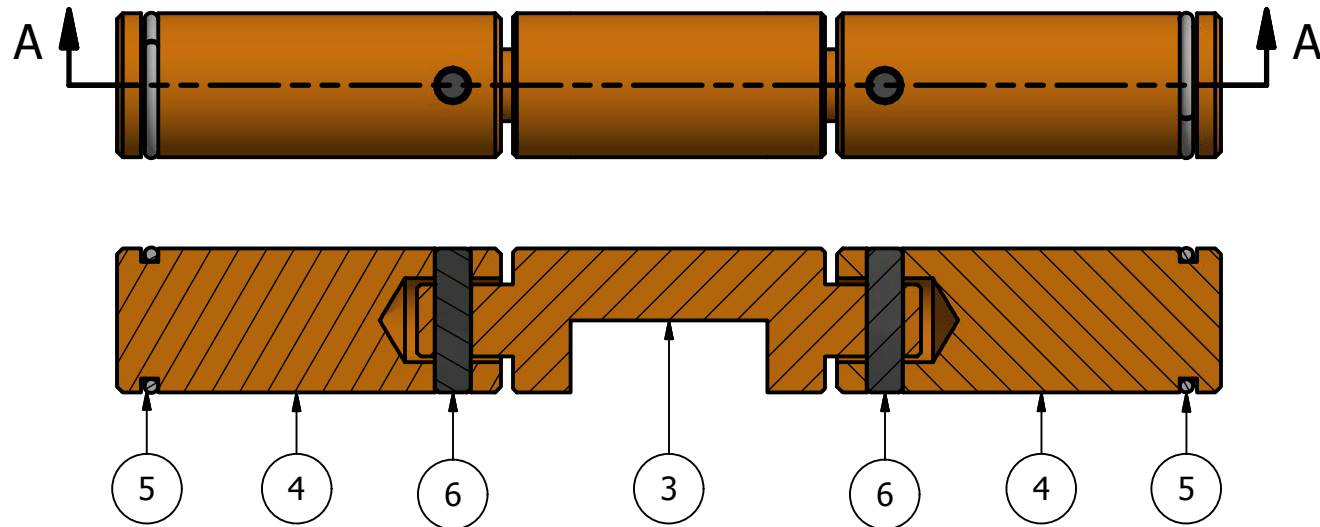
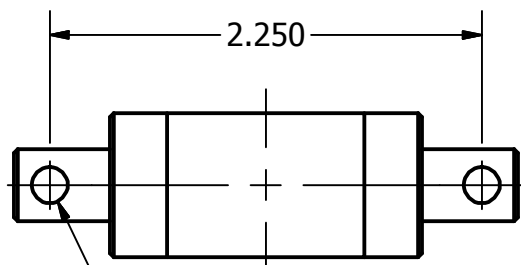

SECTION A-A

DRAWN Rob	4/21/2019	Chirico Engine Works	
CHECKED		TITLE	
QA		PISTON RING	
MFG		SIZE B	DWG NO Assy, Piston
APPROVED		SCALE	REV
			SHEET 1 OF 1

B

B

A

A

A

4

3

2

1

4

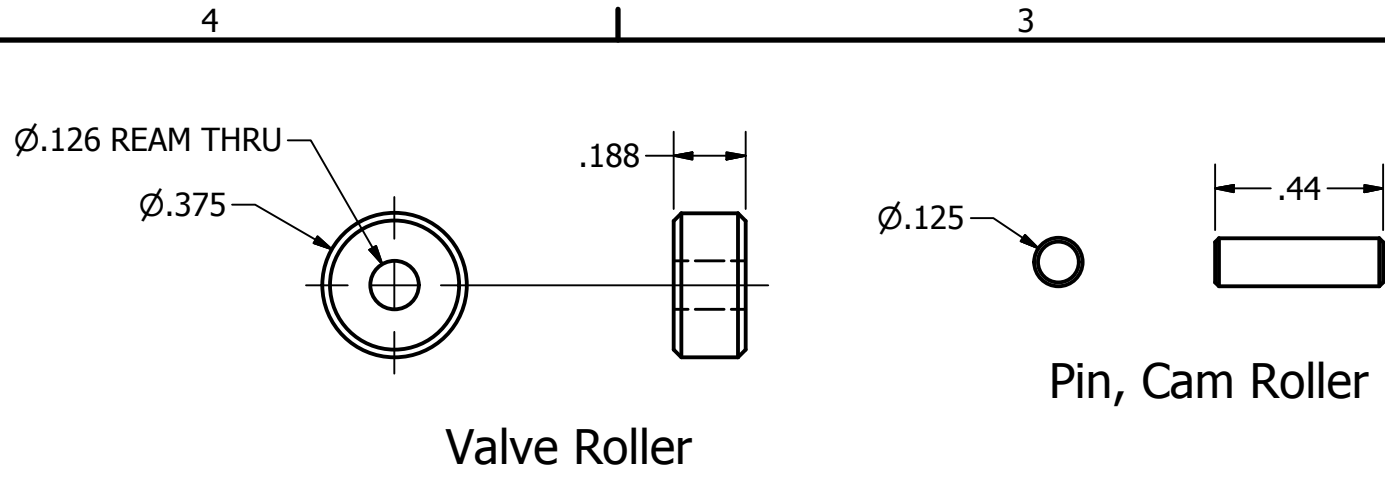

PARTS LIST			
ITEM	QTY	PART NUMBER	DESCRIPTION
1	1	Vavle	BRASS
2	1	Valve Rod Joint 01	BRASS
3	1	Valve Roller	Material: Brass
5	1	Pin, Cam Roller	Material: Brass
6	1	1108COPS	10-32 X 1/2 CUP POINT SETSCREW

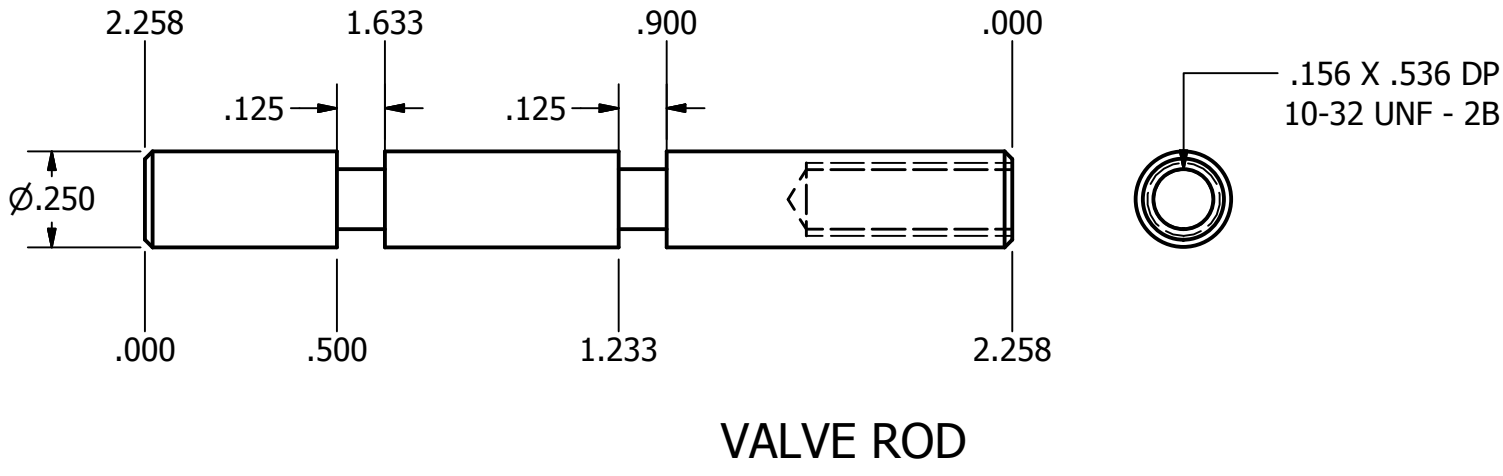
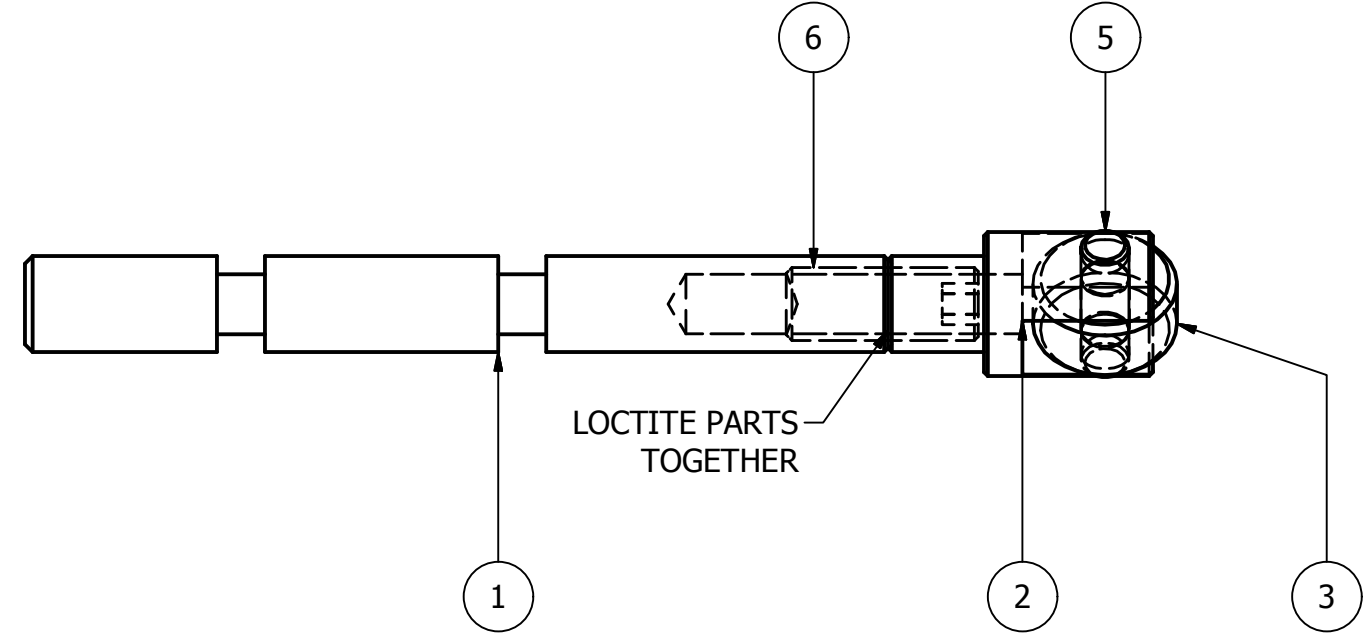
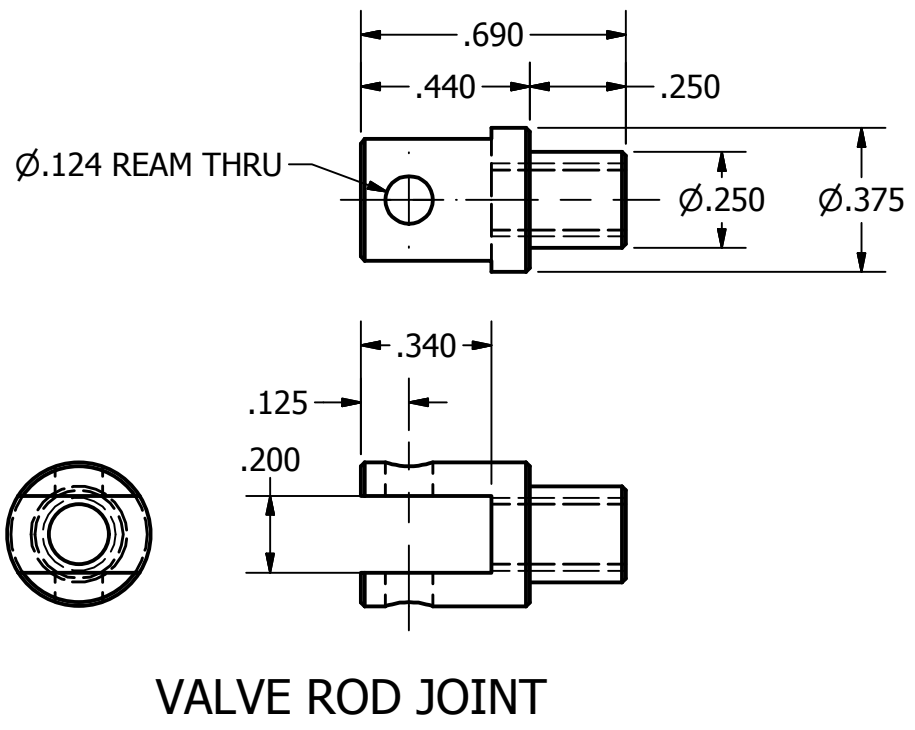

DRAWN Rob	4/21/2019	Chirico Engine Works	
CHECKED		TITLE	
QA		VALVE ASSEMBLY	
MFG		SIZE B	DWG NO Assy, Valve
APPROVED		SCALE	REV
		SHEET 1 OF 1	

PARTS LIST			
ITEM	QTY	PART NUMBER	DESCRIPTION
1	1	Ball Post, Flywheel	MATERIAL: 6061 AL

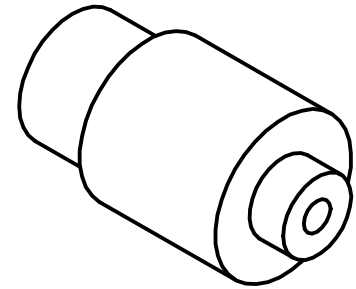
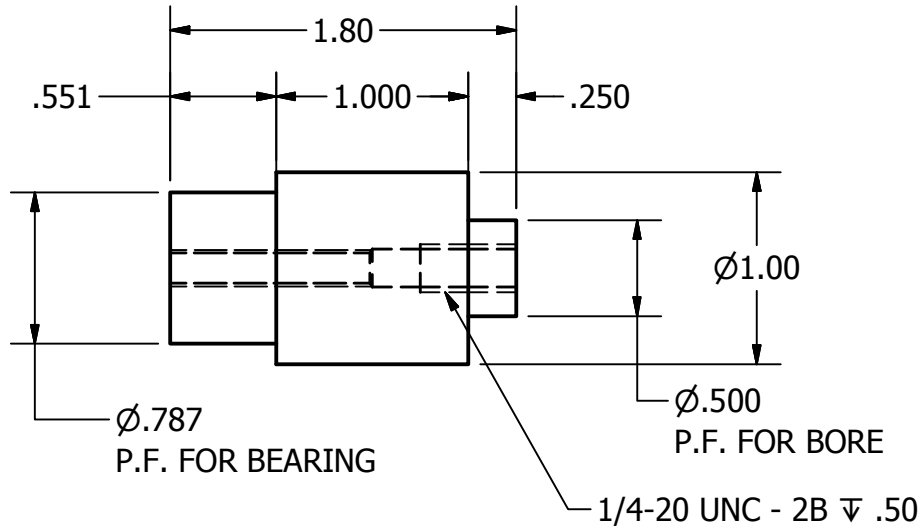

DRAWN	3/31/2019
Rob	
CHECKED	
QA	
MFG	
APPROVED	

Chirico Engine Works			
TITLE			
BEARING POST			
SIZE		DWG NO	REV
A		Ball Post, Flywheel	1
SCALE		SHEET 1 OF 1	

PARTS LIST			
ITEM	QTY	PART NUMBER	DESCRIPTION
1	1	Baseplate	MATERIAL: 6061 AL

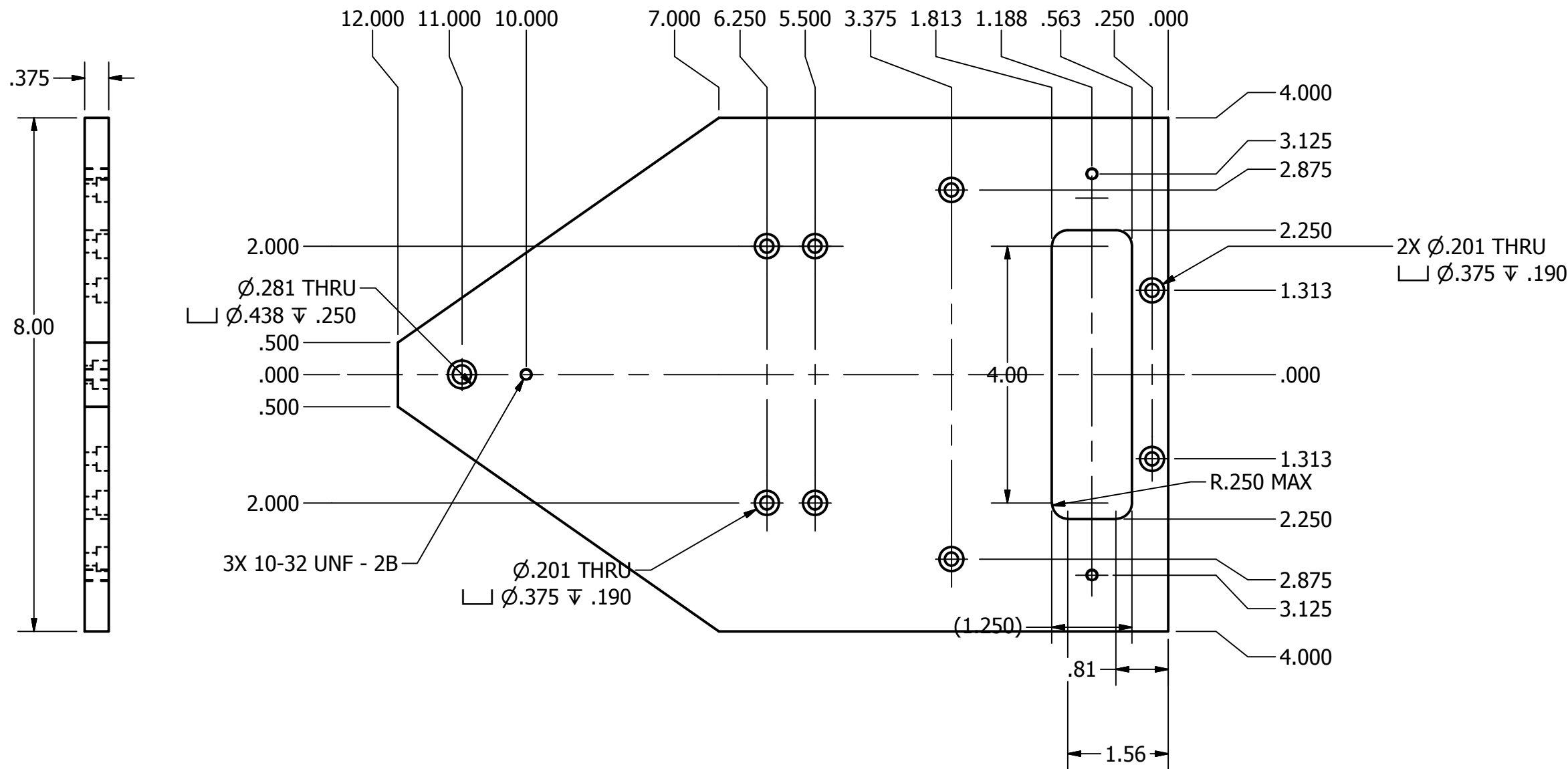

DRAWN Rob	3/31/2019	Chirico Engine Works		
CHECKED		TITLE		
QA		BASE PLATE		
MFG				
APPROVED				
		SIZE B	DWG NO Baseplate	REV
		SCALE		SHEET 1 OF 1

PARTS LIST			
ITEM	QTY	PART NUMBER	DESCRIPTION
1	1	Cam Pivot	MATERIAL: 6061 AL

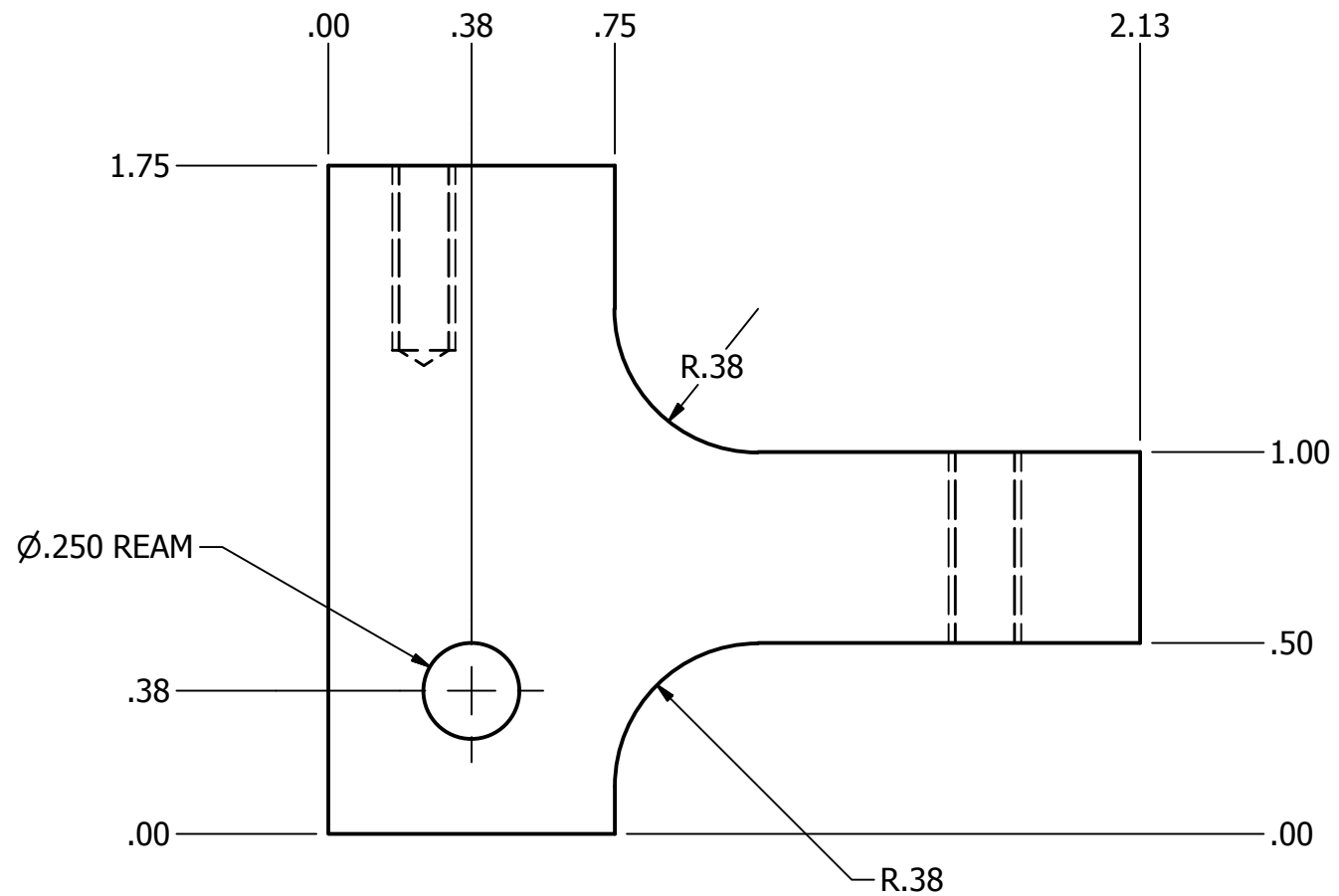
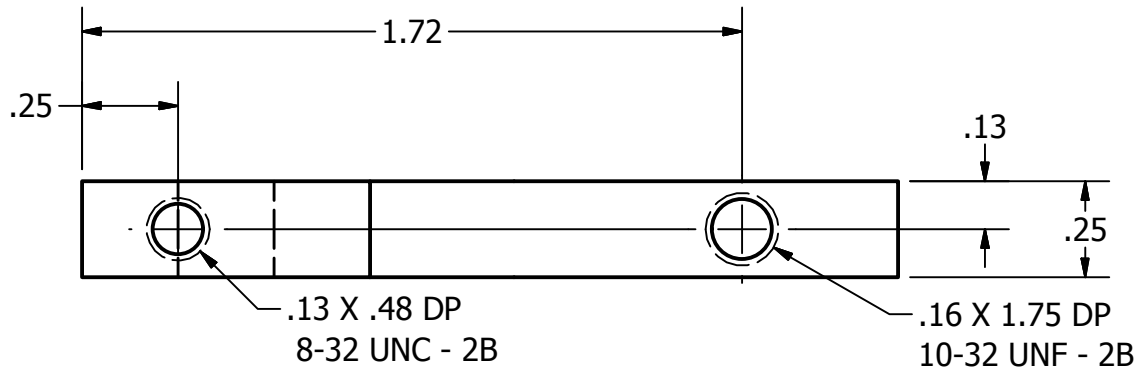

DRAWN Rob	4/20/2019	Chirico Engine Works		
CHECKED		TITLE		
QA		CAM PIVOT PLATE		
MFG				
APPROVED				
		SIZE B	DWG NO Cam Pivot	REV
		SCALE		SHEET 1 OF 1

PARTS LIST			
ITEM	QTY	PART NUMBER	DESCRIPTION
1	1	Cam	MATERIAL: 6061 AL - HARD ANODIZED AFTER MACHINING

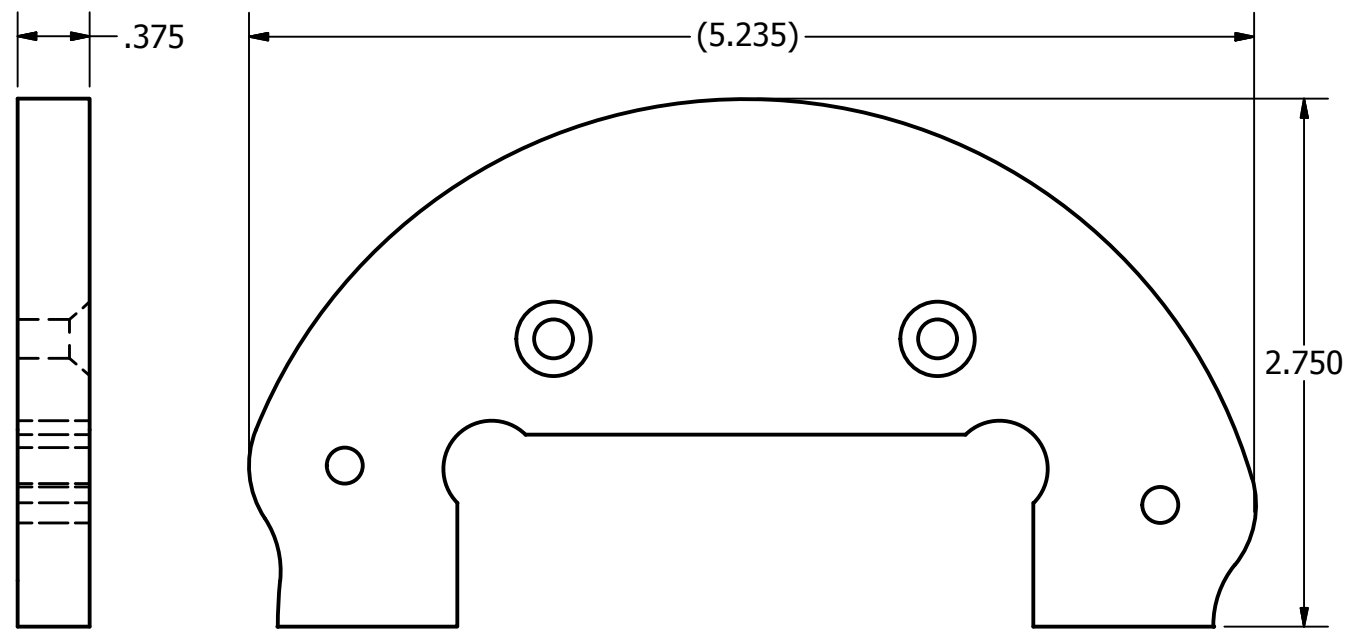
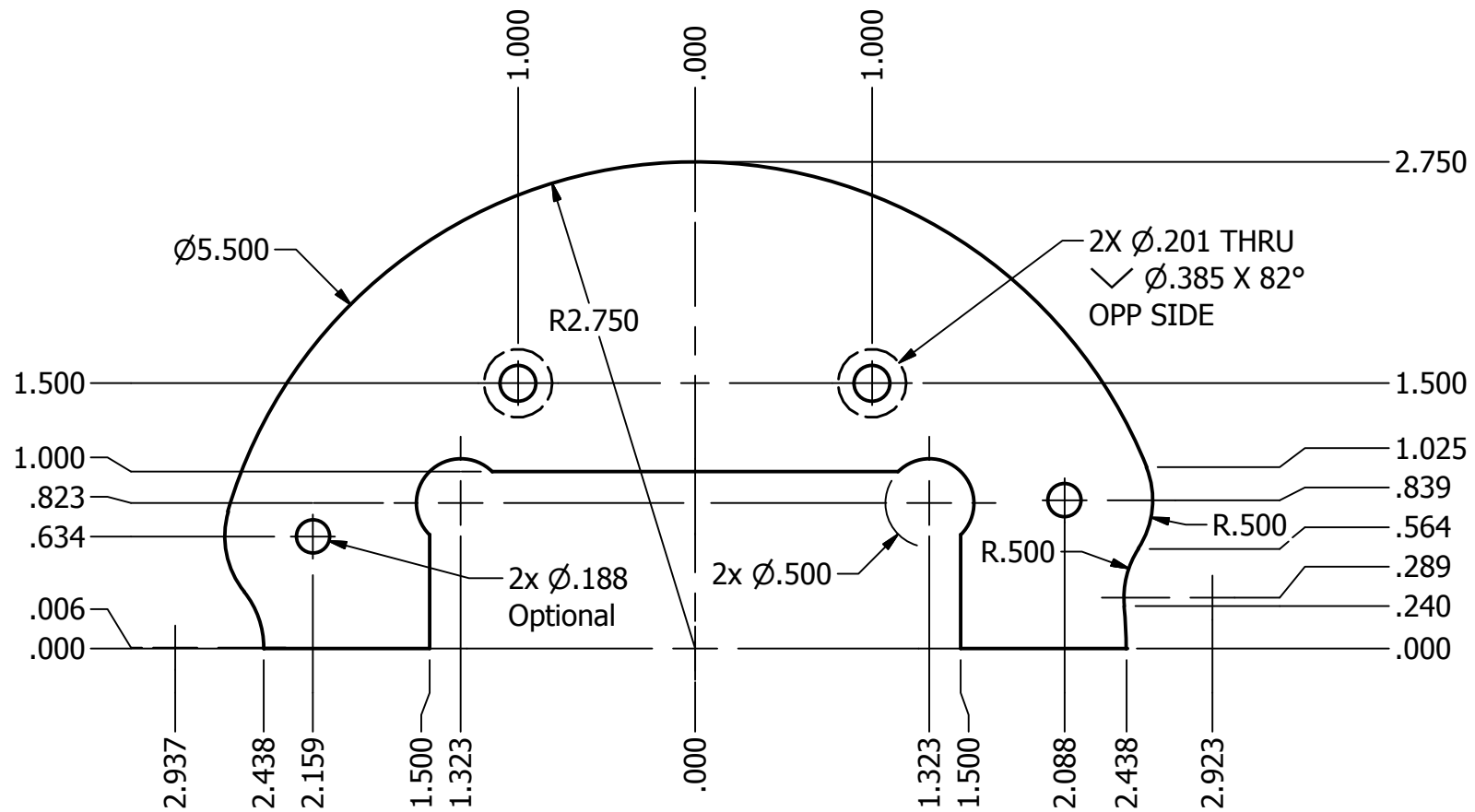

DRAWN Rob	3/31/2019	GHIRIGO ENGINE WORKS		
CHECKED		TITLE		
QA		CAM		
MFG				
APPROVED				
		SIZE B	DWG NO Cam	REV
		SCALE		SHEET 1 OF 1

2



1

PARTS LIST			
ITEM	QTY	PART NUMBER	DESCRIPTION
1	1	Cylinder	MATERIAL: ϕ 1.00 OD X .125 WALL AL TUBING

B

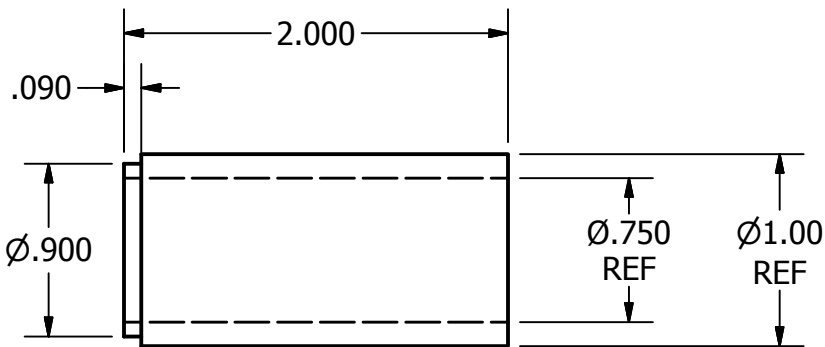
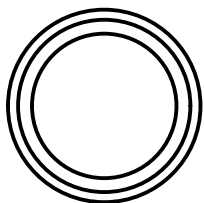

B



A

A

DRAWN Rob	4/20/2019	Chirico Engine Works		
CHECKED				
QA		TITLE		
MFG				
APPROVED				
		SIZE A	DWG NO Cylinder	REV
		SCALE		SHEET 1 OF 1

2



1

PARTS LIST			
ITEM	QTY	PART NUMBER	DESCRIPTION
1	1	End Plate, Cylinder	MATERIAL: 6061 AL

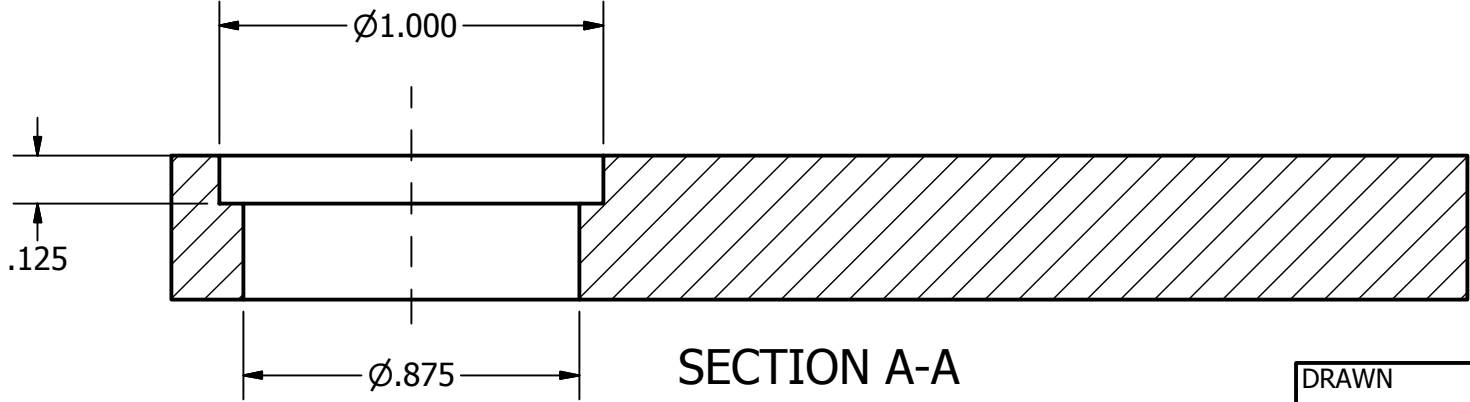
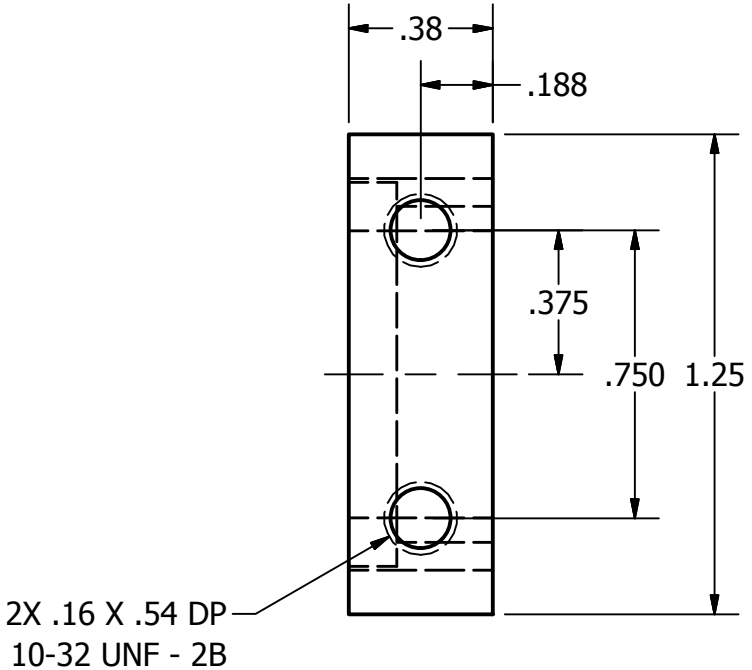
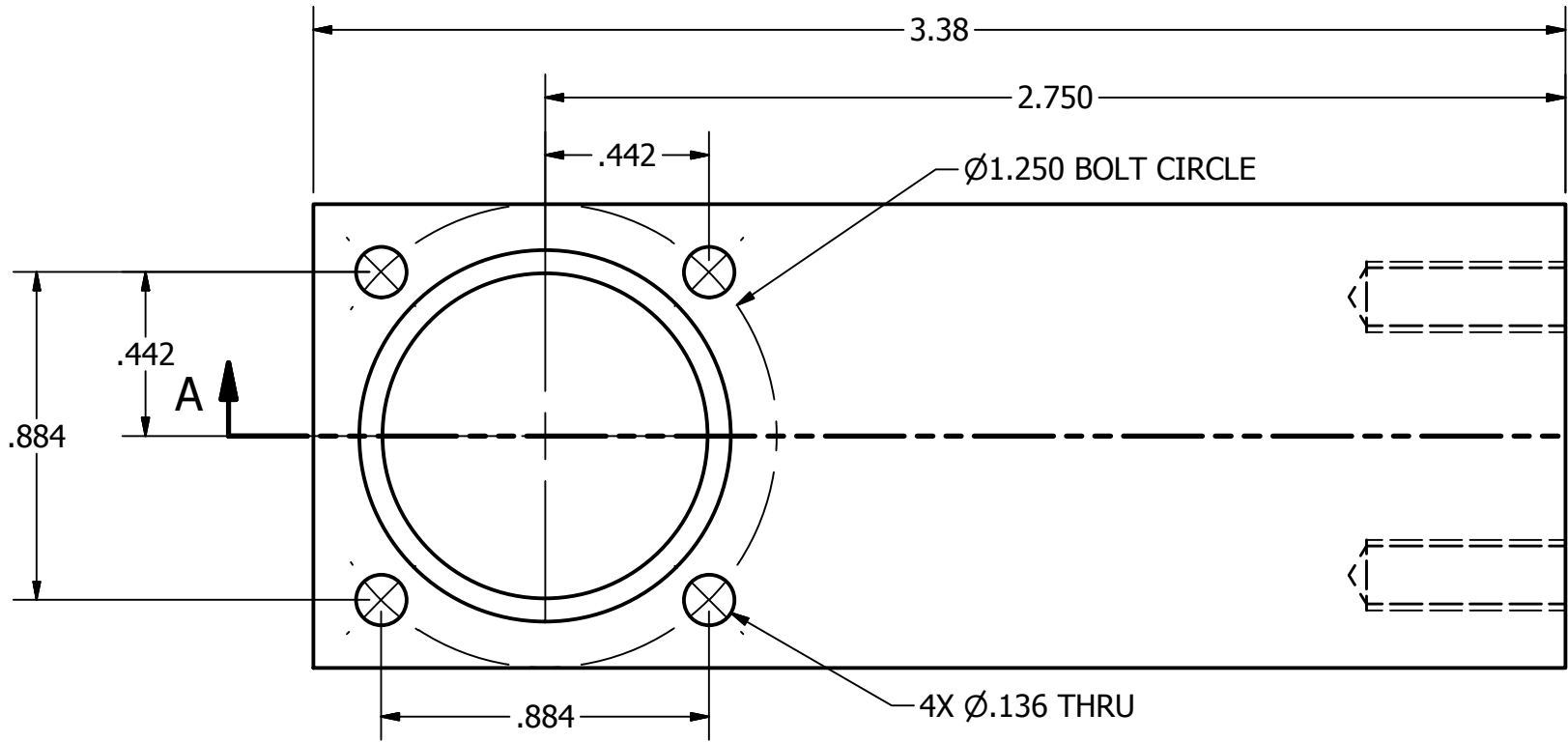

DRAWN Rob	4/20/2019	Chirico Engine Works		
CHECKED				
QA		TITLE		
MFG				
APPROVED				
		SIZE B	DWG NO End Plate, Cylinder	REV
		SCALE	SHEET 1 OF 1	

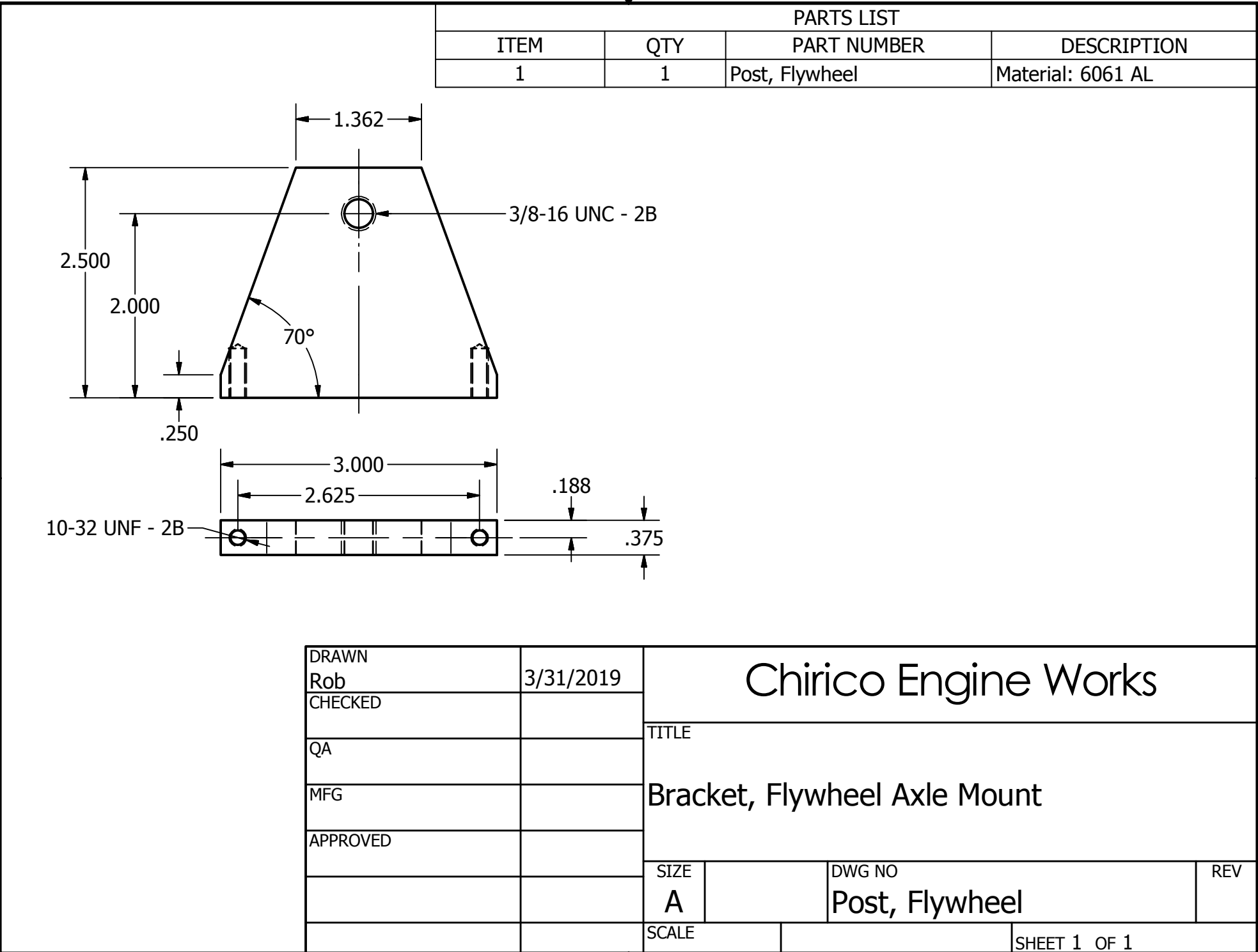

PARTS LIST			
ITEM	QTY	PART NUMBER	DESCRIPTION
1	1	Post, Flywheel	Material: 6061 AL

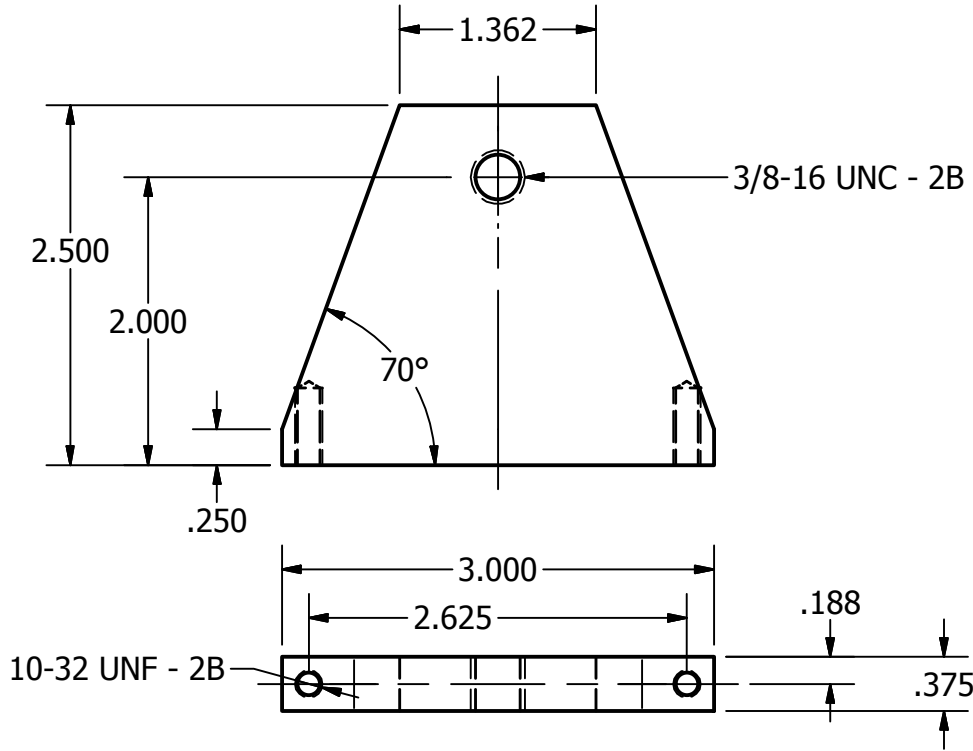

DRAWN	Rob	3/31/2019	Chirico Engine Works	
CHECKED	QA		TITLE	
MFG	APPROVED		Bracket, Flywheel Axle Mount	
			SIZE	DWG NO
			A	Post, Flywheel
			SCALE	REV
				SHEET 1 OF 1

PARTS LIST			
ITEM	QTY	PART NUMBER	DESCRIPTION
1	1	Head, Cylinder	BRASS OR ALUMINUM

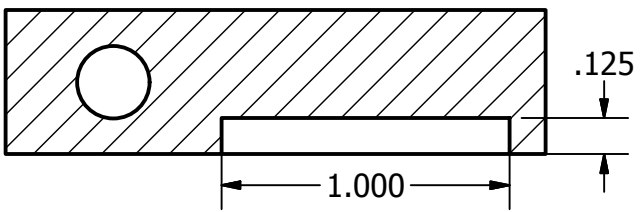

SECTION A-A

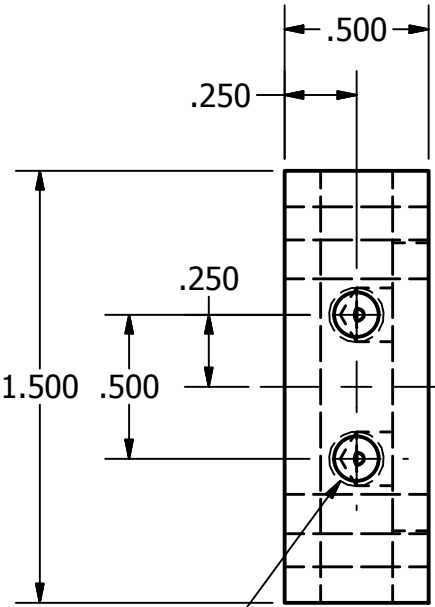
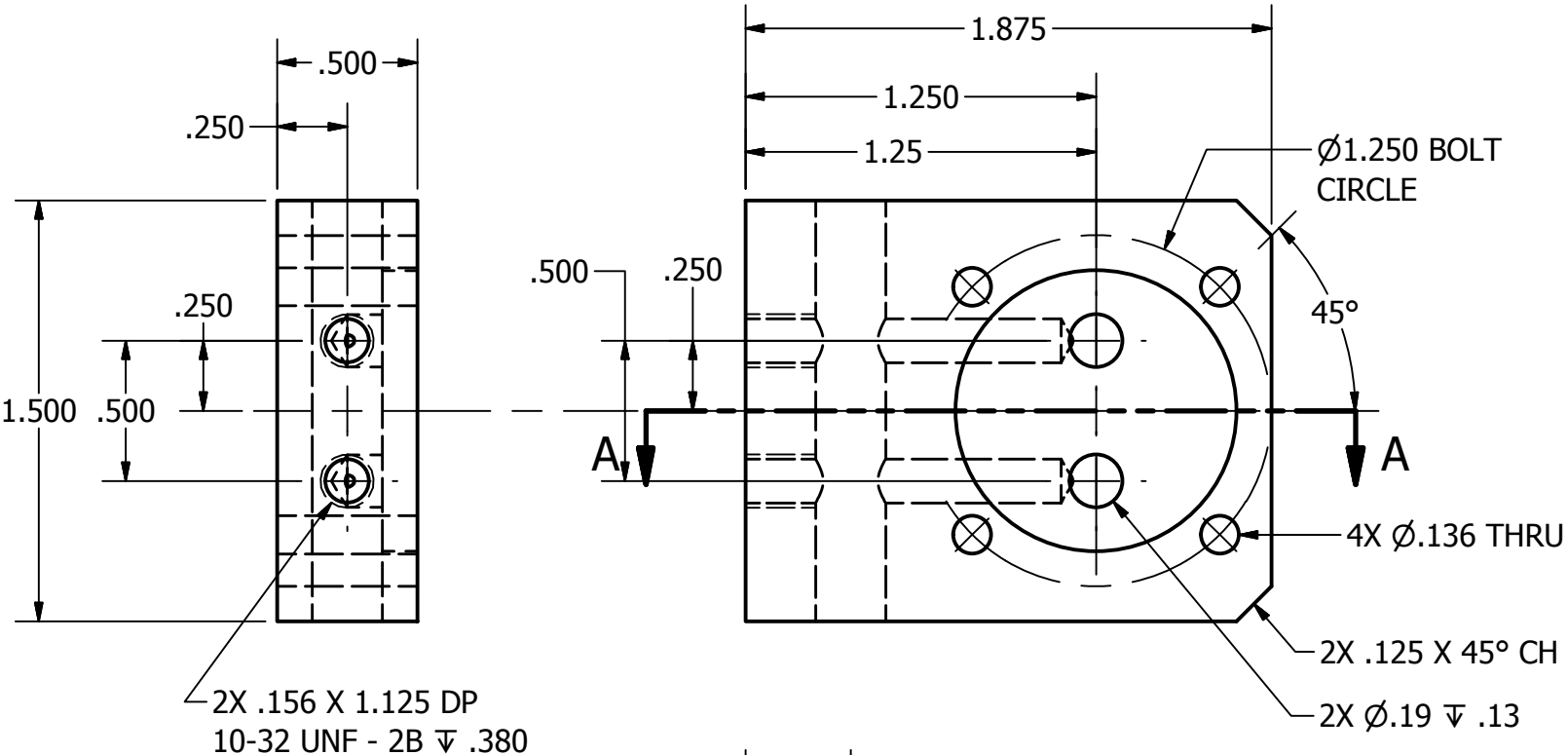

2X .156 X 1.125 DP
10-32 UNF - 2B ∇ .380

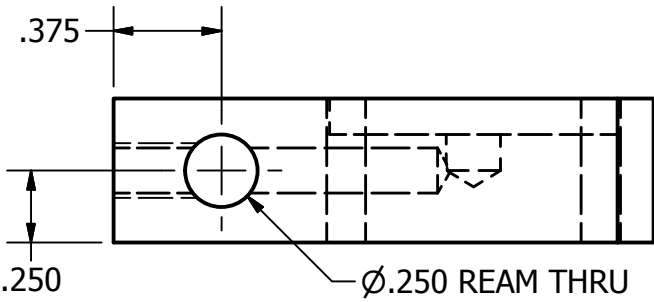

Ø.250 REAM THRU

DRAWN Rob	4/21/2019	Chirico Engine Works	
CHECKED			
QA		TITLE	
MFG		CYLINDER HEAD	
APPROVED		SIZE B	DWG NO Head, Cylinder
		SCALE	REV
		SHEET 1 OF 1	

PARTS LIST			
ITEM	QTY	PART NUMBER	DESCRIPTION
1	1	Spacer, Cam Follower	MATERIAL: AL OR BRASS

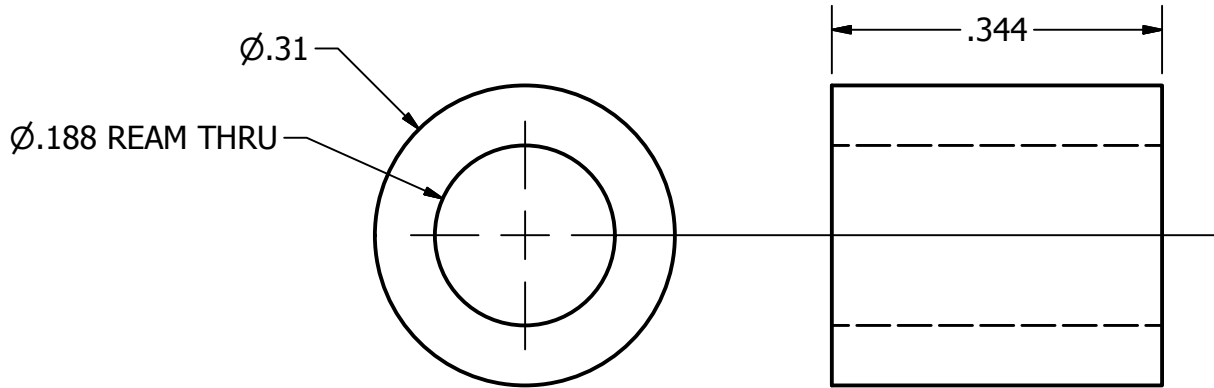

DRAWN Rob	4/20/2019	Chirico Engine Works		
CHECKED				
QA		TITLE		
MFG				
APPROVED				
		SIZE A	DWG NO Spacer, Cam Follower	REV
		SCALE		SHEET 1 OF 1

PARTS LIST			
ITEM	QTY	PART NUMBER	DESCRIPTION
1	1	Spherical Limiter	MATERIAL: 6061 AL

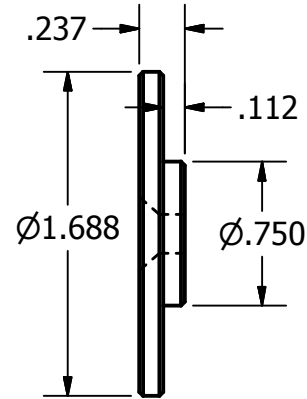
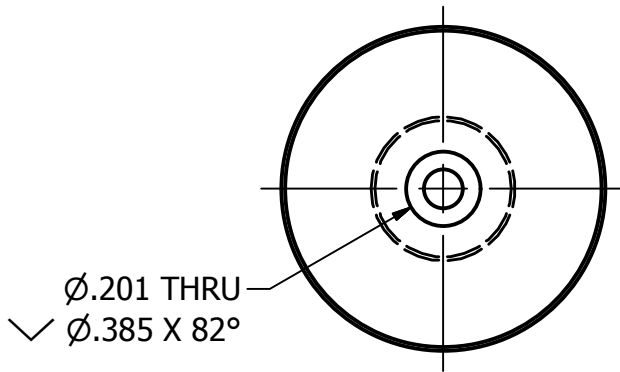

DRAWN Rob	6/23/2019	Chirico Engine Works	
CHECKED			
QA		TITLE	
MFG		SPERICAL BEARING LIMITER	
APPROVED		SIZE A	DWG NO Spherical Limiter
		SCALE	REV
			SHEET 1 OF 1

PARTS LIST			
ITEM	QTY	PART NUMBER	DESCRIPTION
1	1	Valve Tappet	MATERIAL: BRASS

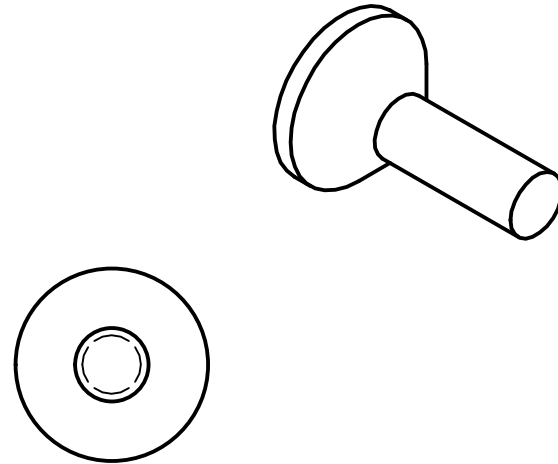
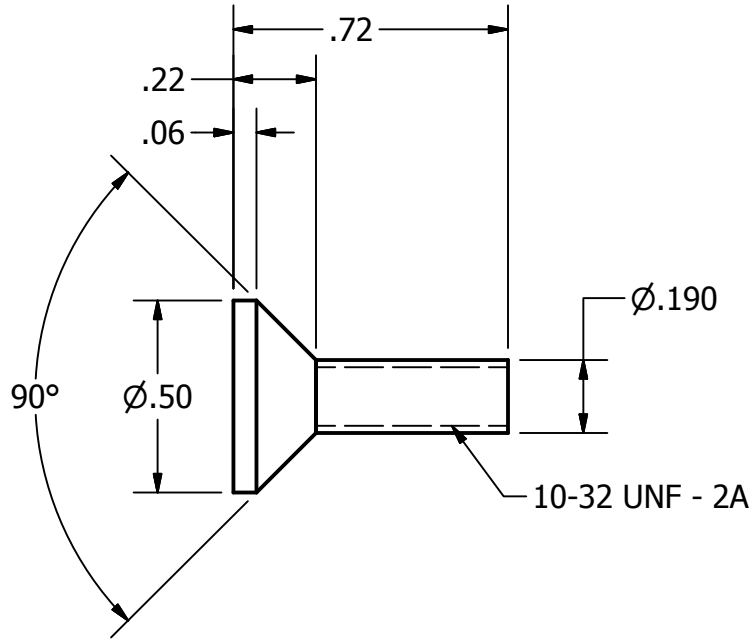

DRAWN Rob	4/20/2019
CHECKED	
QA	
MFG	
APPROVED	

Chirico Engine Works			
TITLE			
SIZE A	DWG NO Valve Tappet	REV	
SCALE		SHEET 1 OF 1	

PARTS LIST			
ITEM	QTY	PART NUMBER	TITLE
1	1	Cam Pivot	CAM PIVOT PLATE
2	1	60355K502_BALL BEARING	
3	1	.188 dia x .500 lg x 8-32 thread Shoulder Screw	
4	1	Spacer, Cam Follower	
5	1	Valve Tappet	
6	1	1104COPS	10-32 X 1/4 CUP POINT SETSCREW
7	1	1100NHS	10-32 HEX NUT

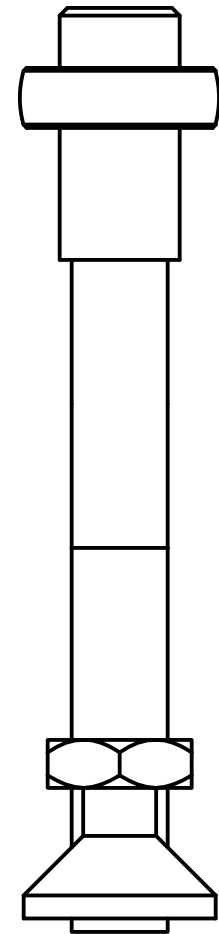
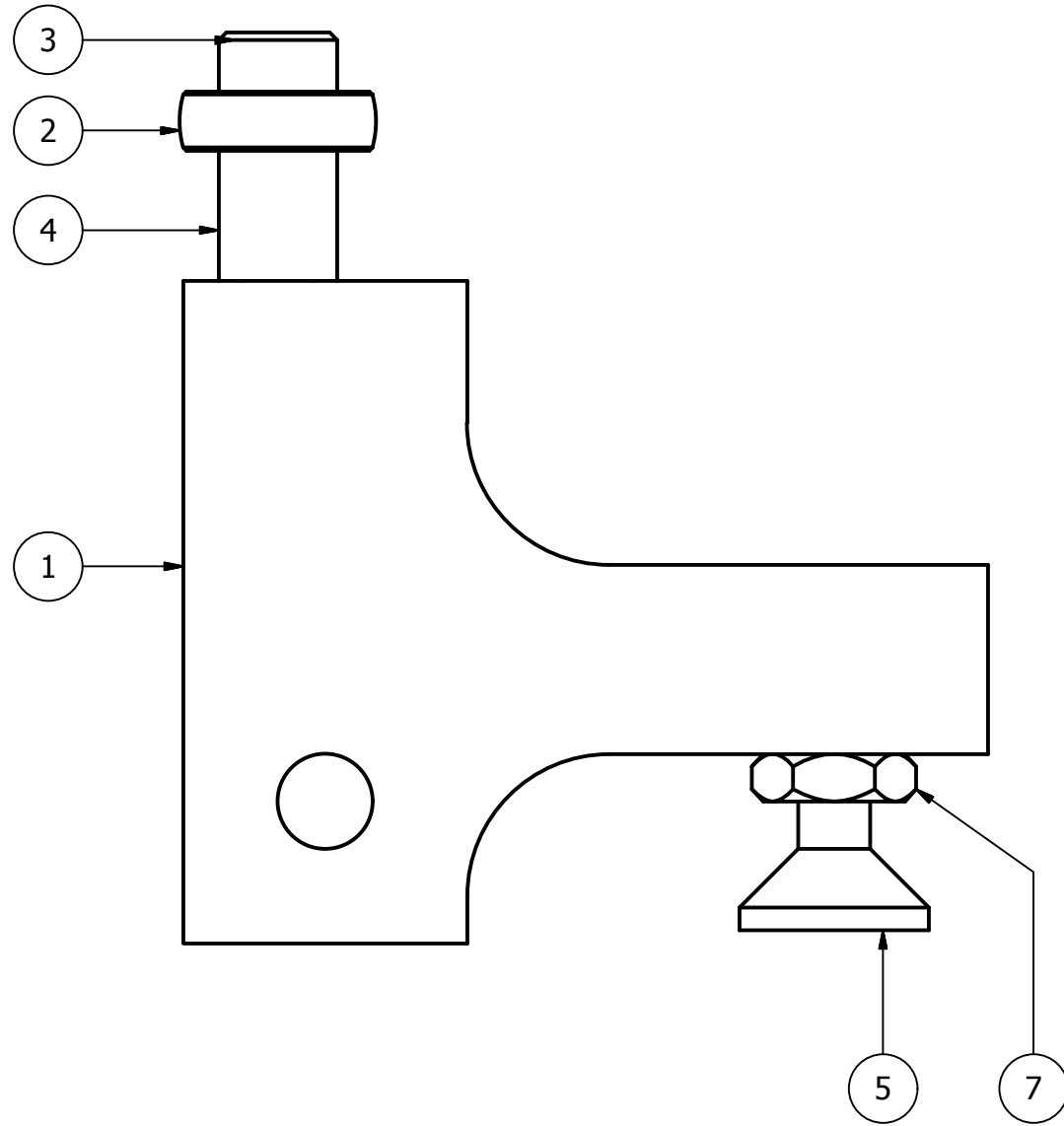

DRAWN Rob	4/21/2019	Chirico Engine Works		
CHECKED		TITLE		
QA		Cam Follower		
MFG		SIZE B	DWG NO	REV
APPROVED		Assy - Cam Follower		
		SCALE	SHEET 1 OF 1	

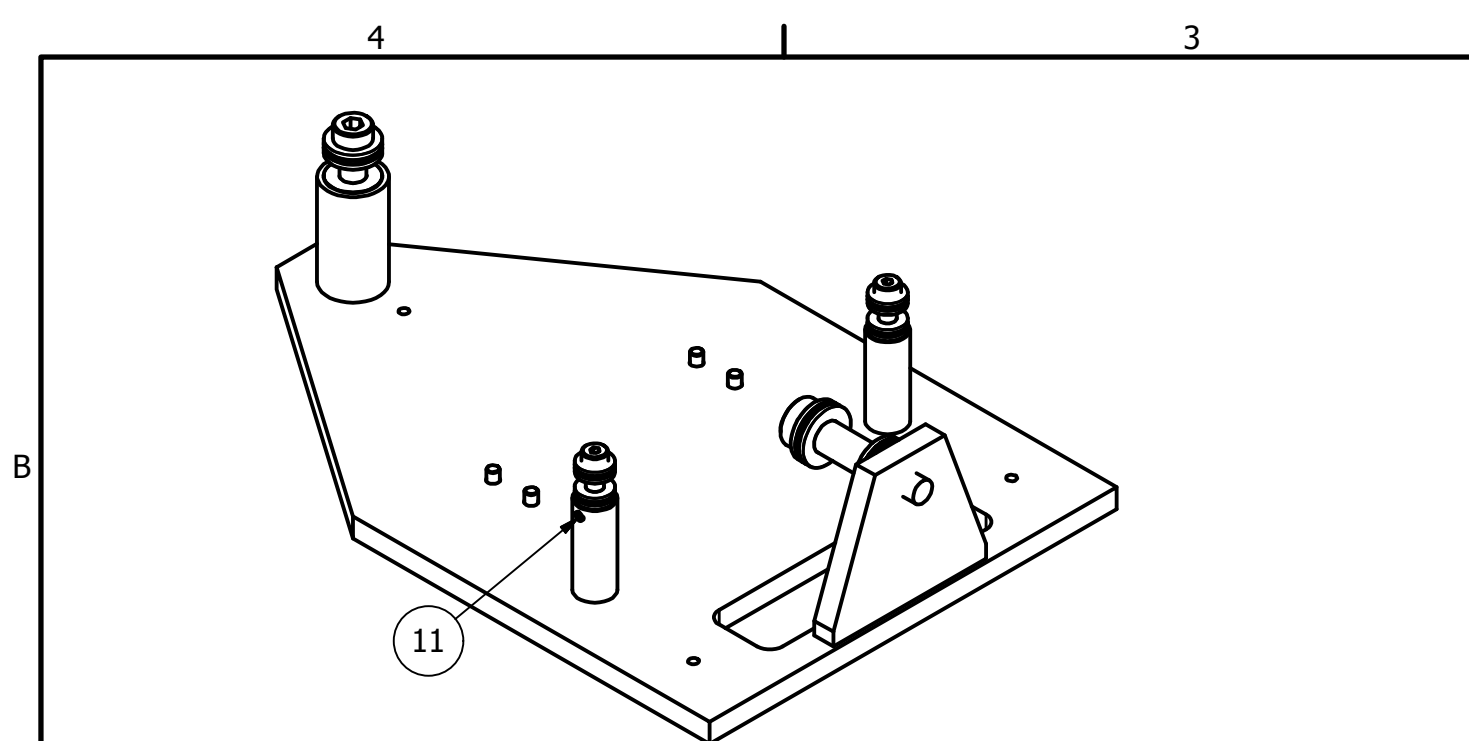

PARTS LIST			
ITEM	QTY	PART NUMBER	DESCRIPTION
1	1	Baseplate	MATERIAL: 6061 AL
2	2	Pivot Arm Base	
3	1	Post, Flywheel	Material: 6061 AL
4	1	Post, Walking Beam	
5	2	.250 dia x 0.625 lg x 10-32 thread Shoulder Screw	.125 dia x .406 lg x 4-40 thread Shoulder Screw
6	1	.375 dia x 0.875 lg x 5_16-16 thread Shoulder Screw	.125 dia x .406 lg x 4-40 thread Shoulder Screw
7	1	.500 dia x 1.500 lg x 3_8-16 thread Shoulder Screw	.125 dia x .406 lg x 4-40 thread Shoulder Screw
8	8	1106SHCS	#10-32 X 3/8" LG SHCS
9	3	1108SHCS	
10	1	2508SHCS	
11	3	0803COPS	10-32 X 1/4 CUP POINT SETSCREW
12	4	6655K130_PLASTIC THRUST BALL BEARING	
13	2	6655K170 1_2 THRUST BALL BEARING	
14	2	6655k15 3_8 Thrust Bearing	
15	3	9540K664 RUBBER BUMPER	

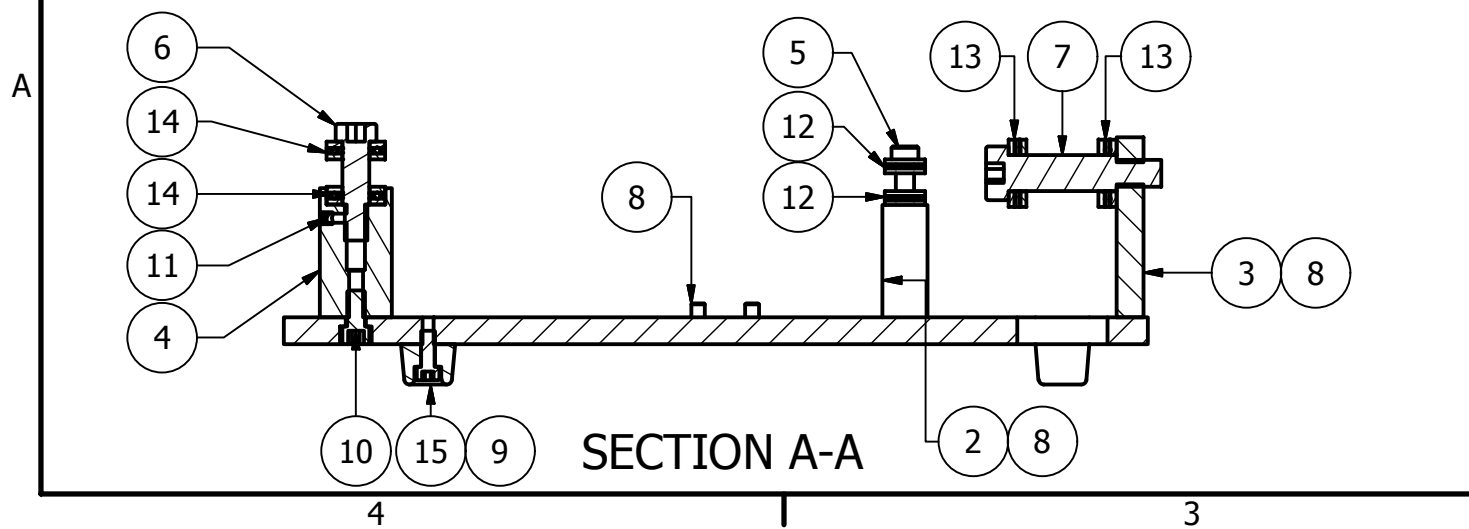
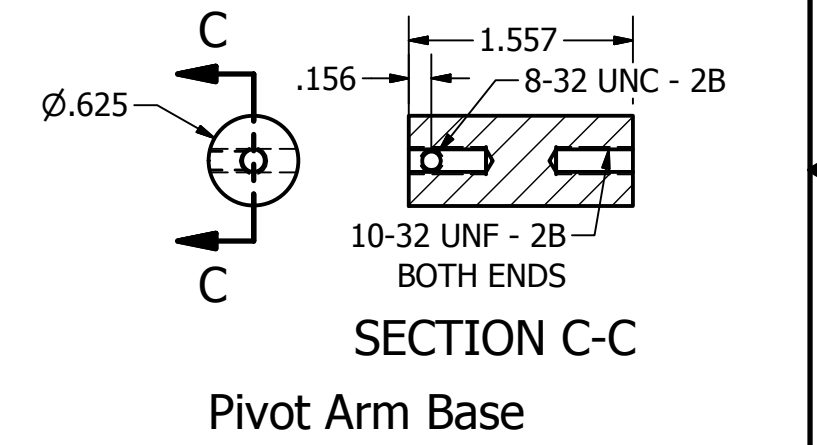
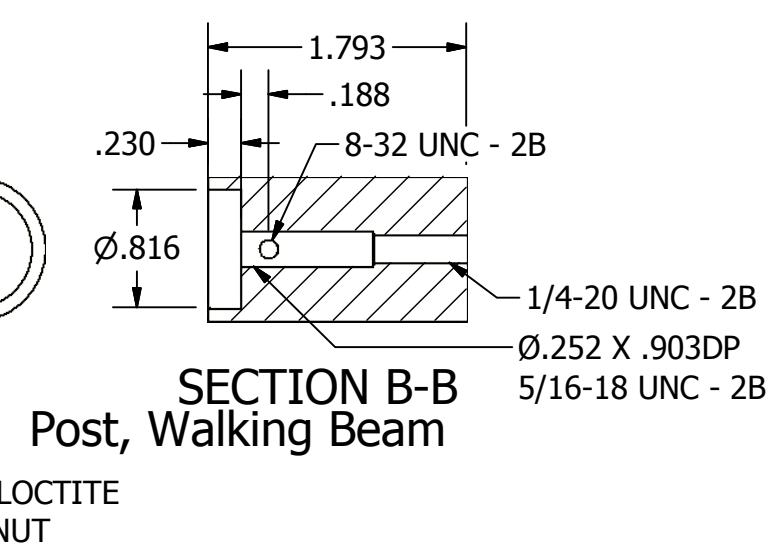
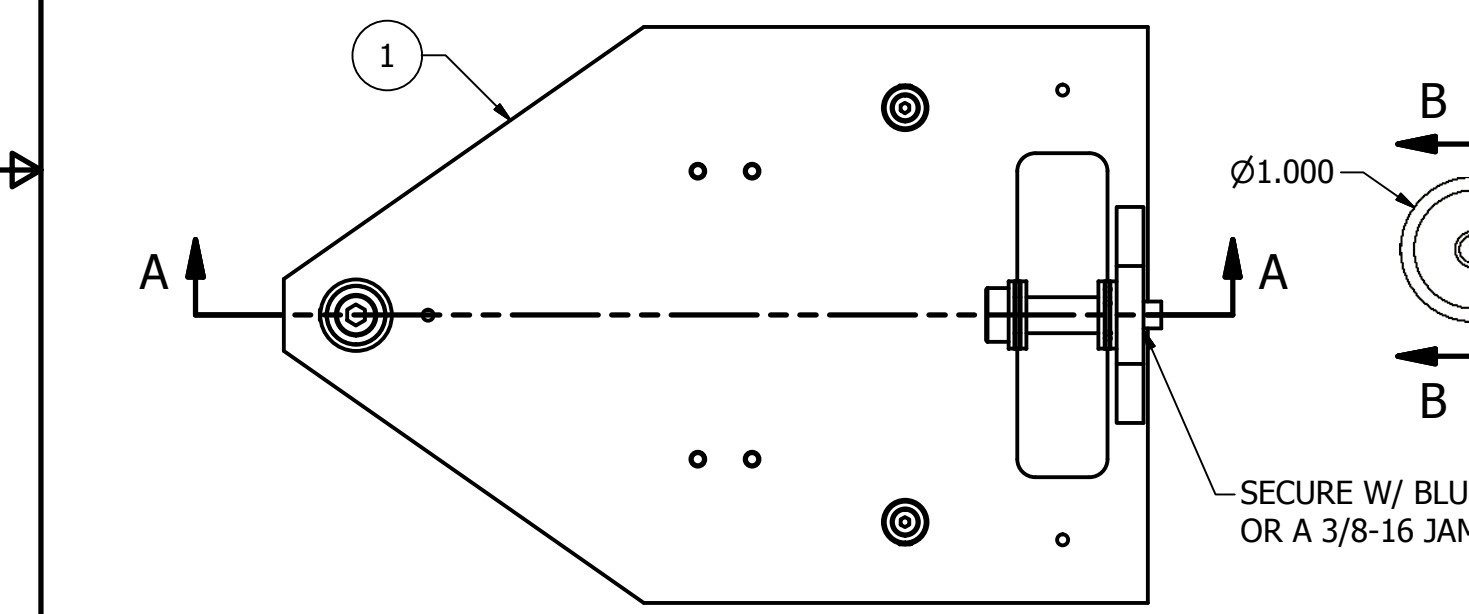

DRAWN Rob	6/15/2019	Chirico Engine Works	
CHECKED		TITLE	
QA		BASEPLATE ASSEMBLY	
MFG		SIZE B	DWG NO
APPROVED		Assy, Baseplate	
		SCALE	REV
		SHEET 1 OF 1	