

Module ( Pitch): 0.8  
 Material: Brass  
 No. Of Teeth: 30  
 Pitch Dia: 24.00 mm  
 Pressure Angle: 20.0 °

PARTS LIST			
ITEM	QTY	PART NUMBER	DESCRIPTION
1	1	Gear, Mod .8, 24 Pitch DIameter, 30 Tooth	BRASS
2	1	Valve Cam	CRS
3	1	Cam Spacer Washer	BRASS
4	1	Spring Pin - $\phi$ .094 x .625 lg	

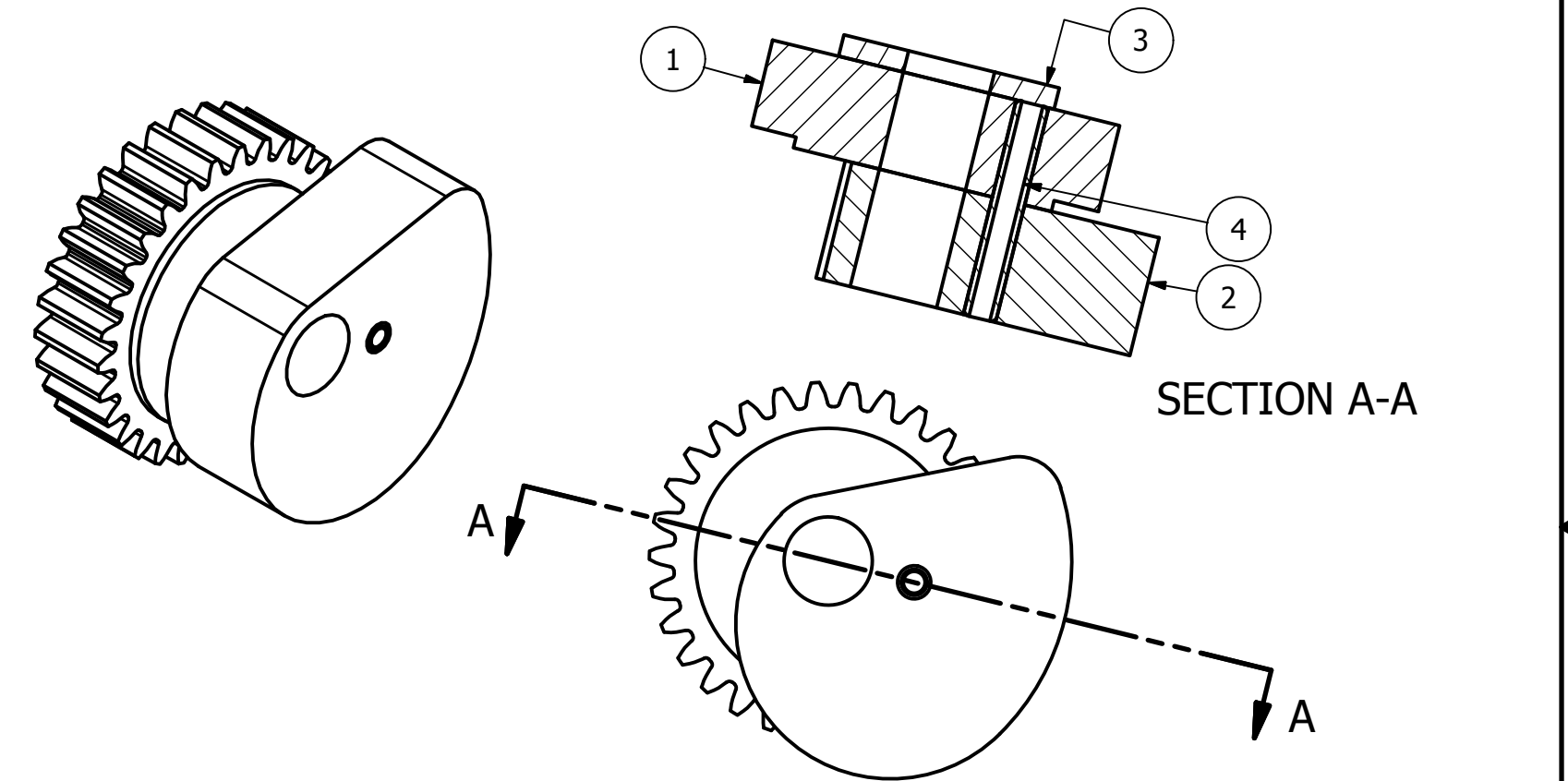

DRAWN Rob	2/1/2020	Chirico Engine Works		
CHECKED				
QA		TITLE		
MFG				
APPROVED				
		SIZE B	DWG NO Assy - Cam	REV 2
		SCALE	SHEET 1 OF 2	

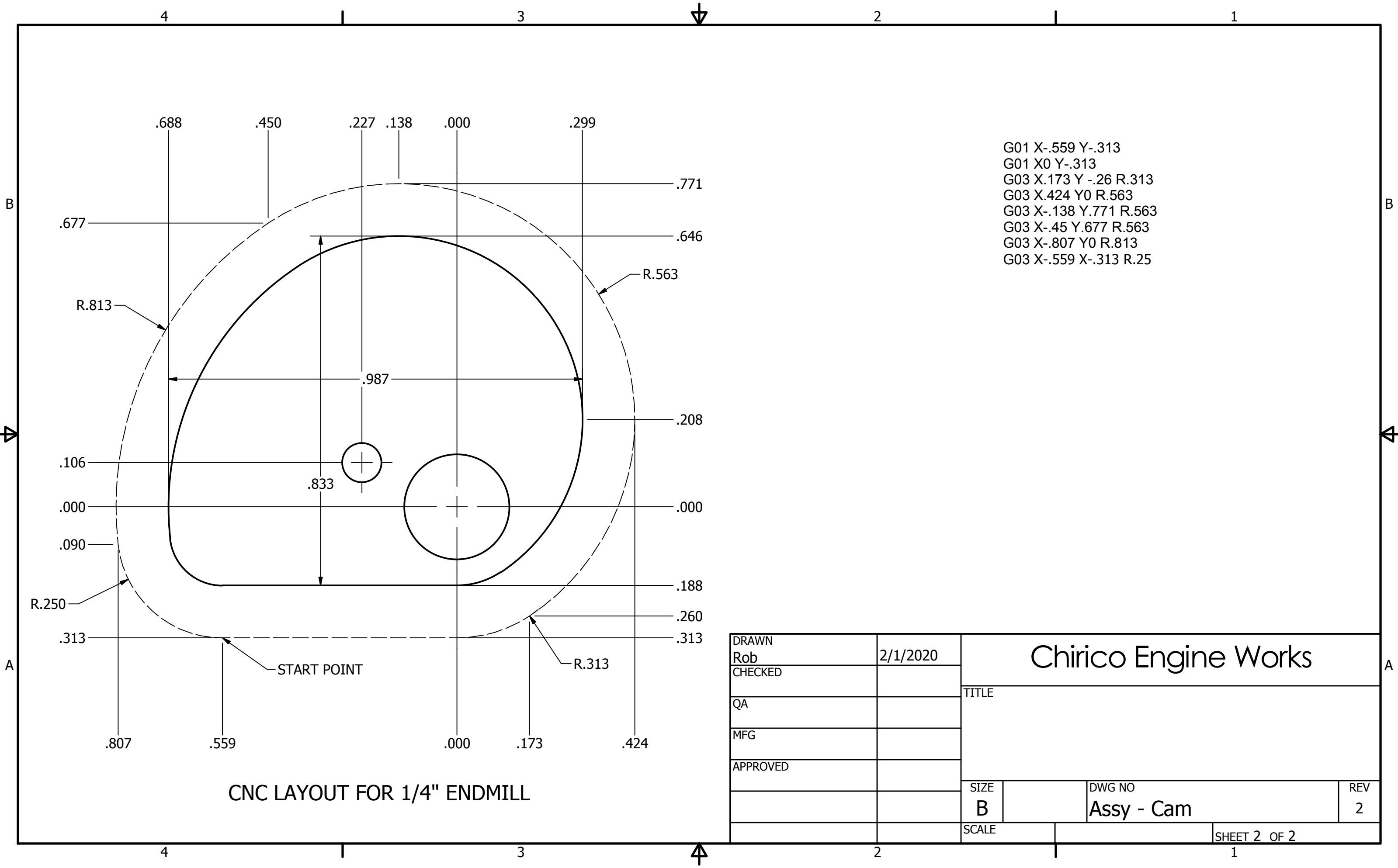

CNC LAYOUT FOR 1/4" ENDMILL

DRAWN Rob	2/1/2020	Chirico Engine Works		
CHECKED				
QA		TITLE		
MFG				
APPROVED				
		SIZE <b>B</b>	DWG NO <b>Assy - Cam</b>	REV <b>2</b>
		SCALE		SHEET 2 OF 2