

PARTS LIST			
ITEM	QTY	PART NUMBER	DESCRIPTION
1	1	Gear, Mod .8, 15 Tooth, 12mm PD	BRASS
2	1	Flywheel Shaft 02	BRASS
3	1	Gear, Mod .8, 24 Pitch DIiameter, 30 Tooth	BRASS

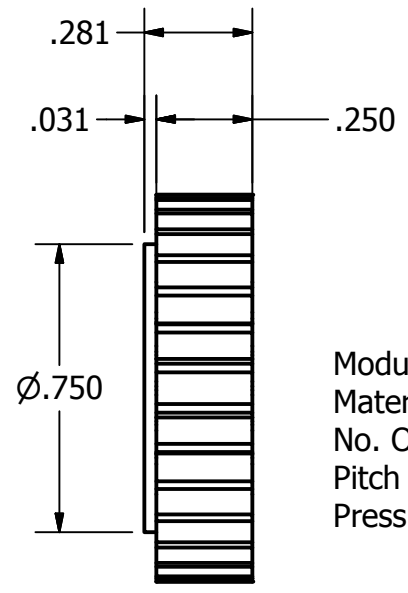

Module (Pitch): 0.8
 Material:Brass
 No. Of Teeth:30
 Pitch Dia: 24.00 mm
 Pressure Angle: 20.0 °

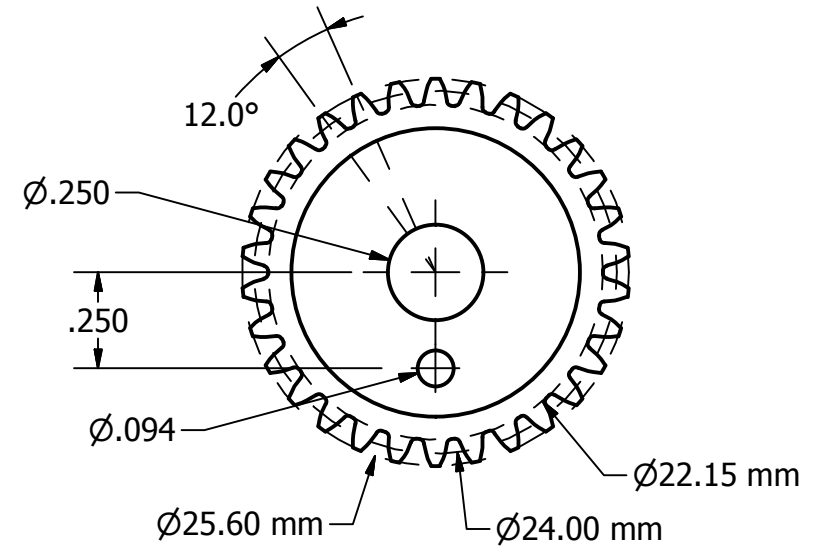
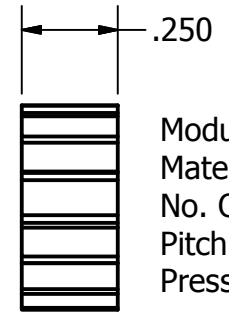
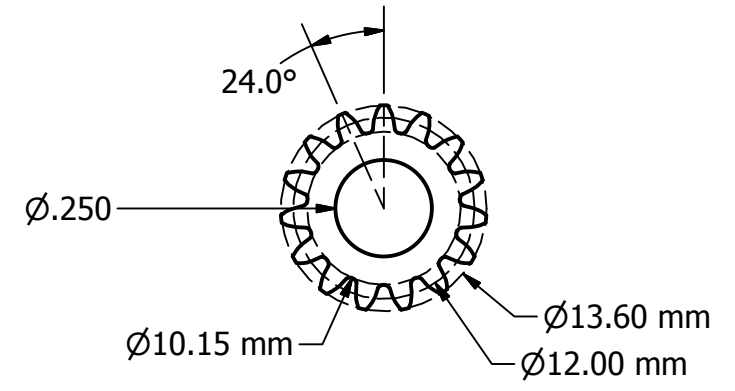

Module (Pitch): 0.8
 Material:Brass
 No. Of Teeth:15
 Pitch Dia: 12.00 mm
 Pressure Angle: 20.0 °

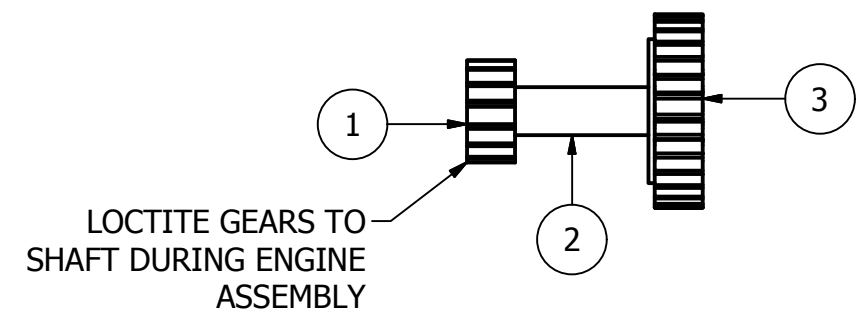
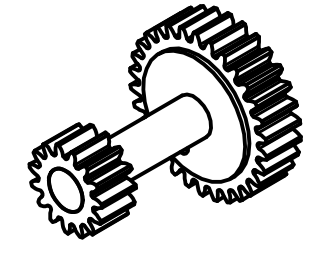
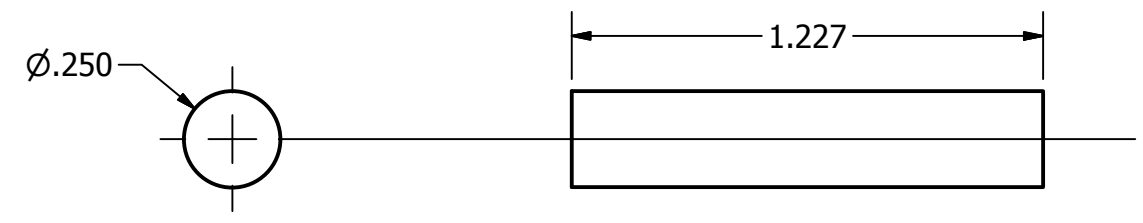

DRAWN Rob	2/1/2020	Chirico Engine Works		
CHECKED				
QA		TITLE		
MFG				
APPROVED				
		SIZE B	DWG NO Assy - Camshaft	REV
		SCALE	SHEET 1 OF 1	