

PARTS LIST			
ITEM	QTY	PART NUMBER	DESCRIPTION
1	1	Valve	BRASS
2	1	Valve Rod Joint 01	BRASS
3	1	Valve Roller	Material: Brass
5	1	Pin, Cam Roller	Material: Brass
6	1	1108COPS	10-32 X 1/2 CUP POINT SETSCREW
8	1	Collar, Spring Compression	BRASS
9	2	0803COPS	10-32 X 1/4 CUP POINT SETSCREW

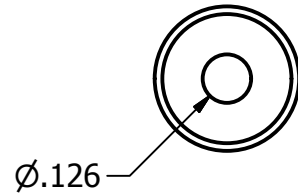
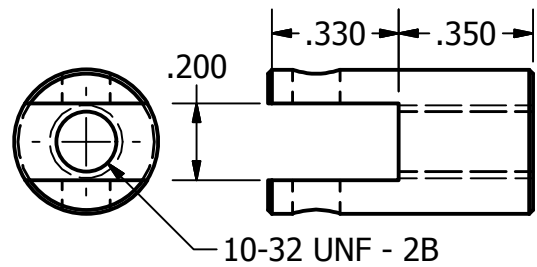
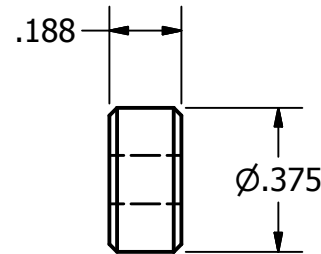
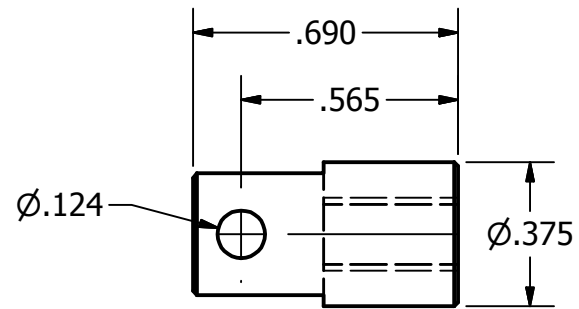
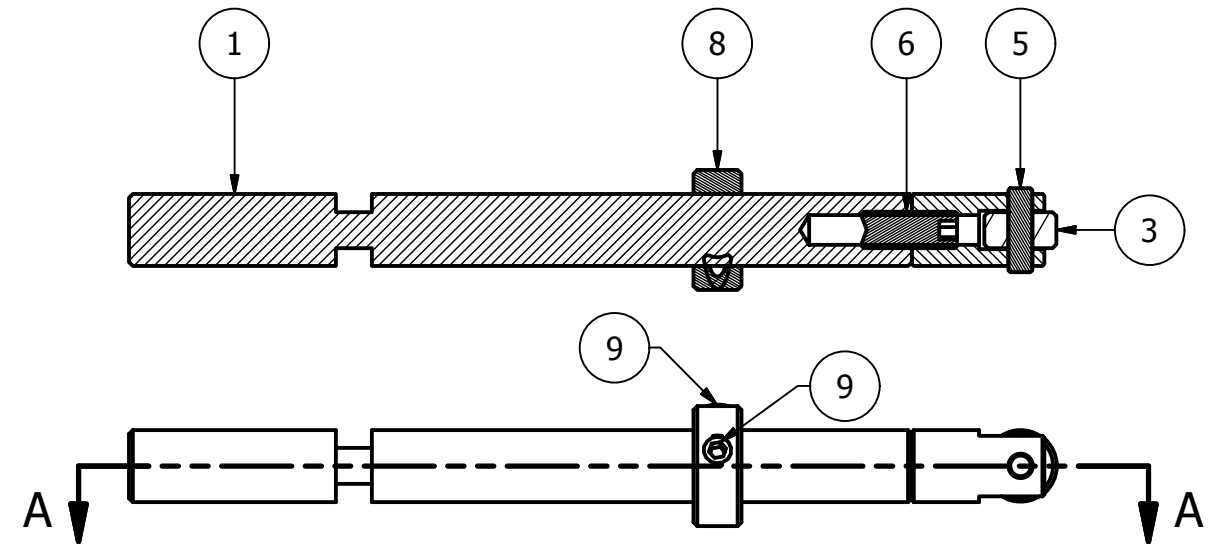
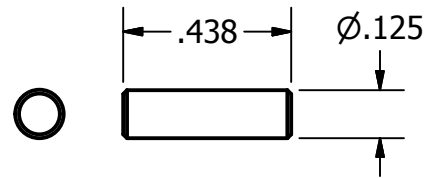
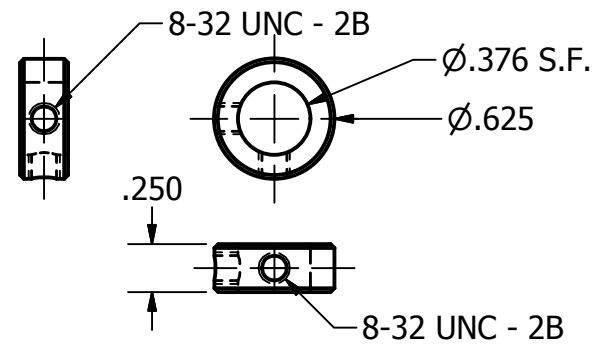

DRAWN Rob	2/1/2020	Chirico Engine Works		
CHECKED		TITLE		
QA		VALVE ASSEMBLY		
MFG		SIZE B	DWG NO Assy, Valve	REV 2
APPROVED		SCALE	SHEET 1 OF 1	