

8

7

6

5

4

3

2

1

REVISIONS				
REV	ZONE	DESCRIPTION	DATE	APPRV.
-	-	-	-	-

### GENERAL NOTES

- SCALE ALL NON-CRITICAL DIMENSIONS NOT SHOWN USING ±.03 TOLERANCE.
- SCREW AND DOWEL PER STANDARD SHOP PRACTICE.
- SUBSTITUTION OF PARTS AND MATERIALS PER STANDARD SHOP PRACTICE PERMISSIBLE.

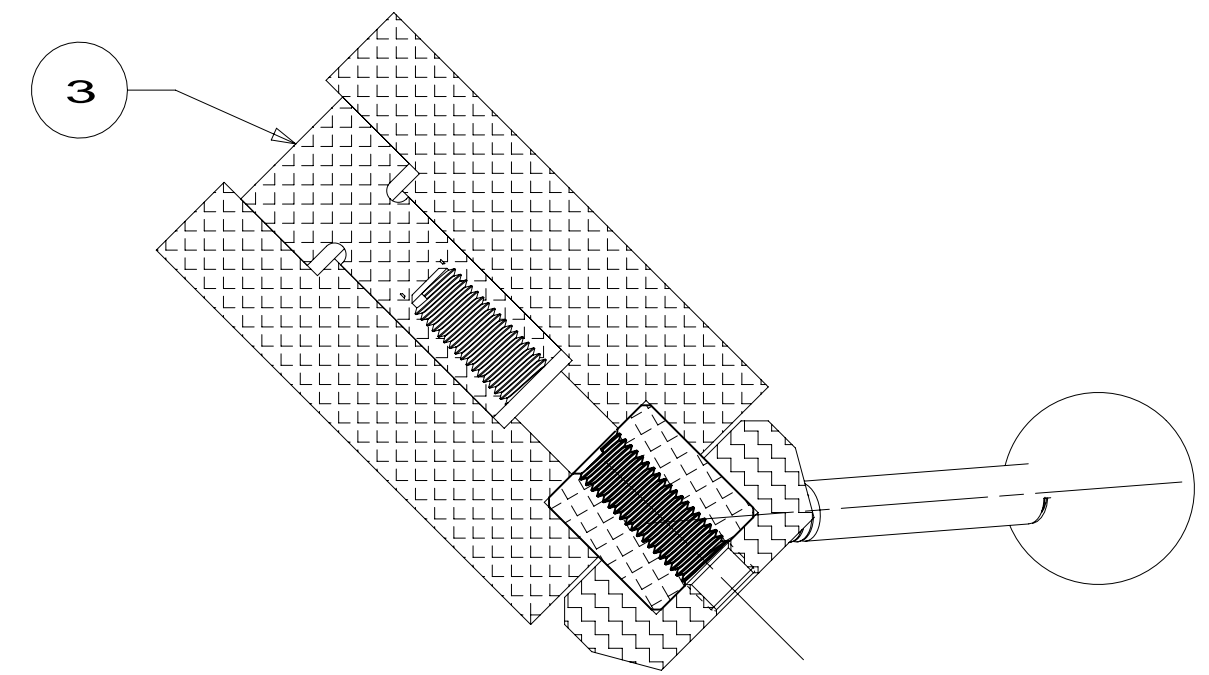

SECTION AK-AK

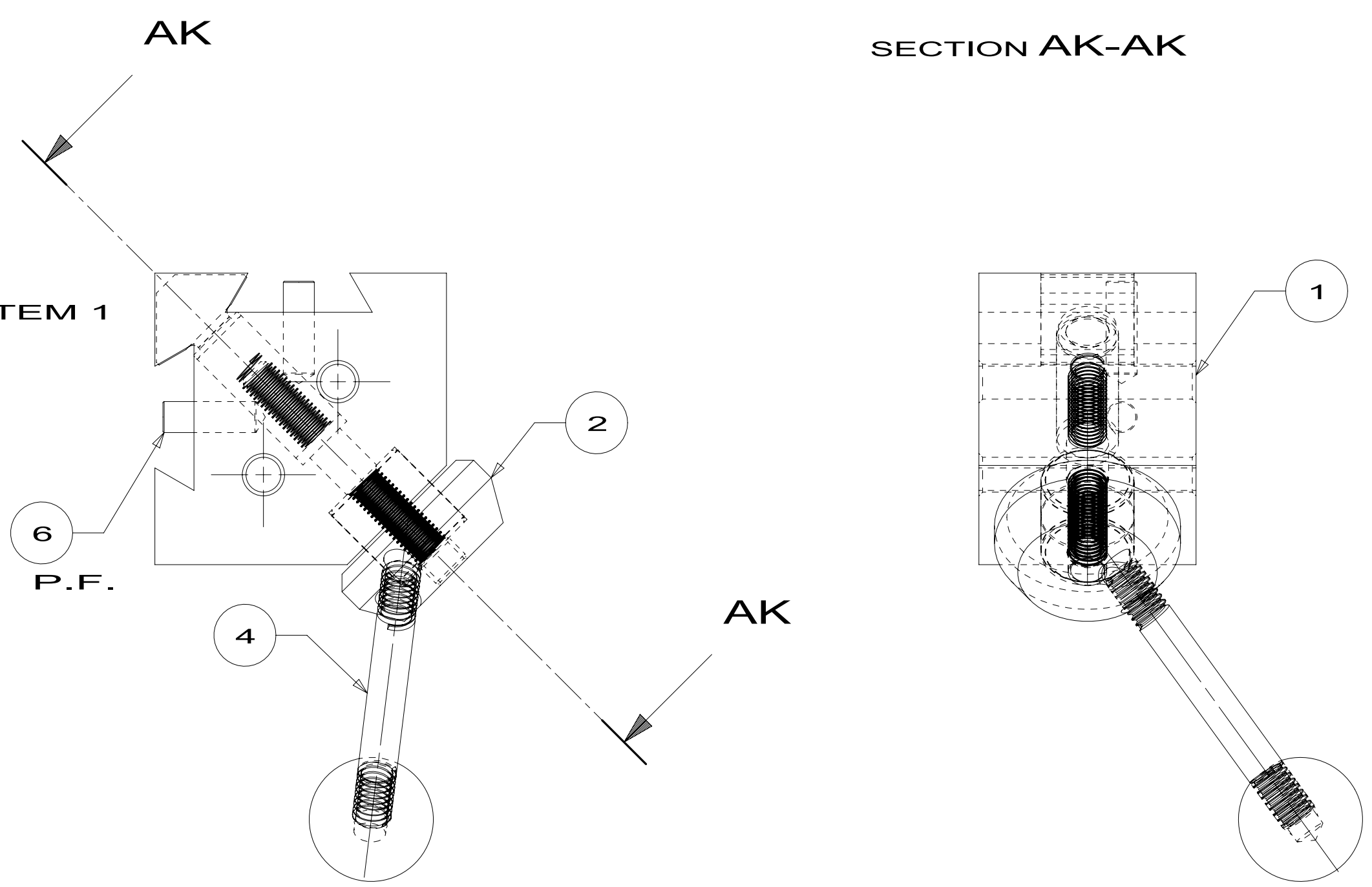

S.F. WITH ITEM 1

P.F.

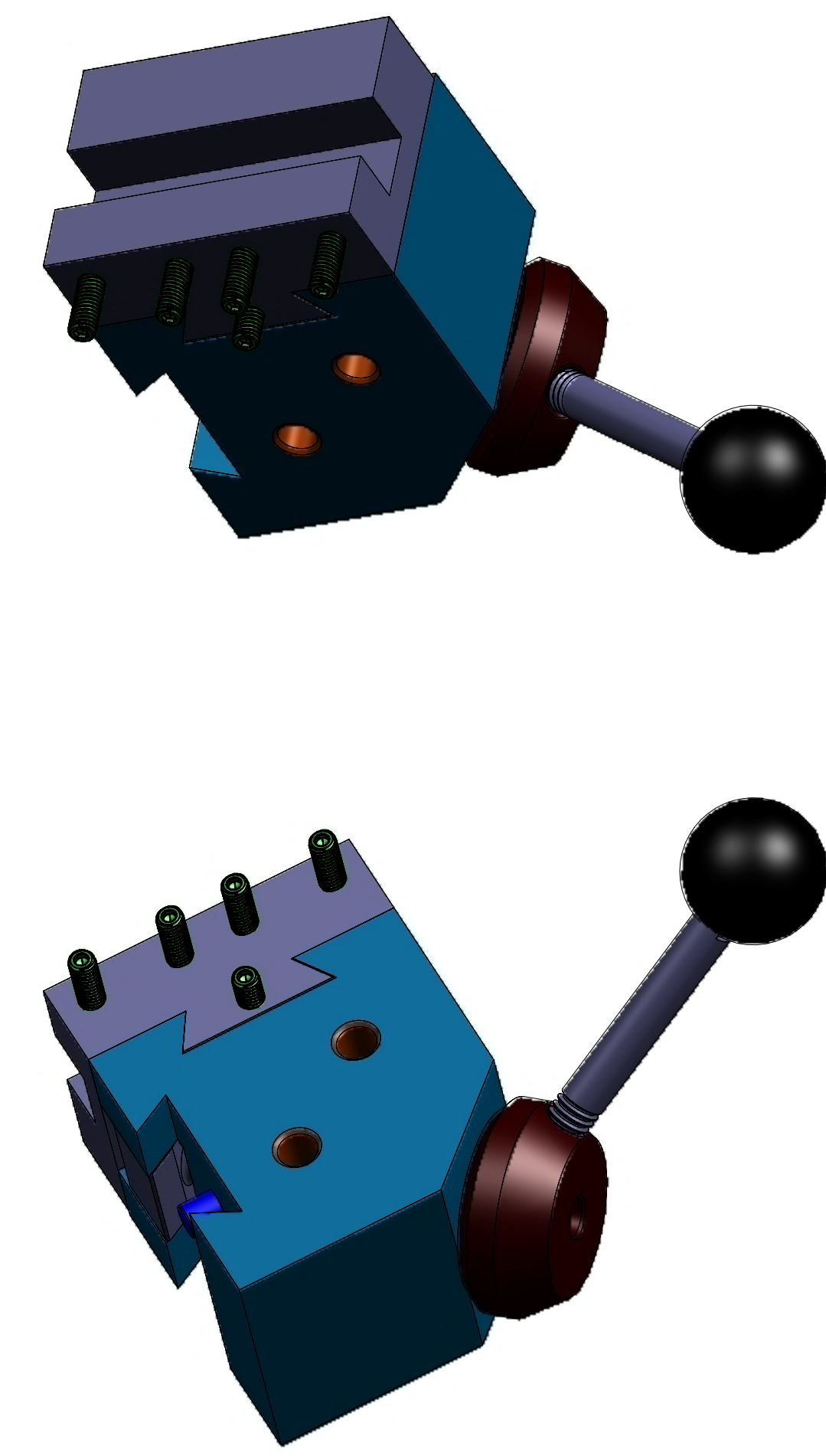
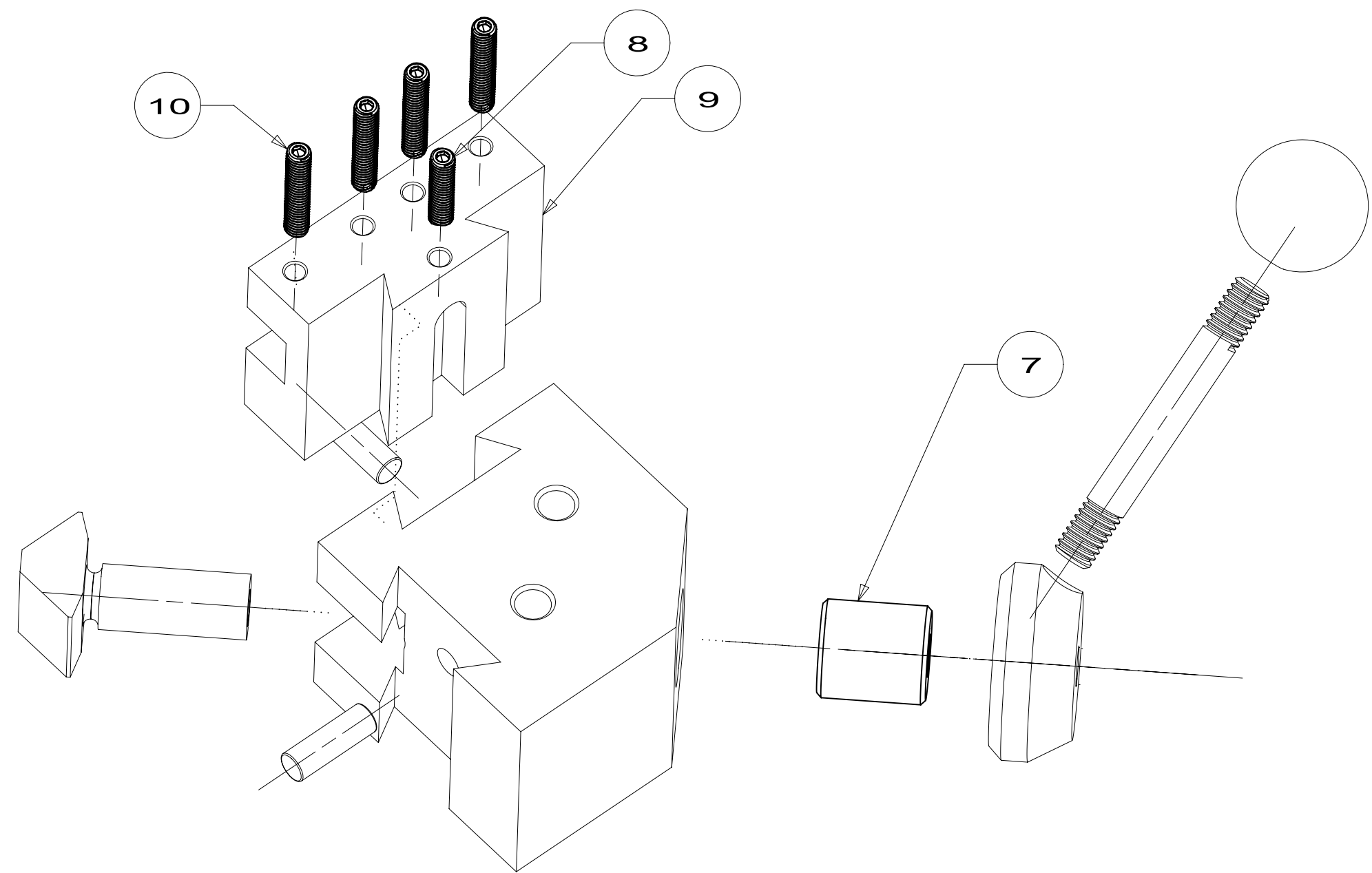
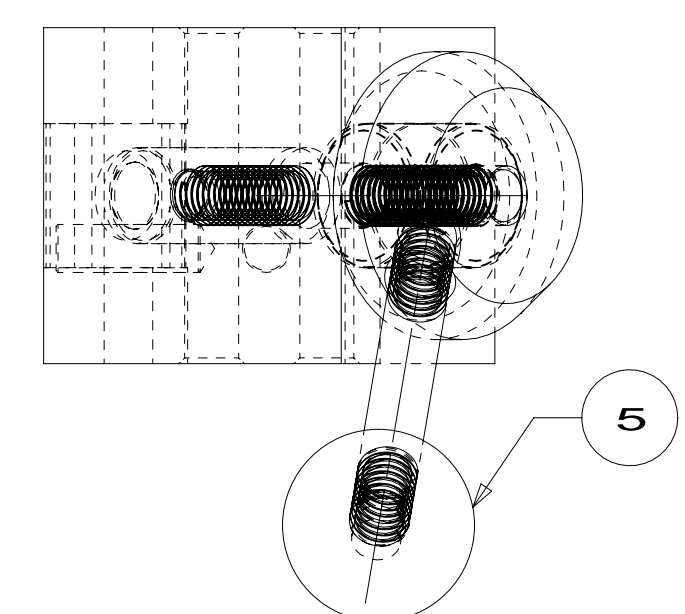

MASTER MODEL FILE(S):  
o125e6087\_--\_dw.prt

THIS IS A UGII CAD PRODUCED DRAWING.  
ALL REVISIONS SHOULD BE CAD GENERATED.

QUANTITY	ITEM	DESCRIPTION	MATERIAL AND STOCK SIZE	REMARKS
4	10	SET SCREW	10-32 X 1.0	
1	9	TOOL HOLDER	1.0 X 1.7 X 2.35 CRS	
1	8	SET SCREW	10-32 X 1.0	
1	7	LOCKING NUT	.750 Ø X .825 CRS	
2	6	HIEGHT ADJUST PIN	1/4 Ø X 3/4 CRS	
1	5	HANDLE KNOB	5/16-18 X 1.0 Ø ALUMINUM	
1	4	HANDLE STUD	5/16-18 X 2.5	
1	3	CLAMP STUD	1 5/16 Ø X 1.75 TOOL STEEL	HT 45-50 Rc
1	2	HANDLE BODY	1.5 Ø X .625 ALUMINUM	
1	1	MAIN BODY	1.75 X 2.35 X 2.35 CRS	

PARTS LIST				
QUANTITY	ITEM	DESCRIPTION	MATERIAL AND STOCK SIZE	REMARKS
ALL DIMENSIONS IN INCHES UNLESS OTHERWISE NOTED.				
TOLERANCES UNLESS OTHERWISE NOTED:				
ANGULAR	LINEAR			
± 0°30'	.X = ±.03			
	.XX = ±.010			
	.XXX = ±.005			
	.XXXX = ±.0005			
INTERPRET DRAWING IN ACCORDANCE WITH ANSI/ASME Y14.5-1994				
BREAK ALL EDGES .015 - .030				
SCALE: 1:1		DESIGNED BY, DATE G. DOCKTER 1.14.1980		
CHECKED BY, DATE G. DOCKTER		APPROVED ME, DATE N/A		
APPROVED NC, DATE N/A		APPROVED QA, DATE N/A		
SIZE	CAGE CODE	FILE NUMBER	REV	
D	21210	QCTP6087	-	
SHEET 1 OF 4				

### QUICK CHANGE TOOL POST

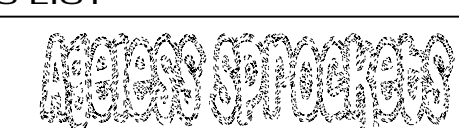

8

7

6

5

4

3

2

1

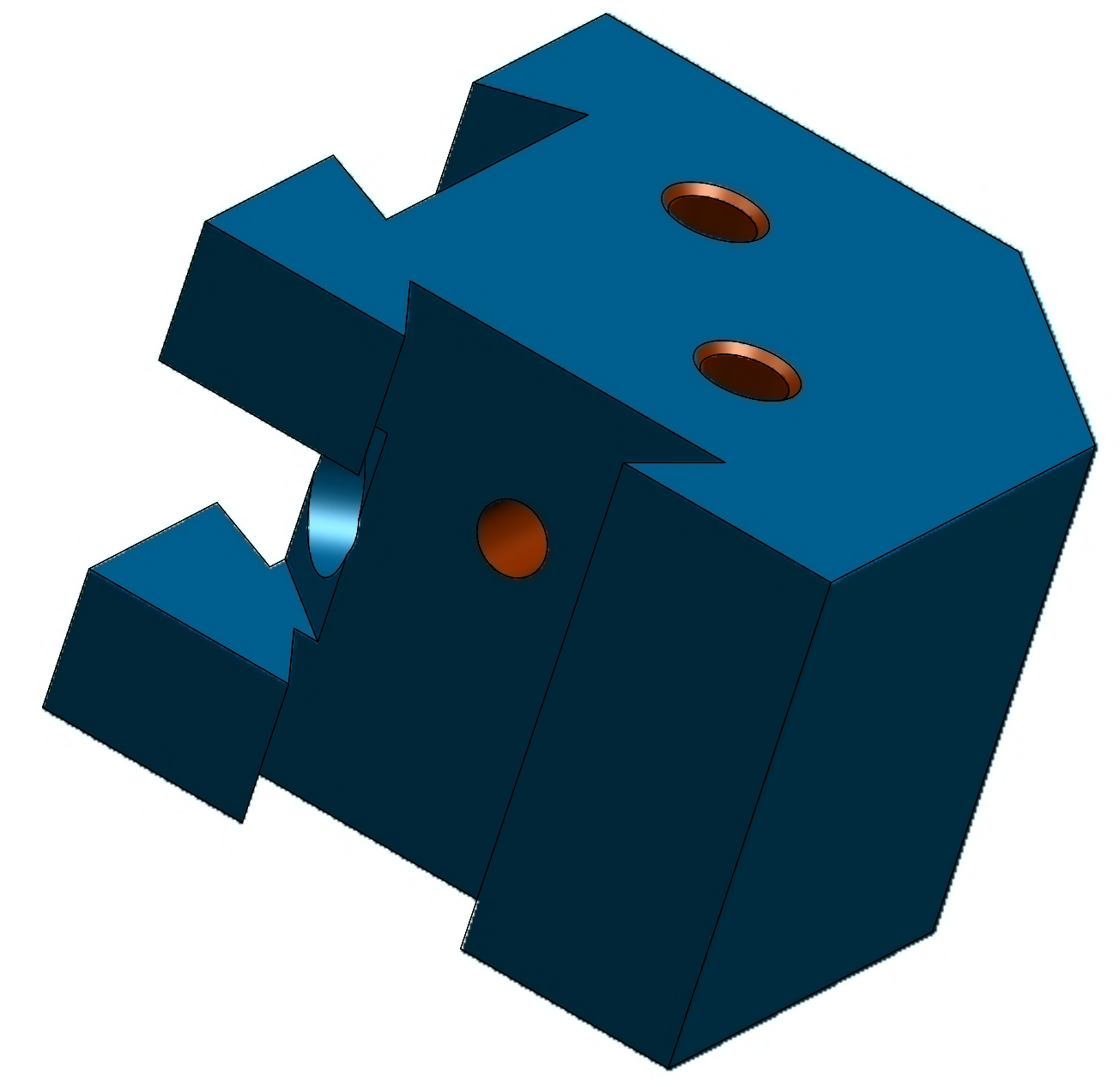
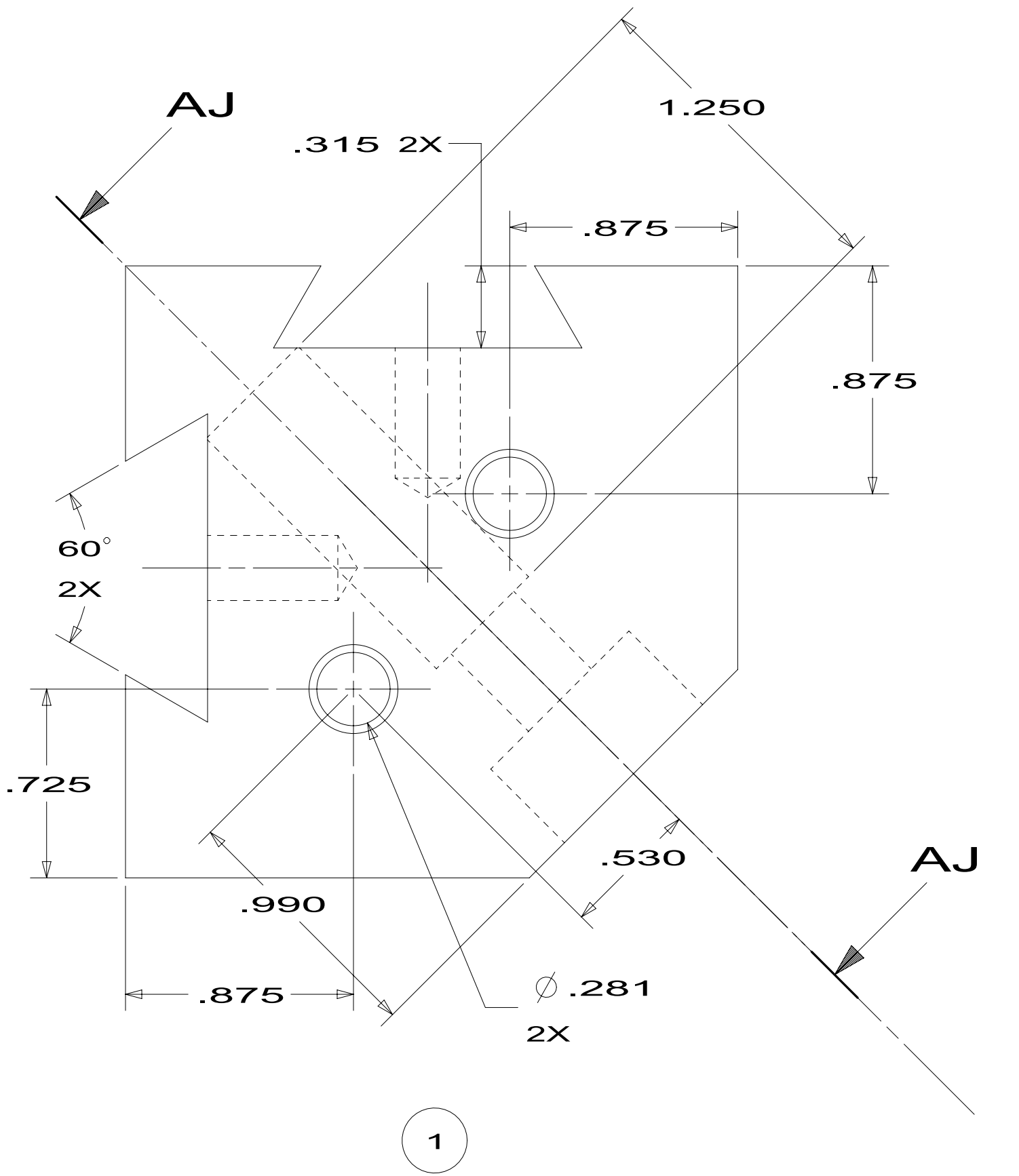
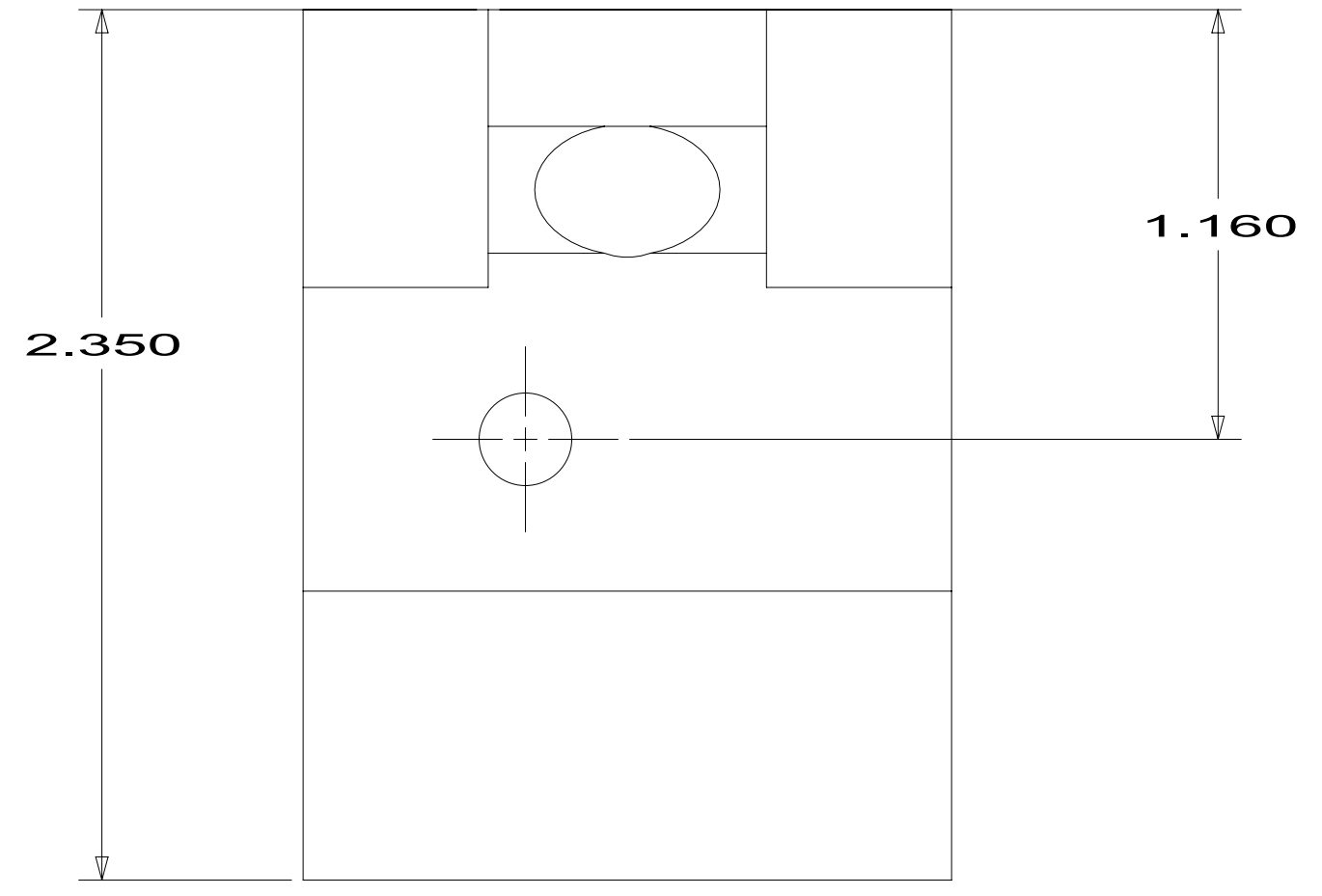
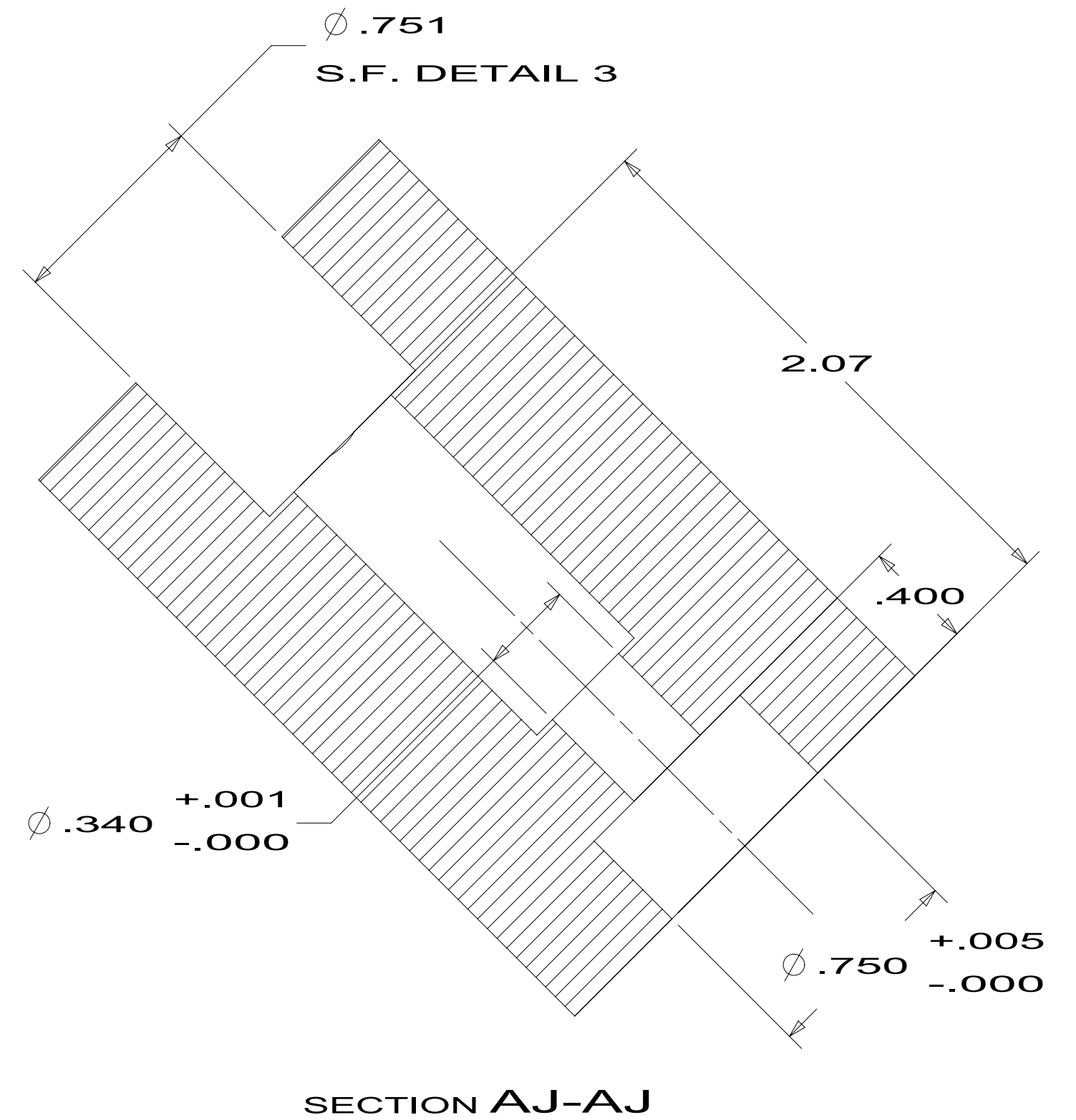
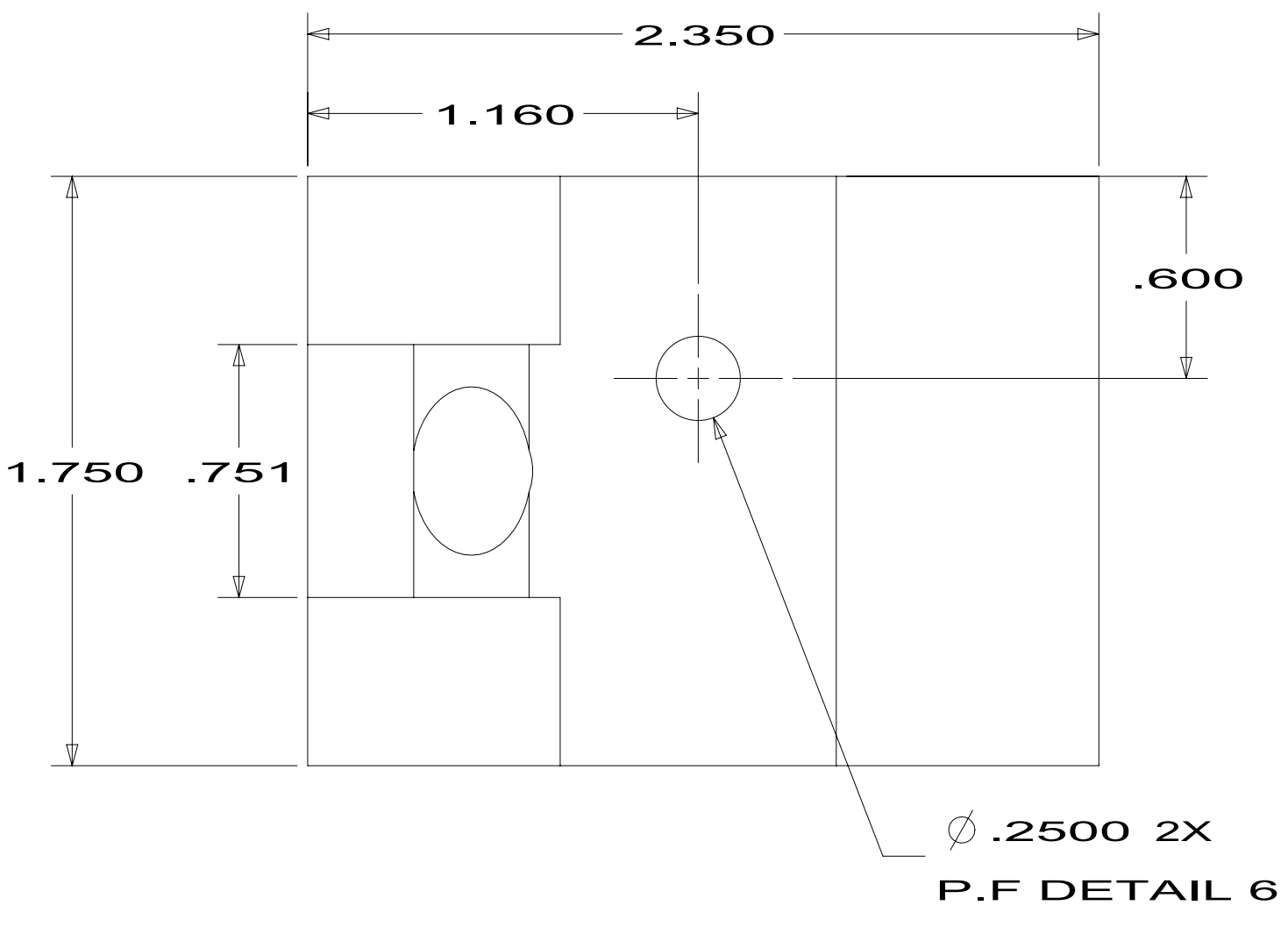
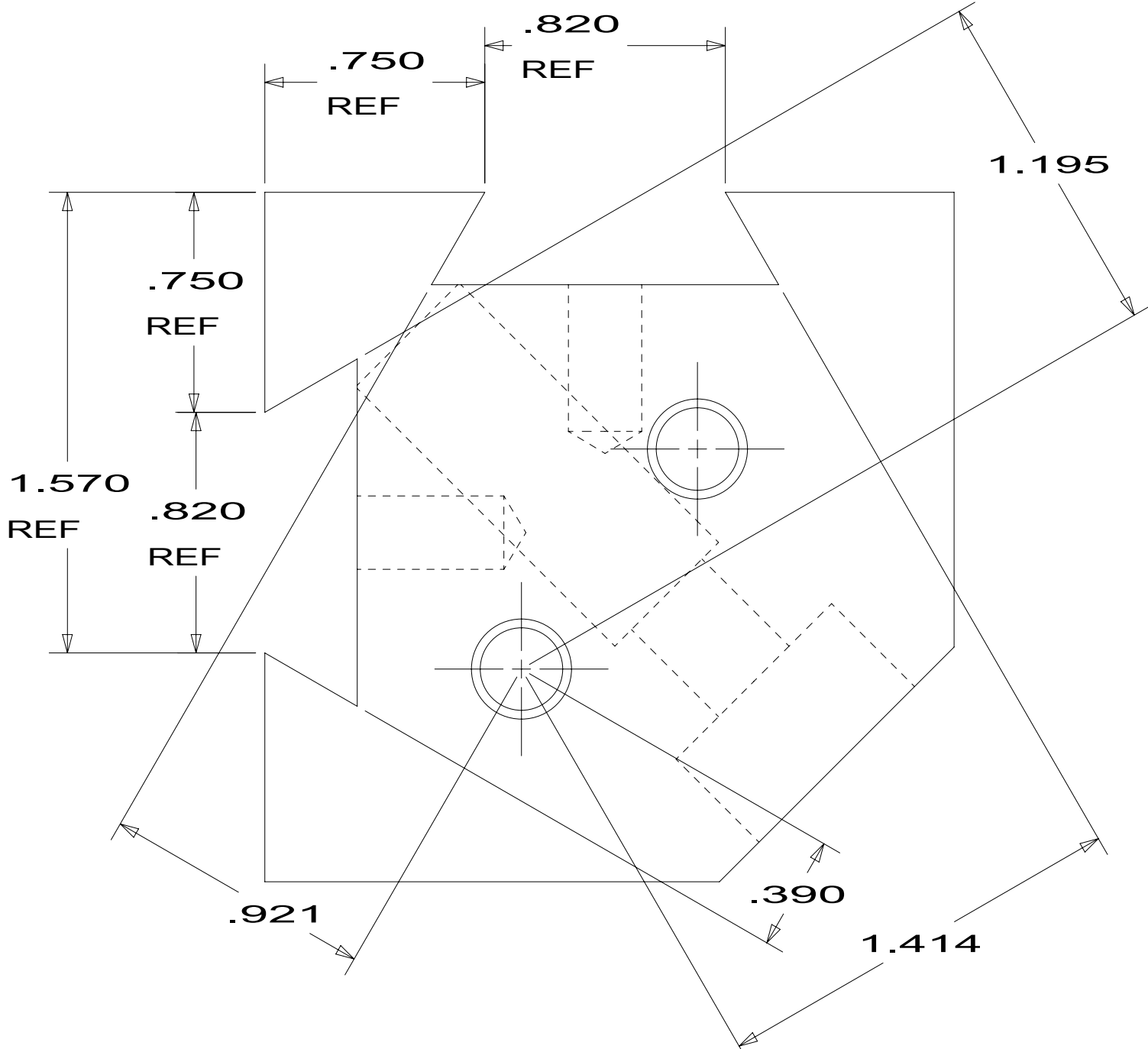
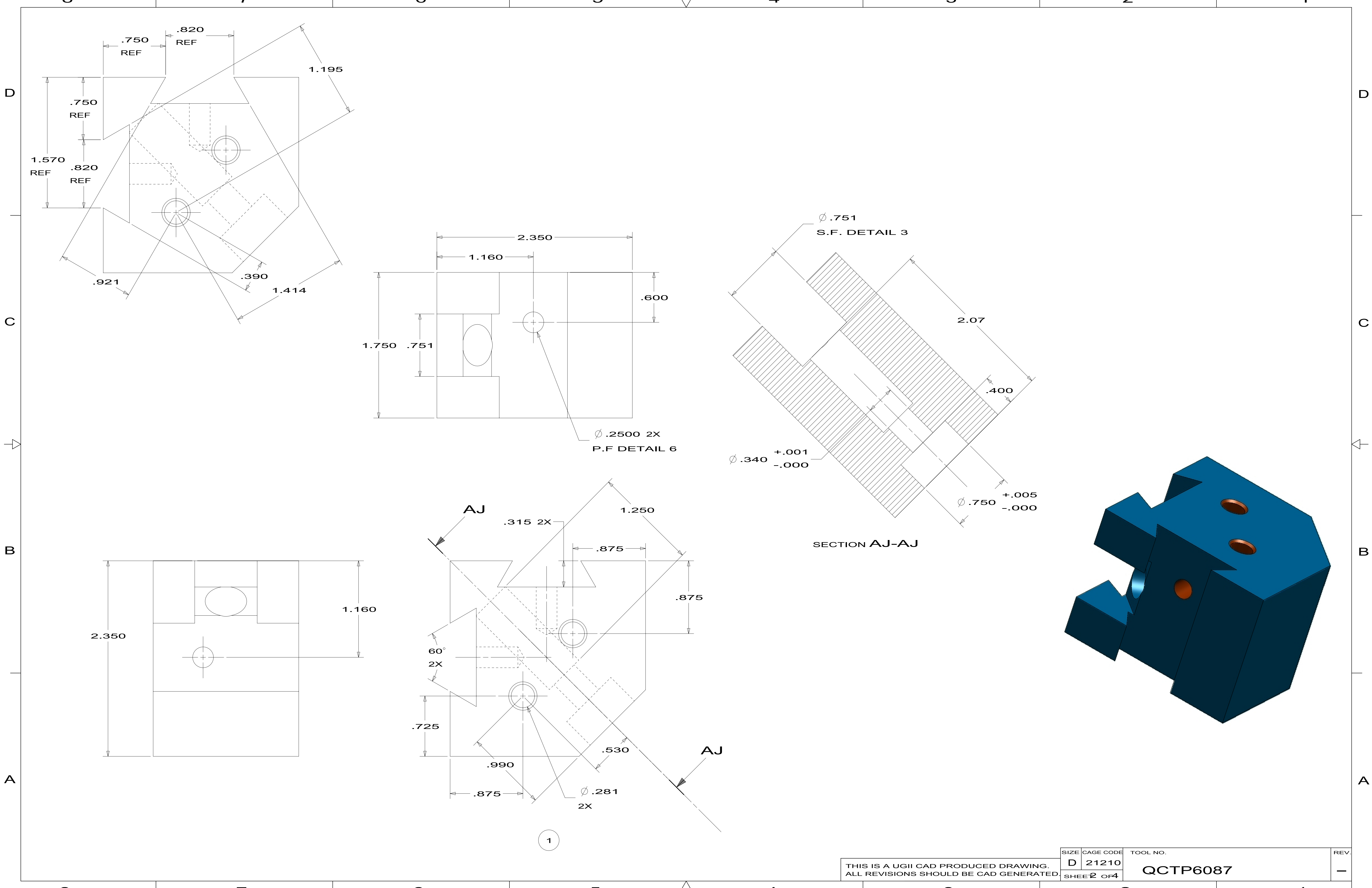

THIS IS A UGII CAD PRODUCED DRAWING. ALL REVISIONS SHOULD BE CAD GENERATED.		SIZE D	CAGE CODE 21210	TOOL NO. QCTP6087	REV. -
			SHEET 2 OF 4		

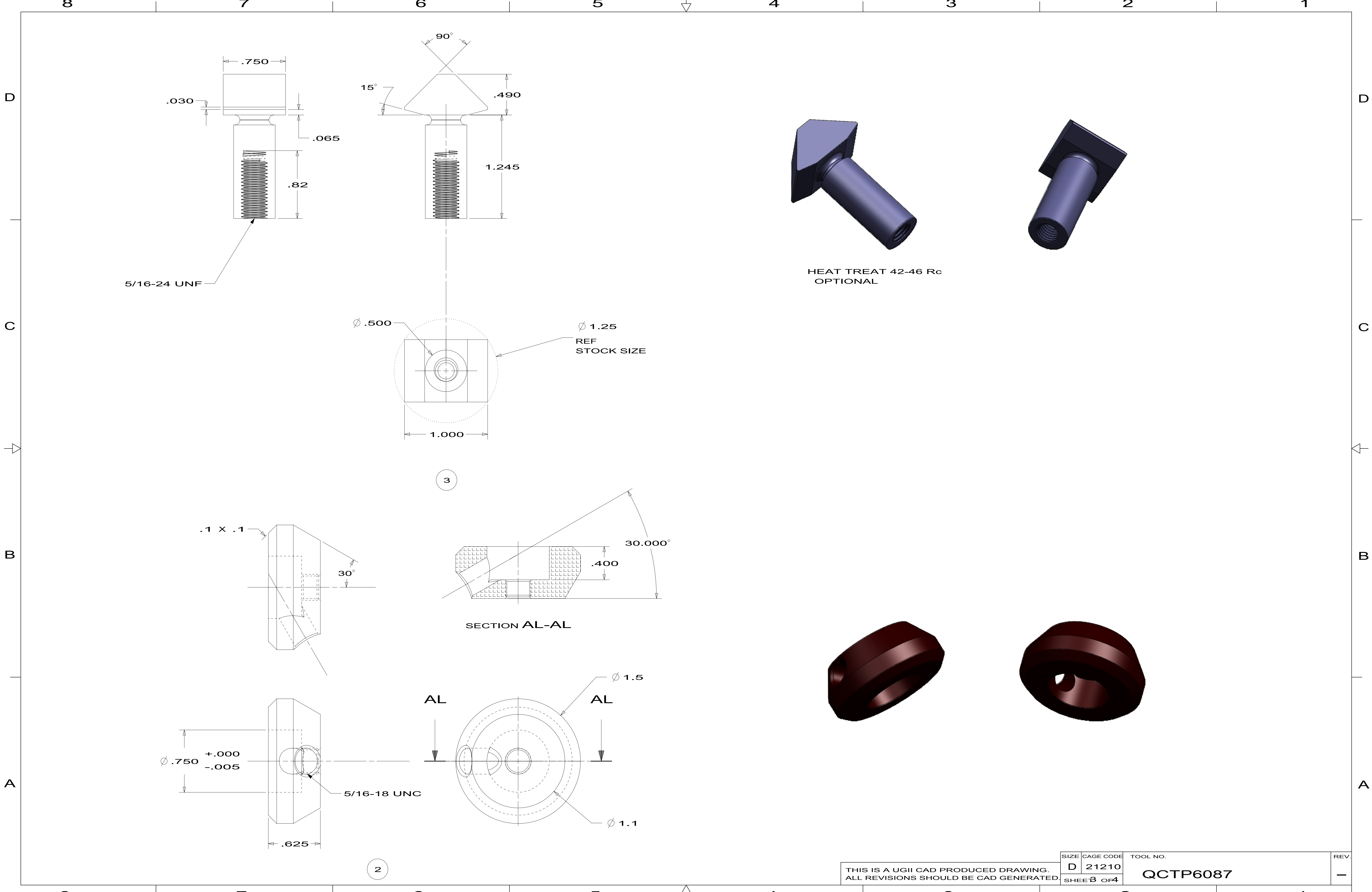

5/16-24 UNF

HEAT TREAT 42-46 Rc  
OPTIONAL

SECTION AL-AL

THIS IS A UGII CAD PRODUCED DRAWING.  
ALL REVISIONS SHOULD BE CAD GENERATED.

SIZE	CAGE CODE	TOOL NO.	REV.
D	21210	QCTP6087	-
SHEET 3 OF 4			



8

7

6

5

4

3

2

1

D

D

C

C

B

B

A

A

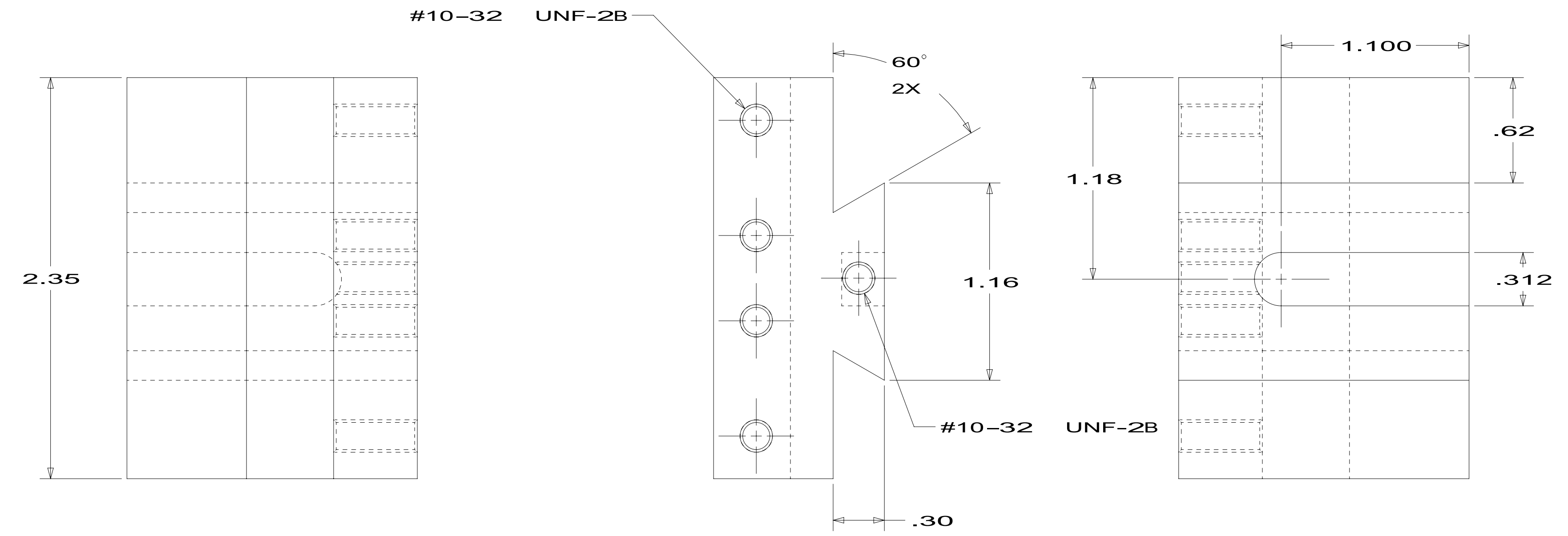
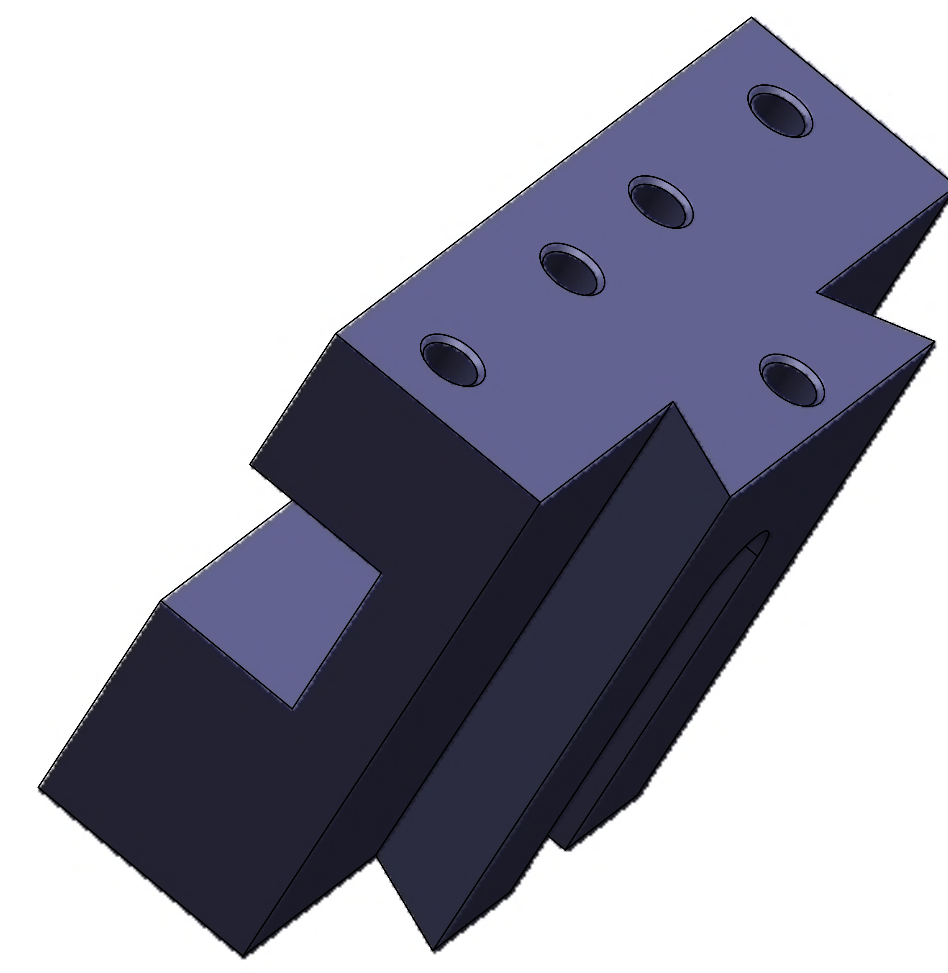
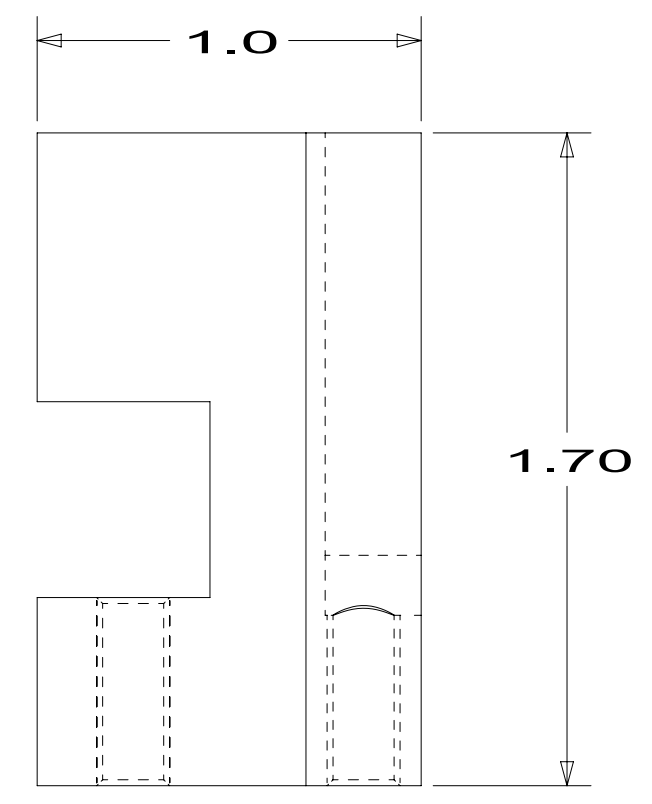

9

THIS IS A UGII CAD PRODUCED DRAWING. ALL REVISIONS SHOULD BE CAD GENERATED.		SIZE D	CAGE CODE 21210	TOOL NO. QCTP6087	REV. -
			SHEET 4 OF 4		

8

7

6

5

4

3

2

1