

Inner (Counterbore part) is 1 3/8" ID which is what the bore will be.  
'D' shape c'bore will be in a separate piece, as will the Exhaust Boss & Mounting Boss's.

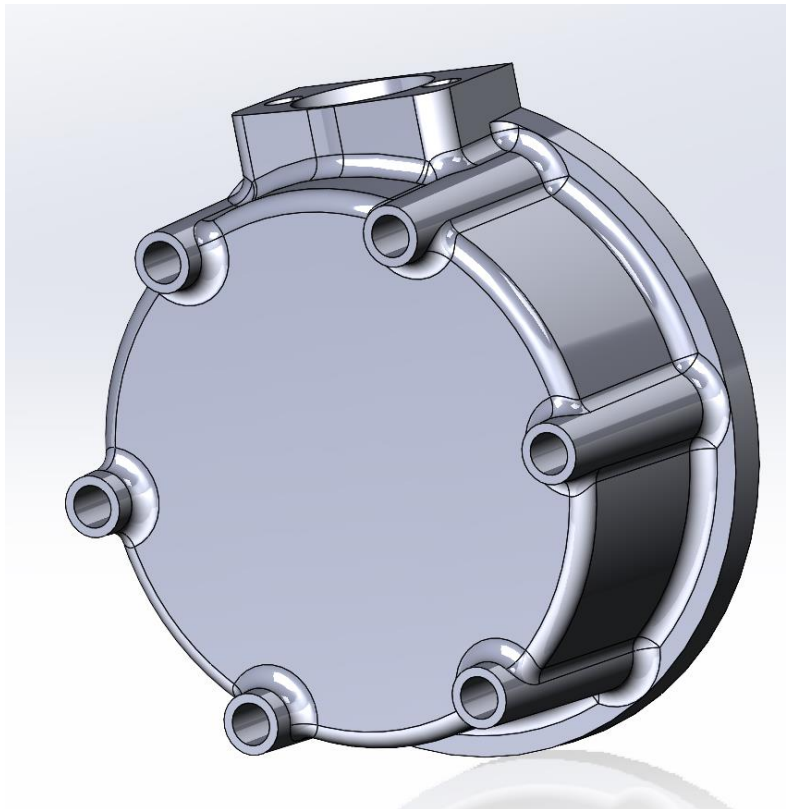

Outside Rim will be 2" Dia. (As currently shown, in practice may be smaller as at 2" it gives a 5/16" wide rim.)