

Motor Mount

Fixed Mounting Plate

mild steel

Weld to end of main tube assembly
(centered along and flush to edge).

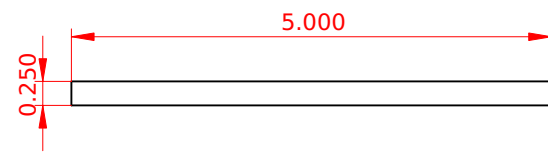
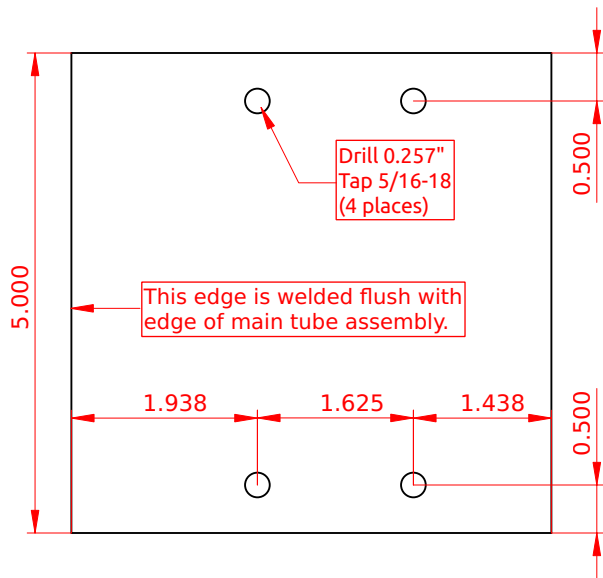

Adjustable Mount

mild steel weldment

Adjust configuration and dimensions to suit specific treadmill motor used.

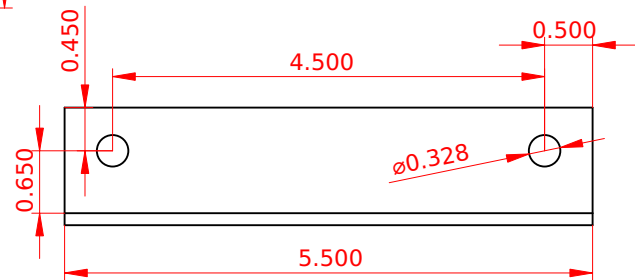
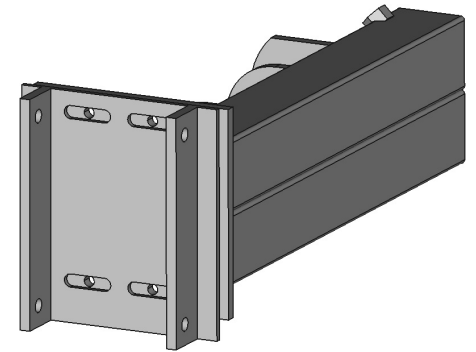
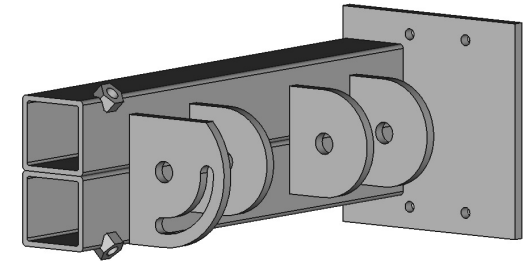
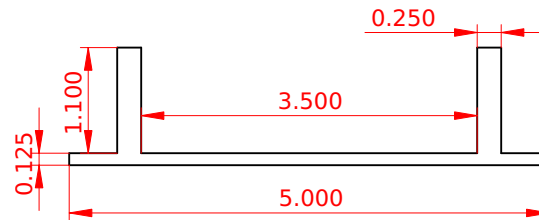
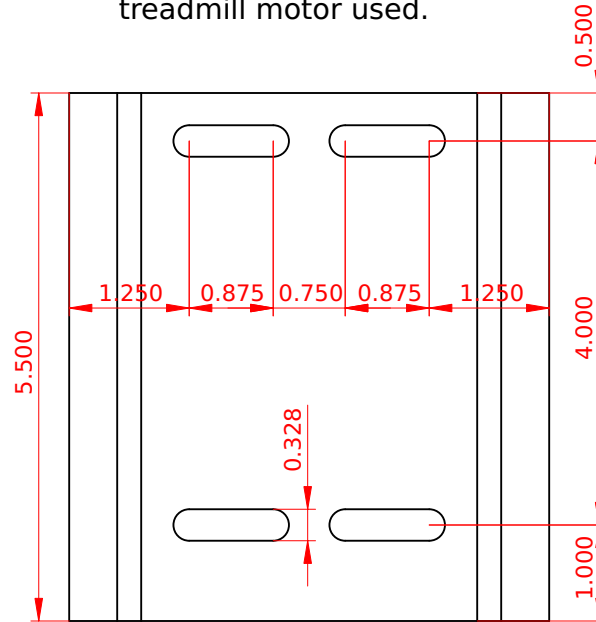

Copyright 2021 by Andrew H. Wakefield
Released under Creative Commons 4.0 BY-SA



Designed by
Andrew H. Wakefield

Scale
1:2

Default Dim.
+/- .005"

Title
Belt Grinder

Sheet
9

Revision
1

Date
9/25/2021

D

C

B

A

3

3

2

2

1

1