

| PARTS LIST | | | |
|------------|-----|------------------|---------------------|
| ITEM | QTY | PART NUMBER | DESCRIPTION |
| 1 | 1 | Valve | MATERIAL: 360 BRASS |
| 2 | 1 | Valve Cam Tappet | BRASS |

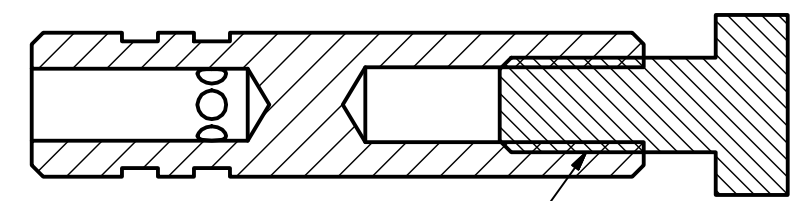

LOCTITE BLUE,
THREAD TAPE,
OR INTERFERENCE
FIT TO SECURE IN
PLACE

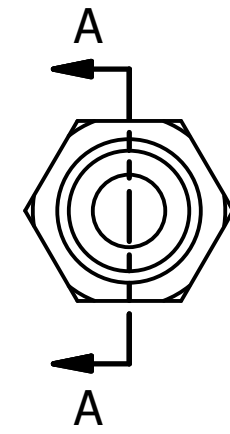
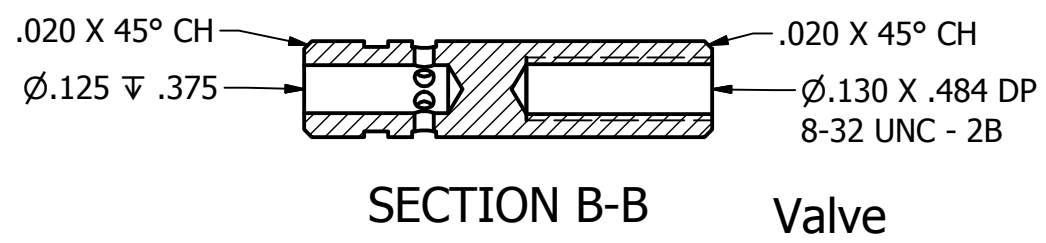
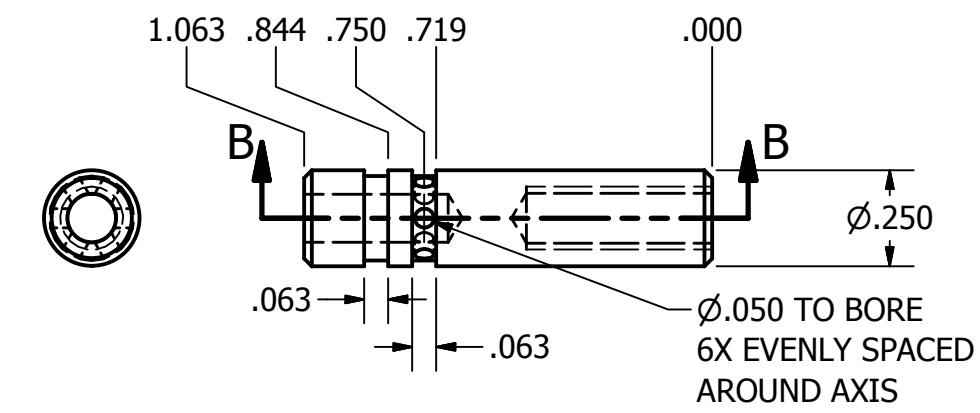
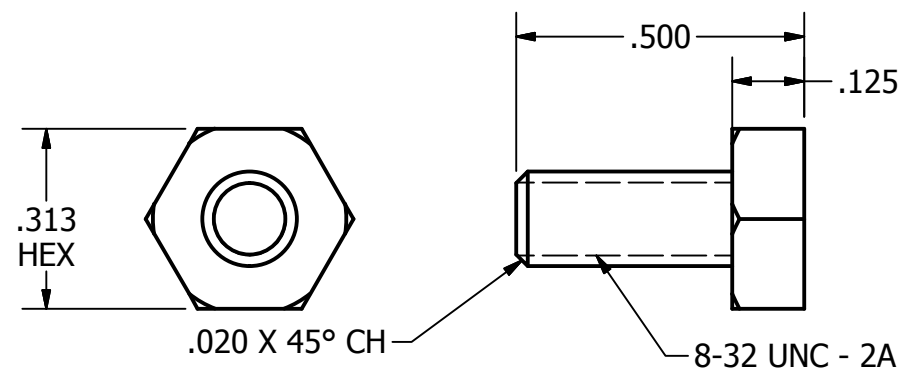
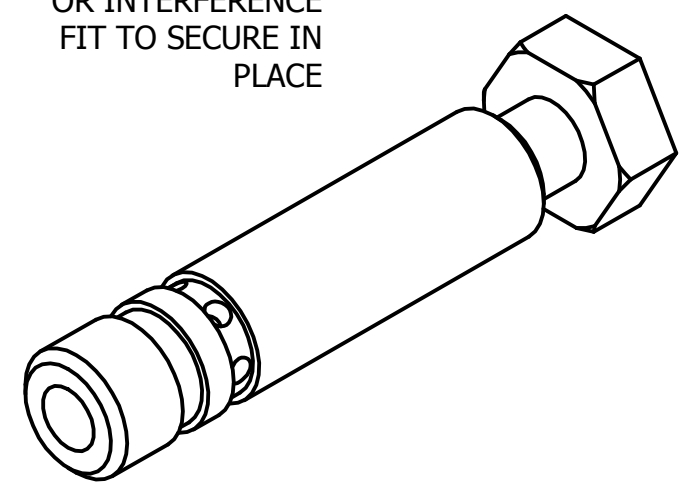

| | | | |
|--------------|-----------|----------------------|------------------------|
| DRAWN Rob | 11/7/2021 | Chirico Engine Works | |
| CHECKED | | TITLE | |
| QA | | VALVE ASSEMBLY | |
| MFG | | SIZE B | DWG NO Assy - Valve |
| APPROVED | | SCALE | REV |
| | | SHEET 1 OF 1 | |