

2

1

PARTS LIST			
ITEM	QTY	PART NUMBER	DESCRIPTION
1	1	Piston	MATERIAL: AL OR BRASS

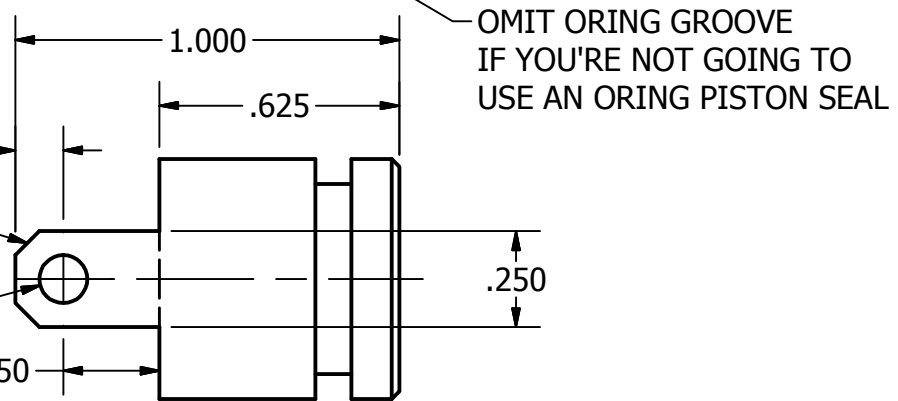
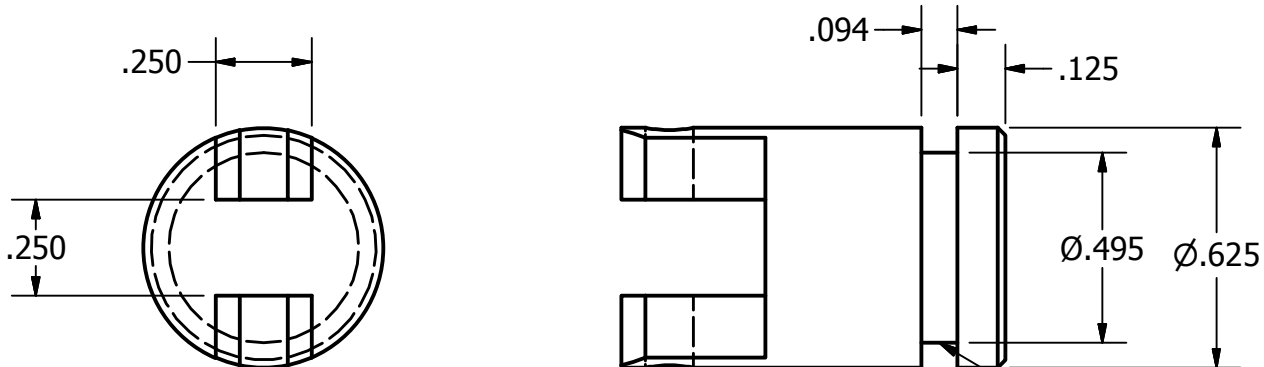

2X.063 X 45° CH

R.063 REAM

OMIT ORING GROOVE
IF YOU'RE NOT GOING TO
USE AN ORING PISTON SEAL

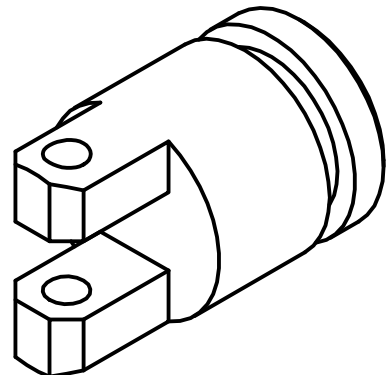

DRAWN	Rob	11/7/2021
CHECKED		
QA		
MFG		
APPROVED		

Chirico Engine Works		
TITLE		
PISTON		
SIZE	DWG NO	REV
A	Piston	
SCALE	SHEET 1 OF 1	

2

1