

Part: Assembly Isometric View

Material

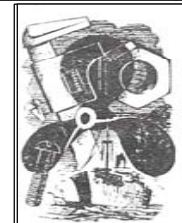

© **BOB HOLME**
 Engineering Service and Repair
 Mobile: AU 0466 979 291
 Int 61+466 979 291
 Email: Maryak@homemodelenginemachinist.com

			Title	William Fairbairn 10 hp Steam Engine	
			Scale		Date:
REV	DATE		DESCRIPTION		

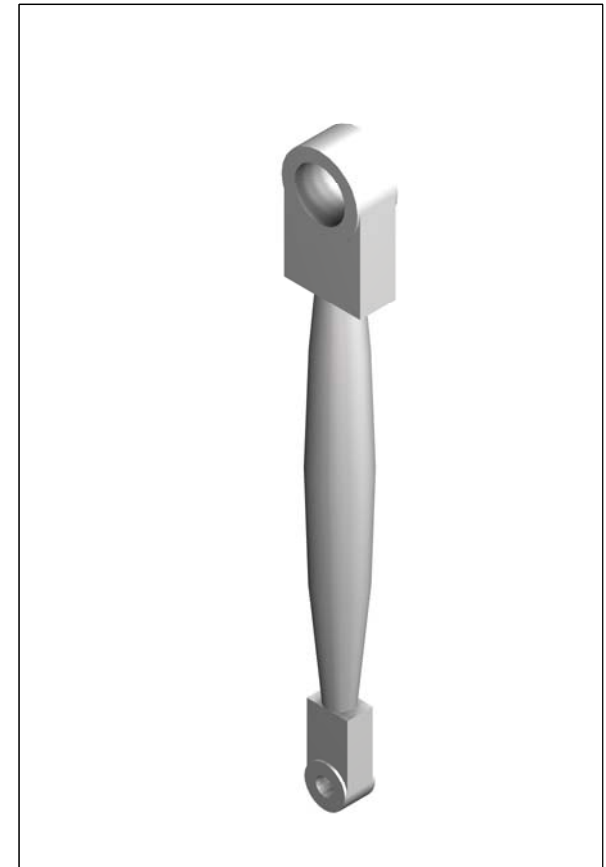
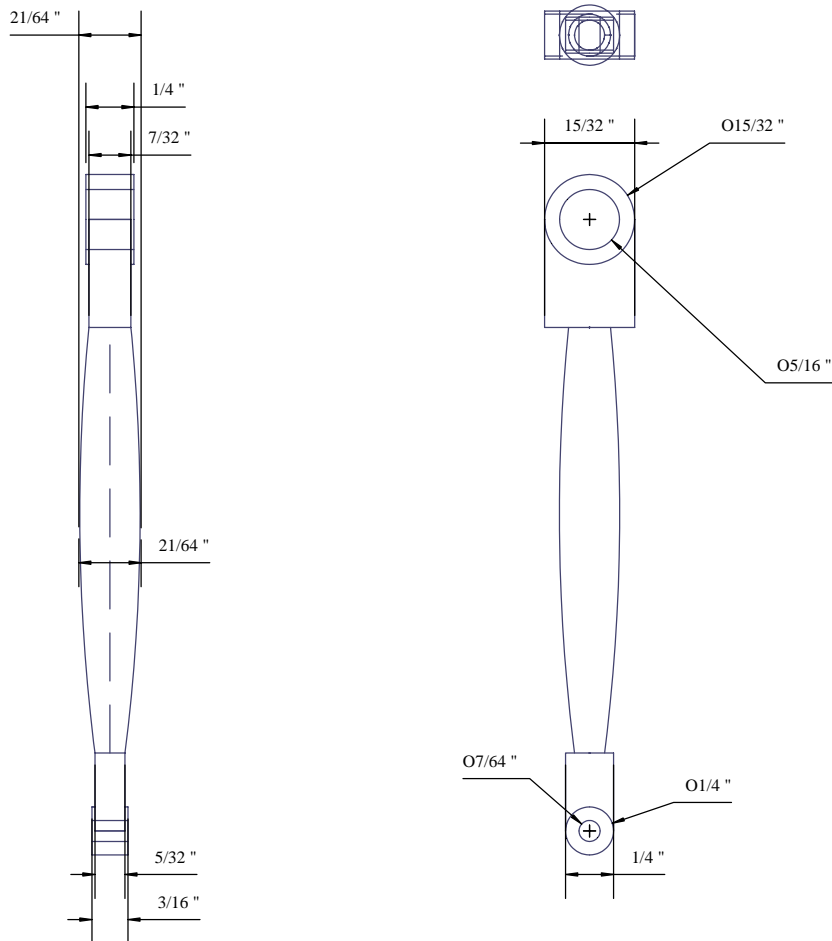

Part: **Connecting Rod**

Material: **Mild Steel**

REV	DATE	DESCRIPTION

Title: **William Fairbairn 10 hp Steam Engine**

Scale: **1 : 1** Date: **06 Jun 2011**

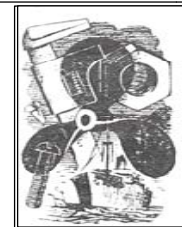

© **BOB HOLME**
 Engineering Service and Repair
 Mobile: AU 0466 979 291
 Int 61+466 979 291
 Email: Maryak@homemodelenginemachinist.com

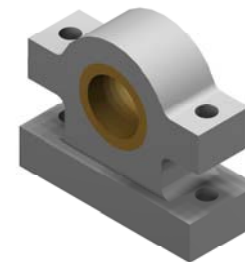
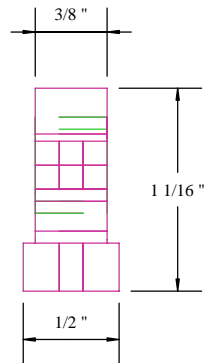
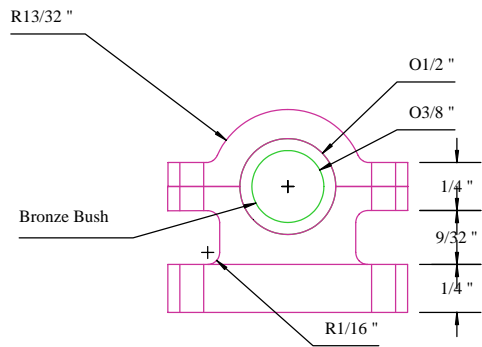
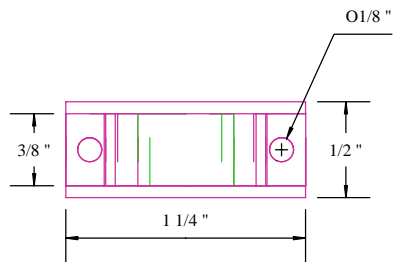

Part: Main Bearing 2 off

Material: Steel with Bronze Bush

REV	DATE	DESCRIPTION

Title	William Fairbairn 10 hp Steam Engine	
Scale	1 : 1	Date: 15 June 2011

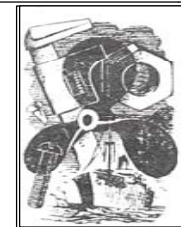

© **BOB HOLME**
 Engineering Service and Repair
 Mobile: AU 0466 979 291
 Int 61+466 979 291
 Email: Maryak@homemodelenginemachinist.com

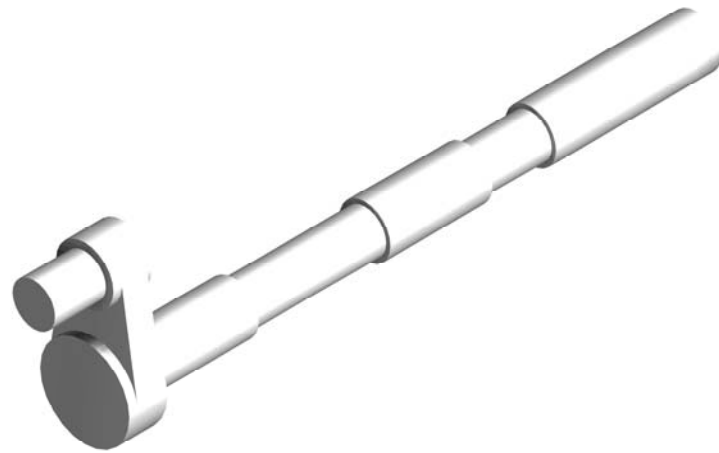
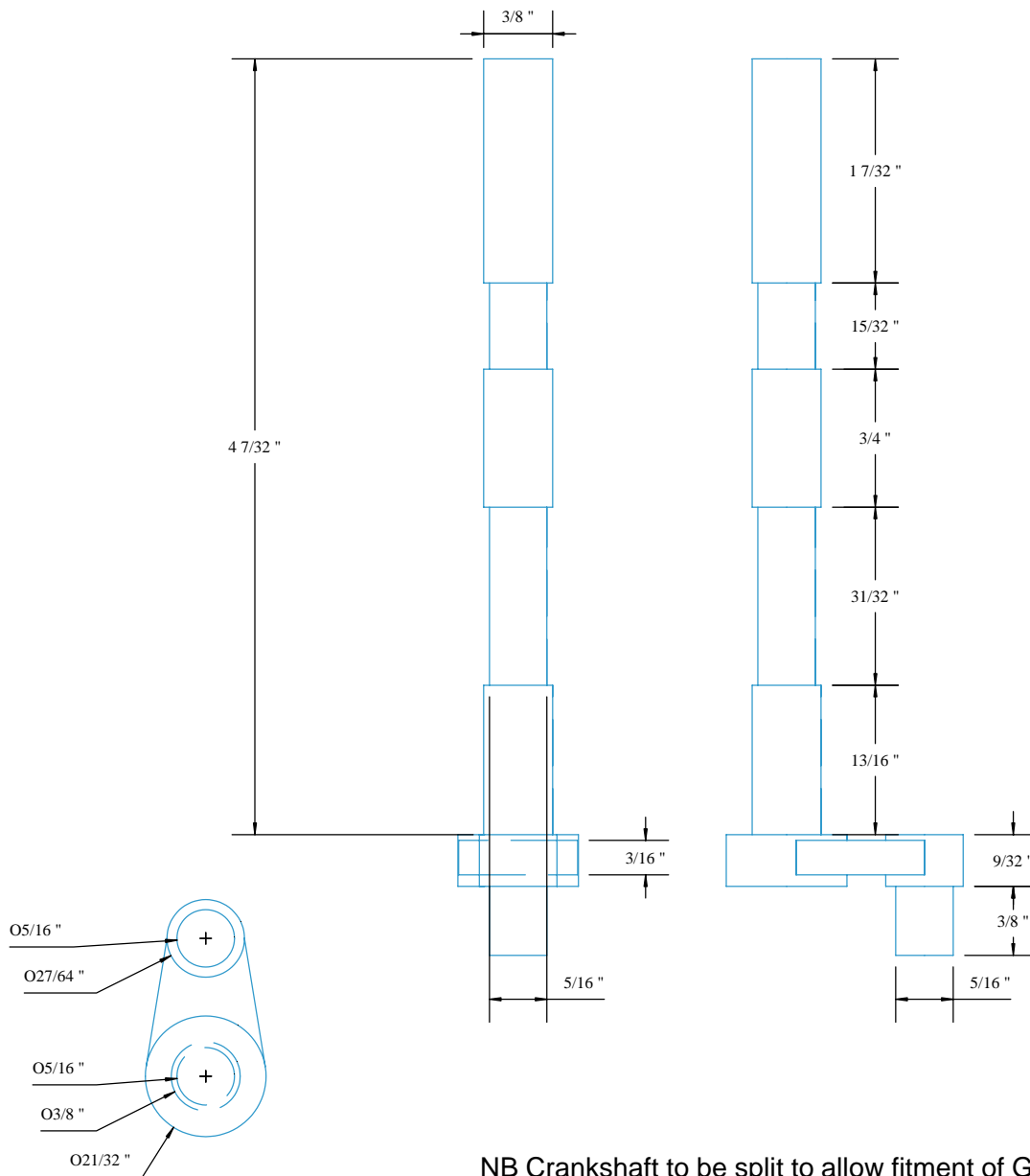

NB Crankshaft to be split to allow fitment of Governor drive gear.

Part: **Crankshaft**

Material: **Mild steel**

REV	DATE	DESCRIPTION

Title	William Fairbairn 10 hp Steam Engine	
Scale	1 : 1	Date: 01 Jun 2011

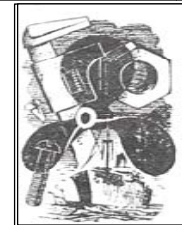

© **BOB HOLME**
 Engineering Service and Repair
 Mobile: AU 0466 979 291
 Int 61+466 979 291
 Email: Maryak@homemodelenginemachinist.com

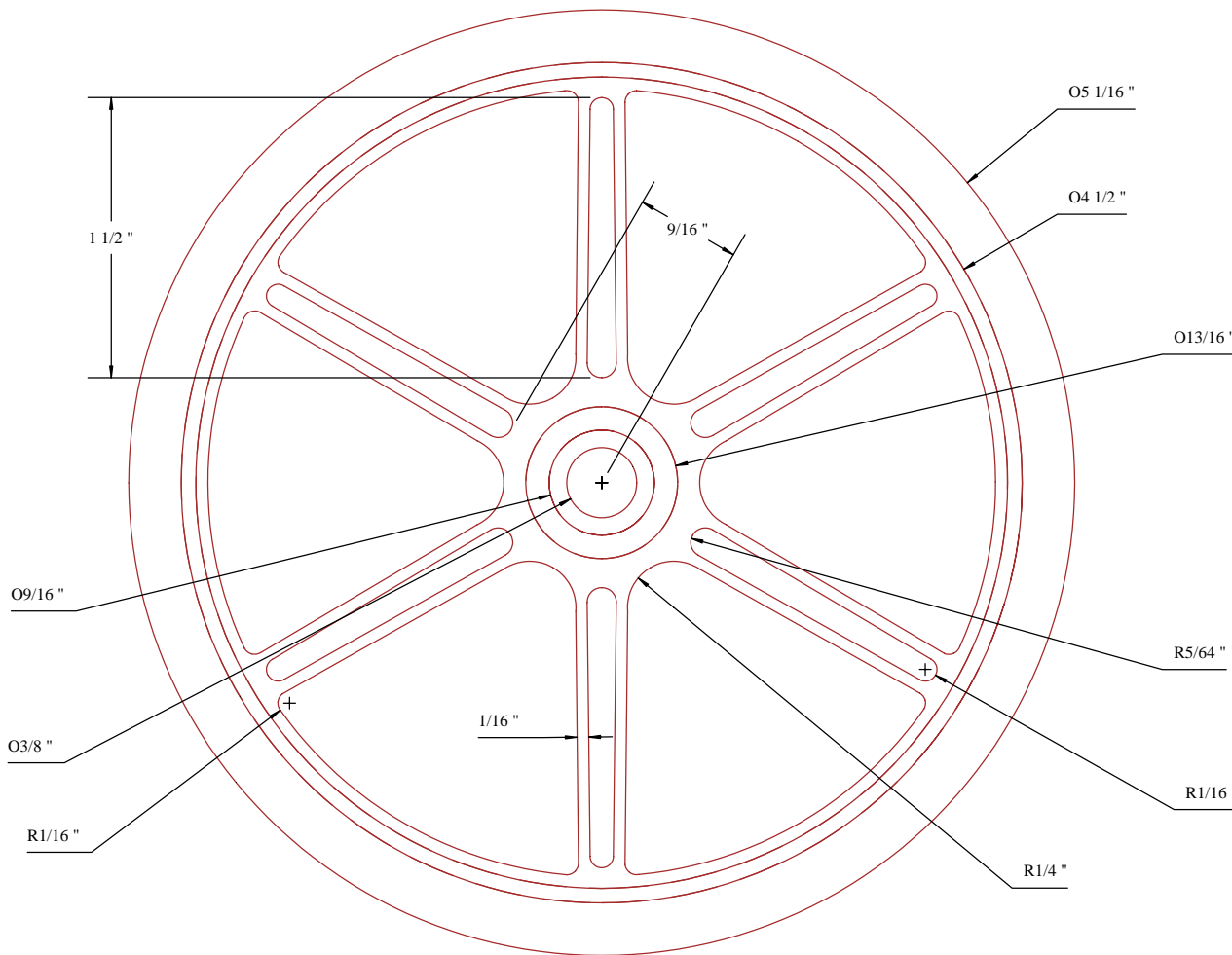
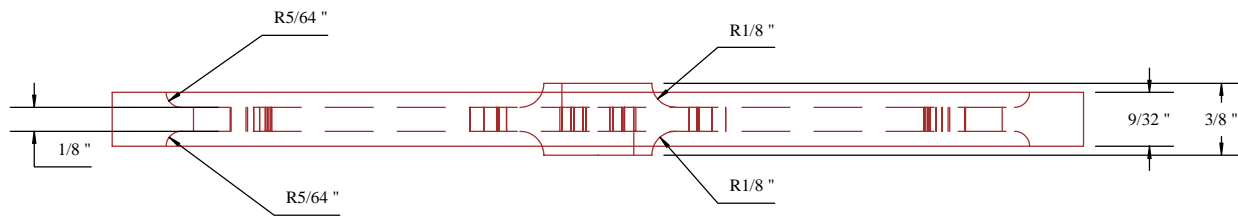

Part: Flywheel

Material: Mild steel

REV	DATE	DESCRIPTION

Title	William Fairbairn 10 hp Steam Engine	
Scale	1 : 1	Date: 30 June 2011

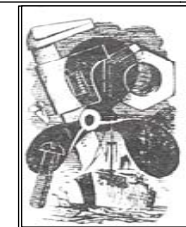

© **BOB HOLME**
 Engineering Service and Repair
 Mobile: AU 0466 979 291
 Int 61+466 979 291
 Email: Maryak@homemodelenginemachinist.com

20 degree Involute fine pitch bevel gear

Teeth 20
 DP 30
 Addendum 0.033
 Dedendum 0.042
 Work depth 0.067
 Whole depth 0.075
 PCD 0.667
 OD 0.733
 Large end Dimensions

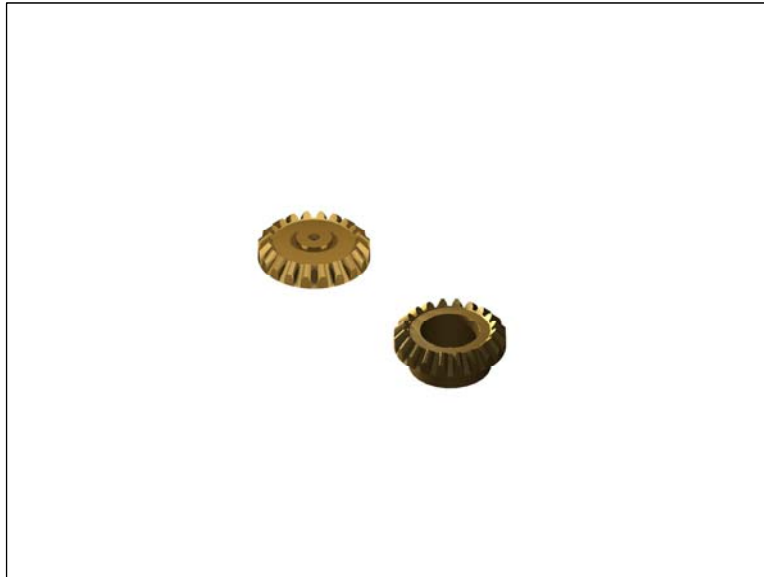
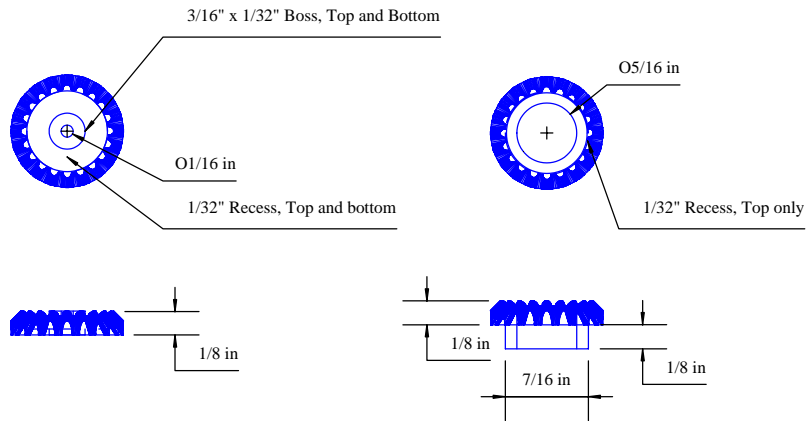

Part: Governor Bevel Gears

Material: Bronze

			Title	William Fairbairn 10 hp Steam Engine	
			Scale	1 : 1	Date: 03 July 2011
REV	DATE	DESCRIPTION			

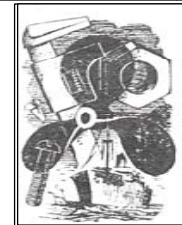

© **BOB HOLME**
 Engineering Service and Repair
 Mobile: AU 0466 979 291
 Int 61+466 979 291
 Email: Maryak@homemodelenginemachinist.com