

PINION GEAR AND BUSHING
2X SIZE

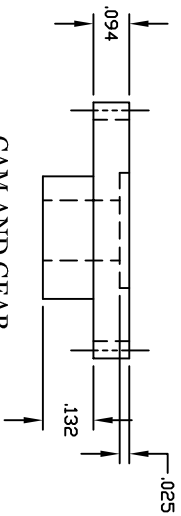

CAM AND GEAR
2X SIZE

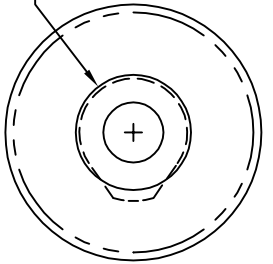
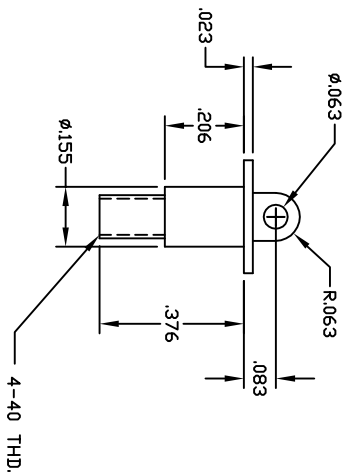
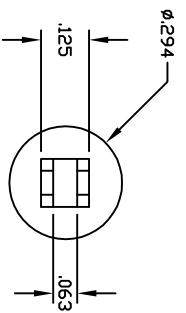

CAM GEAR BOLT
2X SIZE
TIGHTEN IN PLACE
BEFORE MACHINING SQUARE

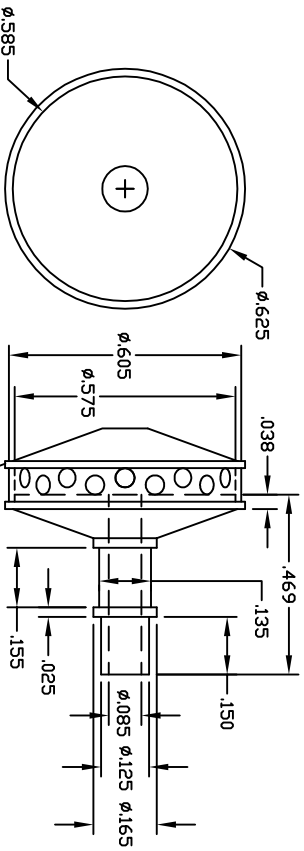

DRILL .05 DIA. HOLES
2 ROWS DN 30 DEGREE
CENTERS

PRESS OR SOLDER PIECES TOGETHER

MUFFLER
2X SIZE

AIR COOLED VERSION

REVISIONS BY GEORGE D. BRITNELL

TINY HIT AND MISS