

PARTS LIST			
ITEM	QTY	PART NUMBER	DESCRIPTION
1	1	Crankshaft - 02	MATERIAL: CRS
2	2	Crankshaft - 01	MATERIAL: CRS
3	1	Gear, Bevel, Crankshaft	MATERIAL: 360 BRASS
4	2	.250 dia x 0.500 lg x 10-32 thread Shoulder Screw	.125 dia x .406 lg x 4-40 thread Shoulder Screw
5	2	0803COPS	10-32 X 1/4 CUP POINT SETSCREW
6	4	0806COPS	10-32 X 1/4 CUP POINT SETSCREW

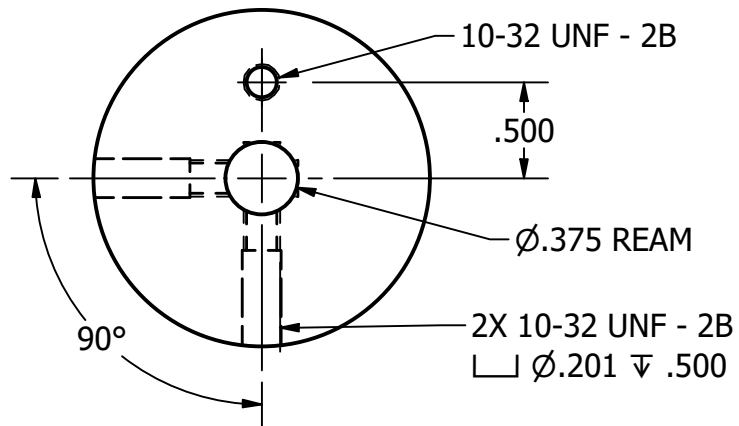

Crankshaft - 01

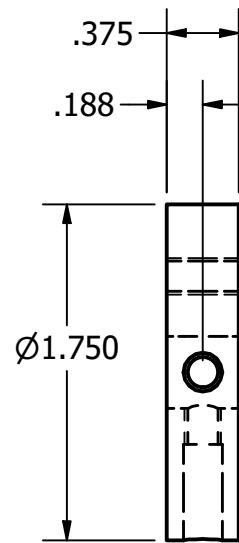
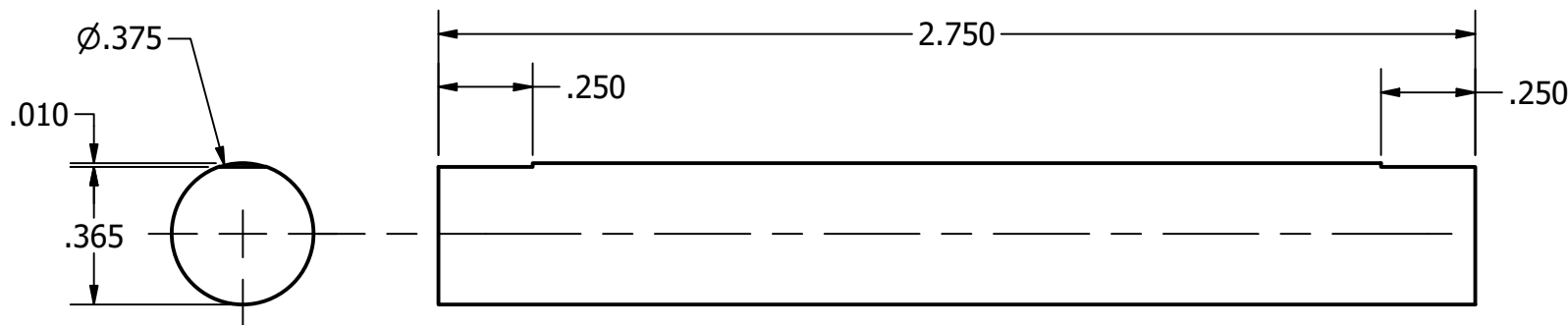
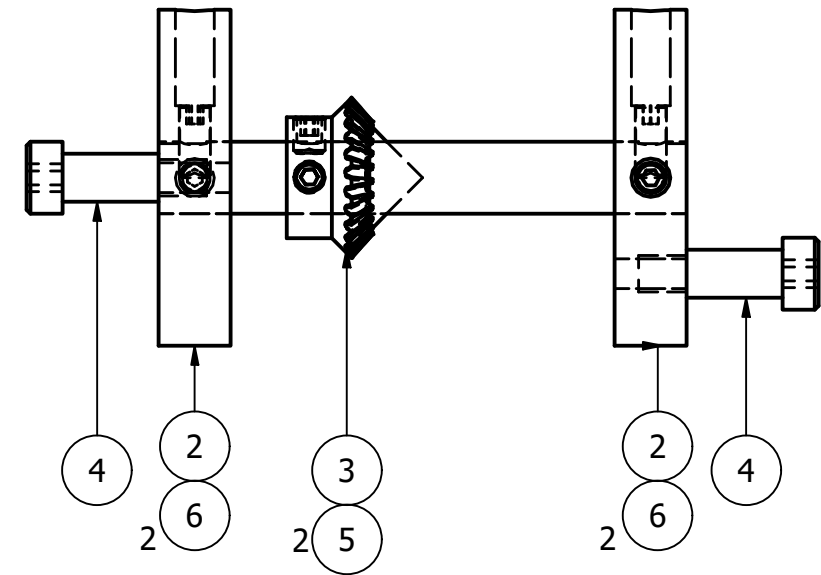
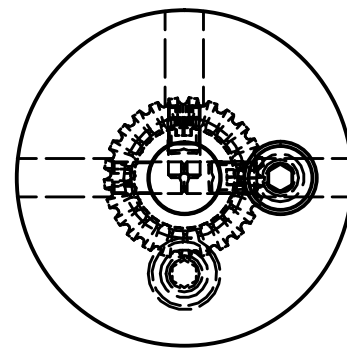

Crankshaft - 02

DRAWN Rob	4/9/2022	Chirico Engine Works		
CHECKED		TITLE		
QA		CRANKSHAFT ASSMBLY		
MFG		SIZE B	DWG NO Assy - Crankshaft	REV
APPROVED		SCALE	SHEET 1 OF 1	