

ITEM NO.	DWG NO.	DESCRIPTION	MATERIAL	SIZE	NOTES	QN'TY
1		BUNKER ASSEMBLY				1
2	9	FIREBOX WRAPPER	21 GA. MILD STEEL			1
3	11	FIREBOX THROAT SHEET	21 GA. MILD STEEL			1
4	10	HORN PLATE (LT)	21 GA. MILD STEEL			1
5	10	HORN PLATE (RT)	21 GA. MILD STEEL			1
6	17	PLATFORM UNDERFRAME-LT	21 GA. MILD STEEL			1
7	17	PLATFORM UNDERFRAME-RT	21 GA. MILD STEEL			1
8	15	PLATFORM SIDE (LT)	21 GA. MILD STEEL			1
9	15	PLATFORM SIDE (RT)	21 GA. MILD STEEL			1
10	12	FIREBOX BACK SHEET	21 GA. MILD STEEL			1
11	18	PLATFORM	21 GA. MILD STEEL			1
12	24	FUEL BUNKER REAR	21 GA. MILD STEEL			1
13	19	FUEL BUNKER INSIDE-LT	21 GA. MILD STEEL			1
14	19	FUEL BUNKER INSIDE-RT	21 GA. MILD STEEL			1
15	22	FUELBUNKER SIDE-LT	21 GA. MILD STEEL			1
16	22	FUELBUNKER SIDE-RT	21 GA. MILD STEEL			1
17	23	MOTION SUPPORT PLATE	21 GA. MILD STEEL			1
18	16	REAR STEP	21 GA. MILD STEEL			1
19	21	DRAWBAR	21 GA. MILD STEEL			1
20	80	STEERING BRKT. MT. -LT	21 GA. MILD STEEL			1
21	80	STEERING BRKT. MT. -RT	21 GA. MILD STEEL			1
22	25	VALVE ROCKER MT.	21 GA. MILD STEEL			1
23		RIVET		18 GA.		156

REV.	DATE	DESCRIPTION
0		

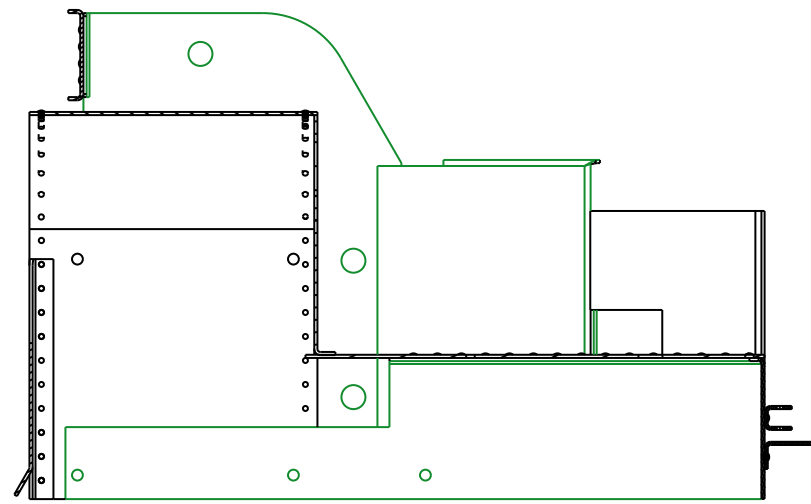

GENERAL TOLERANCES UNLESS NOTED							
.XXX .XX ANGLES							
DRAWN:		JCM	DATE	SIZE	DRAWING NAME		
CHECKED:			DATE	B	BUNKER ASSEMBLY		
				SCALE: AS SHOWN	DWG. NO.:	SHEET	1 OF 2



SECTION A-A
SCALE 0.500

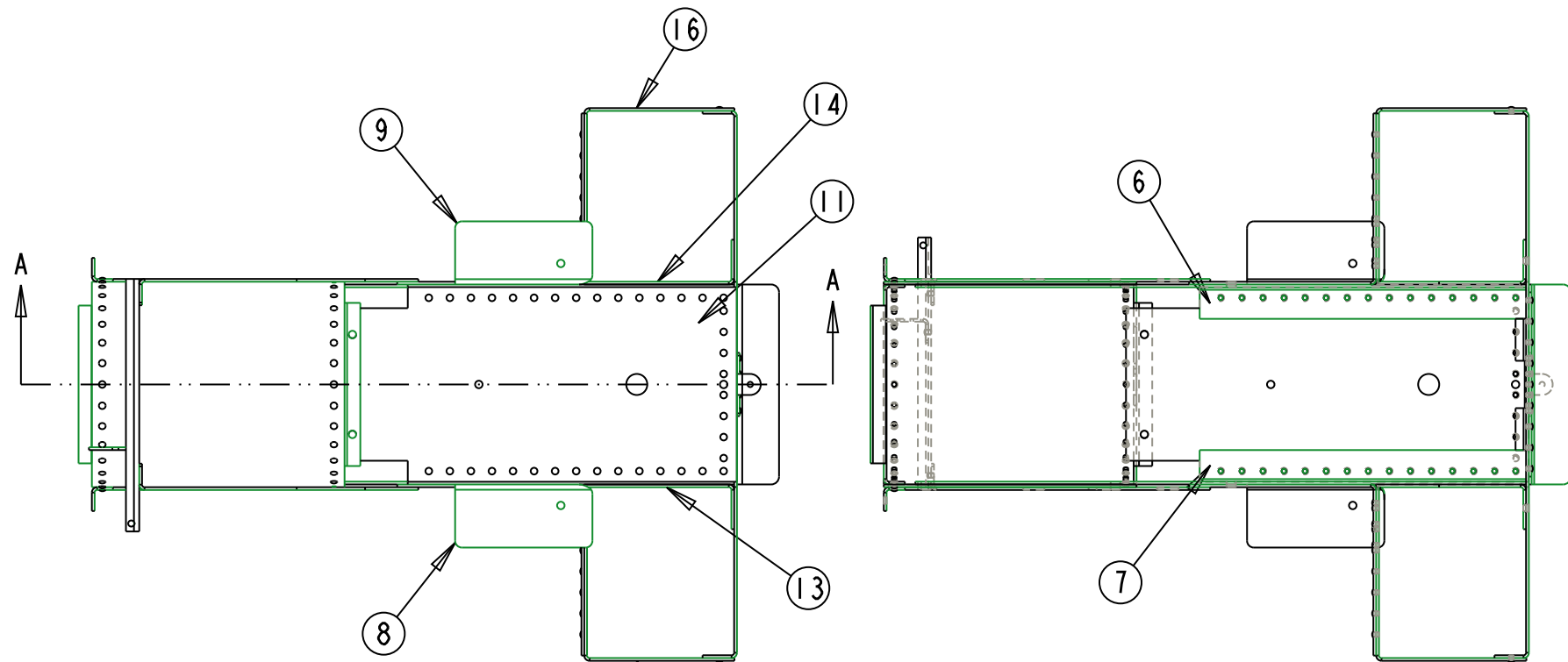

BOTTOM VIEW

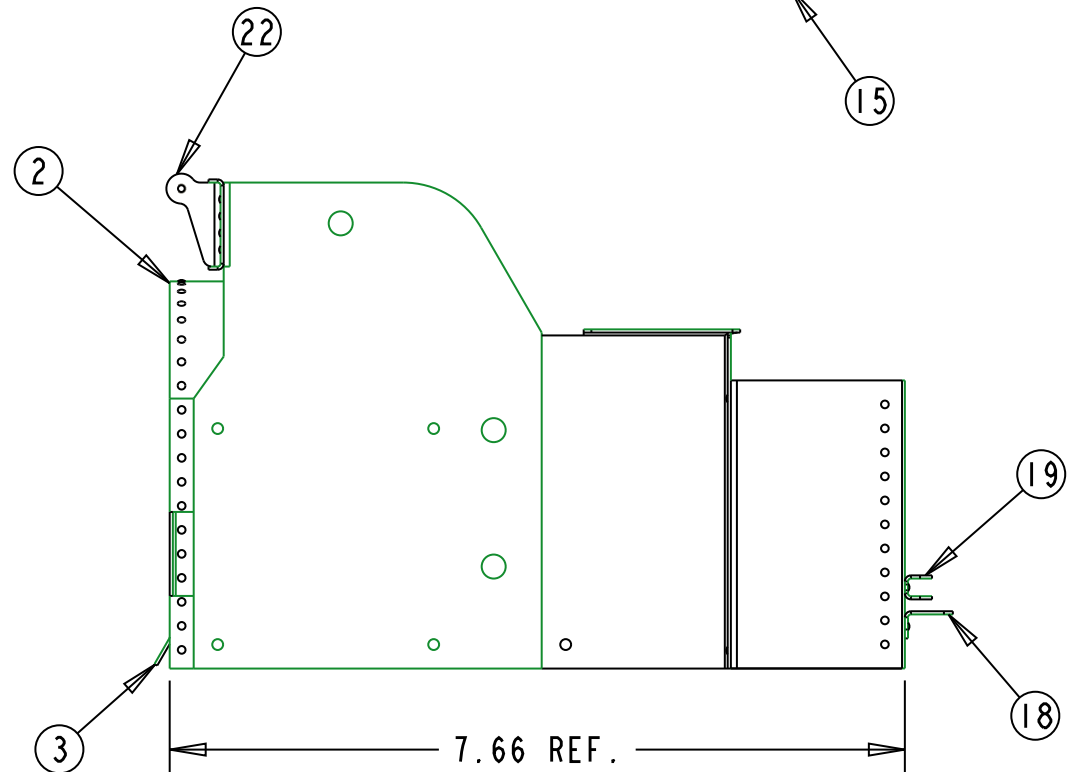
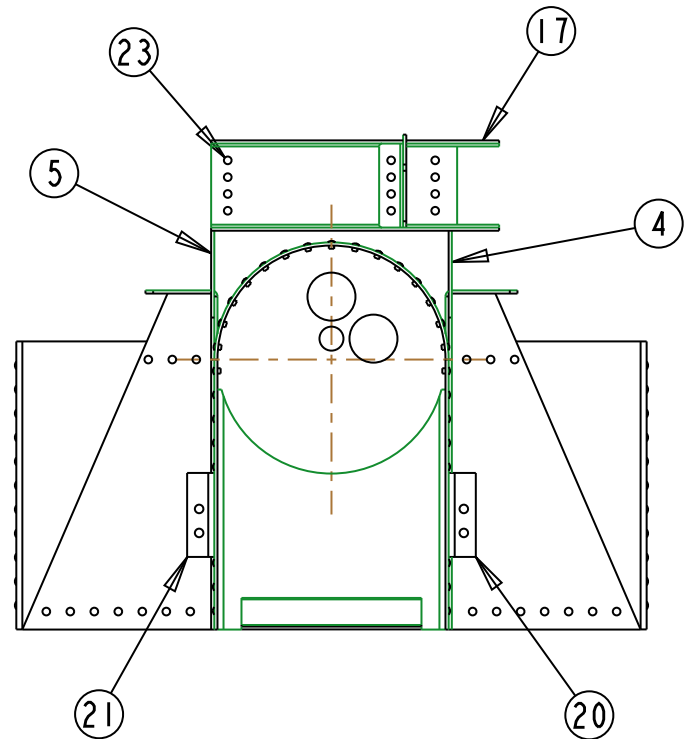
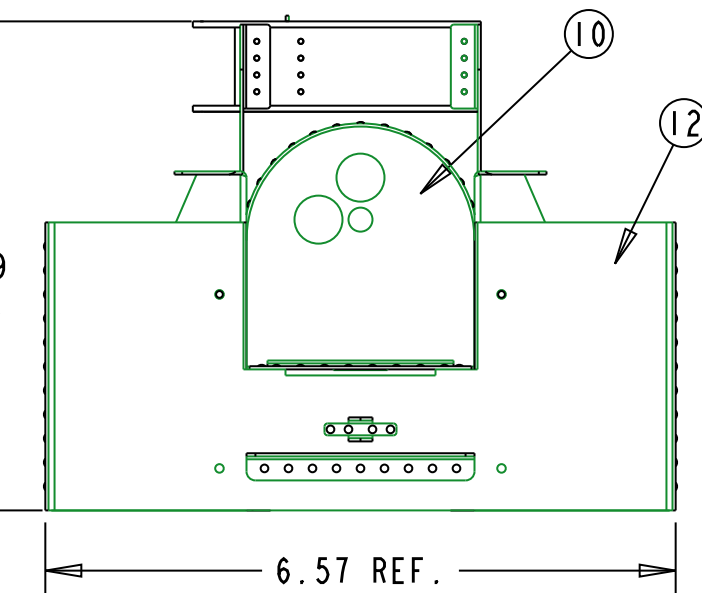

SCALE 0.500



REV.	DATE	DESCRIPTION
0		

GENERAL TOLERANCES UNLESS NOTED					
.XXX .XX ANGLES					
DRAWN: JCM		DATE		SIZE B	DRAWING NAME
CHECKED:		DATE		BUNKER ASSEMBLY	
SCALE: AS SHOWN			DWG. NO.:		SHEET 2 OF 2