

1

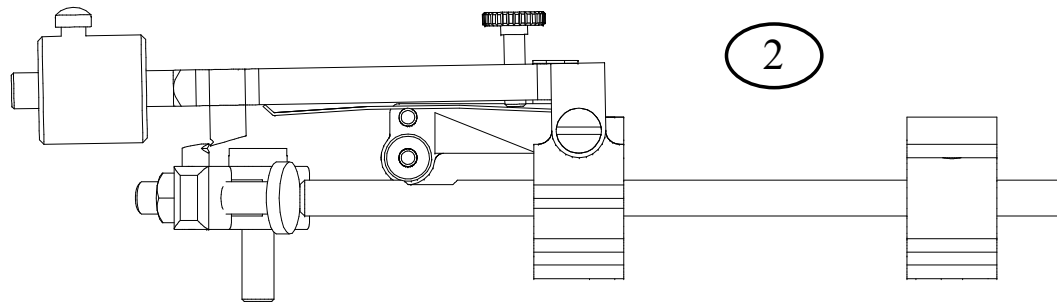

2

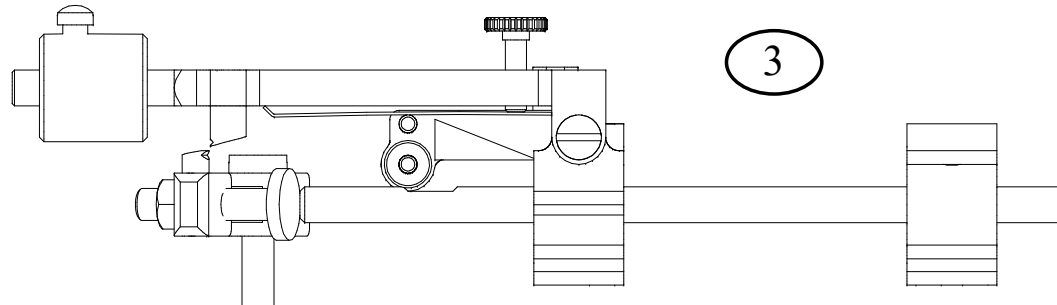

3

PW GOVERNOR
DIAGRAM

SCALE - 1.5:1

NOTES:

1. CONDITION #1 - Pushrod is fully extended allowing pawls to pass each other and allowing governor roller to drop into recess on top of pushrod. Governor rocker, attached weight, and governor arm also drop. Exhaust valve is depressed fully. This condition is repeated at all speeds.
2. CONDITION #2 - Engine running at or above governed speed. While pushrod retracts, the roller exits the pushrod depression. Governor arm, weight, etc. remains stationary due to inertia, compressing governor spring and allowing pawls on governor arm and exhaust valve to catch. Condition is repeated as engine continues to run at governed speed.
3. CONDITION #3 - Engine running below governed speed. While pushrod retracts, the roller exits the pushrod depression. Governor arm, weight, etc. rise due to stiffness of governor spring being sufficient to overcome inertia of the governor weight, etc. and allowing pawls on governor arm and exhaust valve to pass each other, drawing in a fresh charge and allowing engine to fire.

TITLE: PARSELL & WEED 1/2 Hp ENGINE	
PART: GOVERNOR	NMBR: E00
DESIGN BY: Woody Sims	DATE: 1/4/1994
REVISED & REDRAWN BY: Todd W. Snouffer	DATE: 4/20/16