



## **Vehicle Standard (Australian Design Rule 51/00 – Filament Lamps) 2006**

I, JAMES ERIC LLOYD, Minister for Local Government, Territories and Roads,  
determine this vehicle standard under subsection 7 (1) of the *Motor Vehicle Standards  
Act 1989*.

Dated            23 September 2006

[SIGNED]

James Eric Lloyd

Minister for Local Government, Territories and Roads

**CONTENTS**

0.	LEGISLATIVE PROVISIONS.....	3
1.	SCOPE.....	3
2.	APPLICABILITY AND IMPLEMENTATION.....	3
3.	DEFINITIONS .....	3
4.	REQUIREMENTS .....	3
5.	EXEMPTIONS AND ALTERNATIVE PROCEDURES .....	4
6.	SUPPLEMENTARY GENERAL REQUIREMENTS .....	4
7.	ALTERNATIVE STANDARDS .....	4
8.	NOTES .....	5

**0. LEGISLATIVE PROVISIONS****0.1. NAME OF STANDARD**

0.1.1. This Standard is the Vehicle Standard (Australian Design Rule 51/00 – Filament Lamps) 2006.

0.1.2. This Standard may also be cited as Australian Design Rule 51/00 — Filament Lamps.

**0.2. COMMENCEMENT**

0.2.1. This Standard commences on the day after it is registered.

**0.3. REPEAL**

0.3.1. This Standard repeals each vehicle standard with the name Australian Design Rule 51/00 — Filament Lamps that is:

(a) made under section 7 of the Motor Vehicle Standards Act 1989; and

(b) in force at the commencement of this Standard.

0.3.2. This Standard also repeals each instrument made under section 7 of the Motor Vehicle Standards Act 1989 that creates a vehicle standard with the name Australian Design Rule 51/00 — Filament Lamps, if there are no other vehicle standards created by that instrument, or amendments to vehicle standards made by that instrument, that are still in force at the commencement of this Standard.

**1. SCOPE**

This Australian Design Rule (ADR) prescribes the dimensional and photometric requirements for filament lamps which ensure interchangeability and correct functioning when installed in a lamp unit.

**2. APPLICABILITY AND IMPLEMENTATION**

2.1. The circumstances under which lamps are mandatory, optional, or prohibited are set out in either ADRs 13/.., 19/... or 67/....

**3. DEFINITIONS**

3.1. Refer to paragraph 2.1 of Appendix A.

**4. REQUIREMENTS**

4.1. Devices complying with the technical requirements of Appendix A, part 5 Exemptions and Alternative Procedures and part 6 Supplementary General Requirements shall be accepted as complying with this vehicle standard.

## **5. EXEMPTIONS AND ALTERNATIVE PROCEDURES**

5.1. The following provisions of Appendix A do not apply.

5.1.1. Administrative provisions

Section 2.2 Application for approval

Section 2.4 Approval

Section 3.8 Observation concerning selective yellow colour.

Section 5 Penalties for non conformity of production

Section 6 Production definitely discontinued

Section 7 Names and addresses of technical services responsible for conducting approval tests, and of administrative departments

Section 8 Transitional provisions

Annexes

Annex 2 Communication concerning the approval (or refusal or withdrawal of approval or production definitely discontinued) of a type of filament lamp pursuant to Regulation No. 37

Annex 3 Example of the arrangement of the approval mark

## **6. SUPPLEMENTARY GENERAL REQUIREMENTS**

The following general requirements are supplementary to the requirements of Appendix A:

6.1. The requirements and procedures set out in Annexes 6 and 7 of Appendix A are acceptable for the purposes of demonstrating compliance with the technical requirements of this rule.

6.2. In paragraph 3.10 of Appendix A, it is permissible to use filament lamps other than standard filament lamps listed in Annex 1 for photometric tests specified in lighting component ADRs which refer to ADR 51/... provided those filament lamps comply with paragraph 7.2 and other requirements of this Rule except for Annex 1.

6.3. In cases where it is not possible to meet the requirements of paragraph 2.3, Inscriptions, information necessary to ensure traceability of replaceable components affecting the photometric performance must be provided. This information shall be marked on the bulb, or the cap, or permanently marked on the lamp body.

## **7. ALTERNATIVE STANDARDS**

7.1. The technical requirements of any of the editions of United Nations – Economic Commission (UN ECE) for Europe Regulation No. 37 - UNIFORM PROVISIONS CONCERNING THE APPROVAL OF FILAMENT LAMPS FOR USE IN APPROVED LAMP UNITS OF POWER DRIVEN VEHICLES AND OF THEIR TRAILERS, up to and including the edition incorporating the 03 series of amendments are deemed to be equivalent to the technical requirements of this rule.

7.2. Filament lamps conforming to FMVSS 108 Lamps Reflective Devices and Associated Equipment, SAE J573 Dec89 Miniature Lamp Bulbs and

JIS C 7506 – 1994 Lamp Bulbs for Motor Vehicles, may be used in lighting and light signalling devices in which case the photometric test must be conducted as referenced in paragraphs 6.2 and 6.3 using either

- 7.2.1. a standard filament lamp which has been selected as specified in the relevant standard referenced in clause 7.2 above; or
- 7.2.2. where selection of standard filament lamp is not addressed in the standard chosen from those required in clause 7.2 above, then the light and light signalling device must be capable of meeting those photometric requirements using any of the filament lamps of the selected type that conform to the specifications in that standard.

## **8. NOTES**

- 8.1. In place of Regulation No 48 where referenced in Appendix A, read ADR 13/00.

**APPENDIX A**  
**UN-ECE REGULATION NO. 37/03**  
**UNIFORM PROVISIONS CONCERNING THE APPROVAL OF FILAMENT**  
**LAMPS FOR USE IN APPROVED LAMP UNITS OF POWER DRIVEN**  
**VEHICLES AND THEIR TRAILERS**

NOTE:

In view of recent changes to the Regulation, text containing Supplements 8 and 9 have not been incorporated in the main Regulation document. Supplements 8 and 9 have been attached at the end of R37/03. Changes in the texts of Supplements 8 and 9 will be incorporated into the Regulation when the consolidated document is available from the UN-ECE.

## **Regulation No. 37**

# **UNIFORM PROVISIONS CONCERNING THE APPROVAL OF FILAMENT LAMPS FOR USE IN APPROVED LAMP UNITS OF POWER DRIVEN VEHICLES AND OF THEIR TRAILERS**

## **CONTENTS**

### **REGULATION**

1. Scope
2. Administrative provisions
  - 2.1. Definitions
  - 2.2. Application for approval
  - 2.3. Inscriptions
  - 2.4. Approval
3. Technical requirements
  - 3.1. Definitions
  - 3.2. General specifications
  - 3.3. Manufacture
  - 3.4. Tests
  - 3.5. Filament position and dimensions
  - 3.6. Colour
  - 3.7. The UV radiation of a halogen filament
  - 3.8. lampObservation concerning selective-yellow colour
  - 3.9. Check on optical quality
  - 3.10. Standard filament lamps
4. Conformity of production
5. Penalties for non-conformity of production
6. Production definitely discontinued
7. Names and addresses of technical services responsible for conducting approval tests, and of administrative departments
8. Transitional provisions

### **ANNEXES**

- Annex 1 Sheets
- Sheets H1
  - Sheets H2
  - Sheets H3
  - Sheets H4
  - Sheets P21W
  - Sheet P21/4W
  - Sheets P21/5W
  - Sheet R5W
  - Sheet R10W
  - Sheet C5W
  - Sheets C21W (filament lamp for reversing lamp)
  - Sheet T4W
  - Sheet W5W
  - Sheet W3W
  - Sheets S1 and S2 (filament lamps for motor cycles)
  - Sheet S3 (filament lamp for mopeds)

### CONTENTS (continued)

	Sheets S4 (filament lamp for mopeds)
	Sheets HS1
	Sheets HS2 (halogen filament lamp for mopeds)
	Sheets PY21W (amber coloured filament lamp)
	Sheet H6W
	Sheets HB3
	Sheets HB4
	Sheet T1.4W
	Sheet H7
	Sheets H27W
	Sheets P27W
	Sheets P27W/7W
	Sheet WY5W
	Sheets H21W
	Sheets W21W
	Sheets W21/5W
	Sheets W2.3W
	Sheets H8
	Sheets W16W
	Sheets HIR1
	Sheets PY27/7W
	Sheets HIR2
	Sheets H9
	Sheets H10
Annex 2	Communication concerning the approval (or extension or refusal or withdrawal of approval or production definitely discontinued) of a type of filament lamp pursuant to Regulation No. 37
Annex 3	Example of the arrangement of the approval mark <sup>*/</sup>
Annex 4	Luminous centre and shapes of lamp filaments
Annex 5	Checking the colour and transmission of selective-yellow bulbs and outer bulbs and amber bulbs
Annex 6	Minimum requirements for quality control procedures by the manufacturer
Annex 7	Sampling and compliance levels for manufacturer tests records
Annex 8	Minimum requirements for spot checks by the administrative authority
Annex 9	Compliance approved by spot check

---

<sup>\*/</sup> The first five filament lamp categories were added by Supplement 10 to the 03 series of amendments to Regulation No.37 (TRANS/SC.1/WP.29/ R.652).

---



## Regulation No. 37

### UNIFORM PROVISIONS CONCERNING THE APPROVAL OF FILAMENT LAMPS FOR USE IN APPROVED LAMP UNITS OF POWER DRIVEN VEHICLES AND OF THEIR TRAILERS

#### 1. SCOPE

This Regulation applies to filament lamps shown in annex 1 and intended for use in approved lamp units of power driven vehicles and of their trailers.

#### 2. ADMINISTRATIVE PROVISIONS

##### 2.1. Definitions

##### 2.1.1. Definition of "category"

The term "category" is used in this Regulation to describe different basic design of standardized filament lamps. Each category has a specific designation, as for example: "F1", "P21W", "T4W".

##### 2.1.2. Definition of "type"

Filament lamps of different "types" are lamps within the same category which differ in such essential respects as:

##### 2.1.2.1. trade name or mark;<sup>1/</sup>

##### 2.1.2.2. bulb design, in so far as these differences affect the optical results;

##### 2.1.2.3. bulb colour

A selective-yellow bulb or an additional selective-yellow outer bulb, solely intended to change the colour but not the other characteristics of a colourless filament lamp, does not constitute a change of type of the filament lamp;

##### 2.1.2.4. rated voltage.

##### 2.2. Application for approval

##### 2.2.1. The application for approval shall be submitted by the owner of the trade name or mark, or by his duly accredited representative.

##### 2.2.2. Every application for approval shall be accompanied (see also para. 2.4.2.) by:

##### 2.2.2.1. drawings in triplicate, sufficiently detailed to permit identification of the type;

##### 2.2.2.2. a brief technical description;

##### 2.2.2.3. five samples of each colour which has been applied for.

##### 2.2.3. In the case of a type of filament lamp differing only by the trade name or mark from a type that has already been approved it shall be sufficient to submit:

---

<sup>1/</sup> Filament lamps bearing the same trade name or mark but produced by different manufacturers are considered as being of different types. Filament lamps produced by the same manufacturer differing only by the trade name or mark may be considered to be of the same type.

- 2.2.3.1. a declaration by the lamp manufacturer that the type submitted is identical (except in the trade name or mark) with and has been produced by the same manufacturer as, the type already approved, the latter being identified by its approval code;
- 2.2.3.2. two samples bearing the new trade name or mark.
- 2.2.4. The competent authority shall verify the existence of satisfactory arrangements for ensuring effective control of the conformity of production before type approval is granted.
- 2.3. Inscriptions
- 2.3.1. Filament lamps submitted for approval shall bear on the cap or bulb:<sup>2/</sup>
- 2.3.1.1. the trade name or mark of the applicant;
- 2.3.1.2. the rated voltage;
- 2.3.1.3. the international designation of the relevant category;
- 2.3.1.4. the rated wattage (in the sequence, principal filament/secondary filament for dual- filament lamps); this need not be indicated separately if it is part of the international designation of the relevant filament lamp category;
- 2.3.1.5. a space of sufficient size to accommodate the approval mark.
- 2.3.2. The space mentioned in paragraph 2.3.1.5. above shall be indicated in the drawings accompanying the application for approval.
- 2.3.3. Halogen filament lamps<sup>\*/</sup> meeting the requirements of paragraph 3.7. below shall be marked with a "U".
- 2.3.4. Other inscriptions than those covered by paragraphs 2.3.1. and 2.4.3. may be affixed, on the condition that they do not adversely affect the luminous characteristics.
- 2.4. Approval
- 2.4.1. If all the samples of a type of filament lamp which are submitted in pursuance of paragraphs 2.2.2.3. or 2.2.3.2. above meet the requirements of this Regulation, approval shall be granted.
- 2.4.2. An approval code shall be assigned to each type approved. Its first character (at present 2 corresponding to the 02 series of amendments which entered into force on 27 October 1983 and to the 03 series of amendments, not requiring changes in the approval number, which entered into force on 1 June 1984) shall indicate the series of amendments incorporating the most recent major technical amendments made to the Regulation at the time of issue of the approval. This will be followed by an identification code comprising not more than two characters. Only the arabic numerals and capital letters listed in footnote<sup>3/</sup> shall be used. The same Contracting Party may not assign the same code to another type of filament lamp. Notice of approval or of extension or refusal or withdrawal of approval or

---

<sup>2/</sup> In this latter case, the luminous characteristics shall not be adversely affected.

<sup>\*/</sup> Halogen filament lamps are filament lamps whose category designation starts with the letter "H".

<sup>3/</sup> 0 1 2 3 4 5 6 7 8 9  
A B C D E F G H J K L M N P R S T U V W X Y Z

production definitely discontinued of a type of filament lamp pursuant to this Regulation shall be communicated to the Parties to the 1958 Agreement which apply this Regulation by means of a form conforming to the model in annex 2 to this Regulation. If the applicant so desires the approval code may be assigned to the colourless and to the selective-yellow filament lamp (see para. 2.1.2.3.).

- 2.4.3. To every filament lamp conforming to a type approved under this Regulation there shall be affixed in the space referred to in paragraph 2.3.1.5., in addition to the inscriptions required under paragraph 2.3.1., an international approval mark consisting of:
  - 2.4.3.1. a truncated circle surrounding the letter "E" followed by the distinguishing number of the country which has granted approval;<sup>4/</sup>
  - 2.4.3.2. the approval code, placed close to the truncated circle.
- 2.4.4. If the applicant has obtained the same approval code for several trade names or marks, one or more of them will suffice to meet the requirements of paragraph 2.3.1.1.
- 2.4.5. The marks and inscriptions specified in paragraphs 2.3.1. and 2.4.3. shall be clearly legible and be indelible.
- 2.4.6. Annex 3 to this Regulation gives an example of arrangement of the approval mark.

### **3. TECHNICAL REQUIREMENTS**

#### **3.1. Definitions**

- 3.1.1. Rated voltage: voltage (in V) marked on the filament lamp;
- 3.1.2. Rated wattage: wattage (in W) marked on the filament lamp which may be incorporated into the international designation of the relevant category;
- 3.1.3. Test voltage: voltage, at the filament lamp terminals for which the electrical and photometric characteristics of the filament lamp are intended and are to be tested;
- 3.1.4. Objective values: values to be achieved, within the specified tolerances, when the filament lamp is supplied with current at its test voltage;
- 3.1.5. Standard filament lamp: a lamp with colourless bulb (except for amber filament lamps) and with reduced dimensional tolerances, used for the

---

<sup>4/</sup> 1 for Germany, 2 for France, 3 for Italy, 4 for the Netherlands, 5 for Sweden, 6 for Belgium, 7 for Hungary, 8 for the Czech Republic, 9 for Spain, 10 for Yugoslavia, 11 for the United Kingdom, 12 for Austria, 13 for Luxembourg, 14 for Switzerland, 15 (vacant), 16 for Norway, 17 for Finland, 18 for Denmark, 19 for Romania, 20 for Poland, 21 for Portugal, 22 for the Russian Federation, 23 for Greece, 24 (vacant), 25 for Croatia, 26 for Slovenia, 27 for Slovakia, 28 for Belarus, 29 for Estonia, 30 (vacant), 31 for Bosnia and Herzegovina, 32-36 (vacant), 37 for Turkey, 38-39 (vacant) and 40 for The former Yugoslav Republic of Macedonia. Subsequent numbers will be assigned to other countries in the chronological order in which they ratify or accede to the Agreement Concerning the Adoption of Uniform Technical Prescriptions for Wheeled Vehicles, Equipment and Parts which can be Fitted and/or be Used on Wheeled Vehicles and the Conditions for Reciprocal Recognition of Approvals Granted on the Basis of these Prescriptions, and the numbers thus assigned shall be communicated to the Contracting Parties to the Agreement by the Secretary-General of the United Nations.

testing of lighting devices. Standard filament lamps are specified in only one voltage rating for each category;

- 3.1.6. Reference luminous flux: specified luminous flux of a standard filament lamp to which the optical characteristics of a lighting device shall be referred;
- 3.1.7. Measuring luminous flux: specified value of the luminous flux for testing a filament lamp in the standard headlamp as specified in paragraph 3.8.;
- 3.1.8. Reference axis: an axis defined with reference to the cap and to which certain dimensions of the filament lamp are referred;
- 3.1.9. Reference plane: a plane defined with reference to the cap and to which certain dimensions of the filament lamp are referred.

### 3.2. General specifications

- 3.2.1. Each sample submitted shall conform to the relevant specifications of this Regulation.
- 3.2.2. Filament lamps shall be so designed as to be and to remain in good working order when in normal use. They shall moreover exhibit no fault in design or manufacture.

### 3.3. Manufacture

- 3.3.1. Filament lamp bulbs shall exhibit no scores or spots which might impair their efficiency and their optical performance.
- 3.3.2. Filament lamps shall be equipped with standard caps complying with the cap data sheets of IEC Publication 61, third edition, as specified on the individual lamp data sheets of annex 1.
- 3.3.3. The cap shall be strong and firmly secured to the bulb.
- 3.3.4. To ascertain whether filament lamps conform to the requirements of paragraphs 3.3.1. to 3.3.3. above, a visual inspection, a dimension check and, where necessary, a trial fitting shall be carried out.

### 3.4. Tests

- 3.4.1. Filament lamps shall first be aged at their test voltage for approximately one hour. For dual-filament lamps, each filament shall be aged separately.
- 3.4.2. In the case of a coloured bulb after the aging period corresponding to paragraph 3.4.1. the surface of the bulb shall be lightly wiped with a cotton cloth soaked in a mixture of 70vol.% of n-heptane and 30vol.% of toluol. After about five minutes, the surface shall be inspected visually. It must not show any apparent changes.
- 3.4.3. The position and dimensions of the filaments shall be measured with the filament lamps being supplied with current at from 90% to 100% of the test voltage.
- 3.4.4. Unless otherwise specified, electrical and photometric measurements shall be carried out at the test voltage.
- 3.4.5. Electrical measurements shall be carried out with instruments of at least class 0.2.

- 3.4.6. The luminous flux specified on the filament lamp data sheets of annex 1 is valid for filament lamps emitting white light, unless a special colour is stated there.

In the case where selective-yellow colour is allowed, the luminous flux of the filament lamp with selective-yellow outer bulb shall be at least 85% of the specified luminous flux of the relevant filament lamp with colourless bulb.

3.5. Filament position and dimensions

- 3.5.1. The geometric shapes of the filaments shall in principle be as specified on the lamp data sheets of annex 1.
- 3.5.2. For line filaments the correct position and shape shall be checked as specified in the relevant data sheets.
- 3.5.3. If the filament is shown on the lamp data sheet in at least one view as a point, the position of the luminous centre shall be determined in conformity with annex 4.
- 3.5.4. The length of a line filament shall be determined by its ends, defined - unless otherwise specified on the relevant data sheet - as the apices of the first and the last filament turn as seen in projection perpendicular to the reference axis of the lamp. Such an apex shall comply with the requirement that the angle formed by the legs shall not exceed 90 degrees . In the case of coiled-coil filaments the apices of the secondary turns shall be taken into account.
- 3.5.4.1. For axial filaments the extreme position of the apices considered shall be determined by rotating the filament lamp about its reference axis. The length shall then be measured in a direction parallel to the reference axis.
- 3.5.4.2. For transverse filaments the filament axis shall be placed perpendicular to the direction of projection. The length shall be measured in a direction perpendicular to the reference axis.
- 3.6. Colour
- 3.6.1. The bulb of the filament lamp shall be colourless,<sup>5/</sup> unless otherwise prescribed on the relevant data sheet.
- 3.6.2. The colorimetric characteristics, expressed in CIE chromaticity coordinates, shall lie within the following limits: finished filament lamps with selective yellow bulb or outer bulb
- limit towards red:  $y > 0.138 + 0.580x$ ;
- limit towards green:  $y < 1.29x - 0.100$ ;
- limit towards white:  $y > -x + 0.966$ ;  
( $y > -x + 0.940$  and  $y = 0.440$  for front fog lamps);
- limit towards spectral value:  $y < -x + 0.992$ ;
- finished filament lamps with amber bulb

---

<sup>5/</sup> A bulb is considered to be colourless if it does not appreciably alter the trichromatic coordinates of a luminous source having a colour temperature of 2,856K.

- limit towards red:  $y > 0.398$
- limit towards green:  $y < 0.429$
- limit towards white:  $z < 0.007$

3.6.3. The colour and the transmission of the bulb of filament lamps emitting coloured light shall be measured by the method specified in annex 5.

3.7. The UV radiation of a halogen filament lamp shall be such that:

$$k_1 = \frac{\int_{\lambda=315\text{nm}}^{400\text{nm}} Ee(\lambda) \cdot d\lambda}{683 \int_{\lambda=380\text{nm}}^{780\text{nm}} Ee(\lambda) \cdot V\lambda \cdot d\lambda} \leq 2 \times 10^{-4} \text{ W/lm}$$

$$k_2 = \frac{\int_{\lambda=250\text{nm}}^{315\text{nm}} Ee(\lambda) \cdot d\lambda}{683 \int_{\lambda=380\text{nm}}^{780\text{nm}} Ee(\lambda) \cdot V\lambda \cdot d\lambda} \leq 2 \times 10^{-6} \text{ W/lm}$$

where:  $Ee(\lambda)$  [W/nm] is the spectral distribution of the radiant flux;  $V(\lambda)$  [l] is the spectral luminous efficiency;  $\lambda$  [nm] is the wave length.

This value shall be calculated using intervals of five nanometre.

3.8. Observation concerning selective-yellow colour

An approval of a filament lamp type under this Regulation may be granted, pursuant to paragraph 3.6 above, for a filament lamp with a colourless as well as a selective-yellow bulb or outer bulb; article 3 of the Agreement to which this Regulation is annexed shall not prevent the Contracting Parties from prohibiting, on vehicles registered by them, lamps emitting either white or selective-yellow light.

3.9. Check on optical quality

(Applies solely to filament lamps with two filaments for headlamps emitting an asymmetrical passing beam).

3.9.1. This check of optical quality shall be carried out at a voltage such that the measuring luminous flux is obtained; the specifications of paragraph 3.4.6. are to be observed accordingly.

3.9.2. For 12V filament lamps emitting white light:

The sample which most nearly conforms to the requirements laid down for the standard filament lamp shall be tested in a standard headlamp as specified in paragraph 3.8.5. and it shall be verified whether the assembly comprising the aforesaid headlamp and the filament lamp being tested meets the light-distribution requirements laid down for the passing beam in the relevant Regulation.

3.9.3. For 6V and 24V filament lamps emitting white light: The sample which most nearly conforms to the nominal dimension values shall be tested in a

standard headlamp as specified in paragraph 3.8.5. and it shall be verified whether the assembly comprising the aforesaid headlamp and the filament lamp being tested meets the light-distribution requirements laid down for the passing-beam in the relevant Regulation. Deviations not exceeding 10% of the minimum values will be acceptable.

- 3.9.4. Filament lamps having a selective-yellow bulb or outer bulb shall be tested in the same manner as described in paragraphs 3.8.2. and 3.8.3. in a standard headlamp as specified in paragraph 3.8.5. to ensure that the illumination complies with at least 85%, for 12V filament lamps, and at least 77%, for 6V and 24V filament lamps, with the minimum values of the light-distribution requirements laid down for the passing beam in the relevant Regulation. The maximum illumination limits remain unchanged.

In the case of a filament lamp having a selective-yellow bulb this test shall be left out if the approval is also given to the same type of filament lamp emitting white light.

- 3.9.5. A headlamp shall be deemed to be a standard headlamp if:
- 3.9.5.1. it satisfies the pertinent conditions of approval;
  - 3.9.5.2. it has an effective diameter of not less than 160mm;
  - 3.9.5.3. with a standard filament lamp it produces at the various points and in the various zones specified for the headlamp type concerned, illumination equal to:
    - 3.9.5.3.1. not more than 90% of the maximum limits and
    - 3.9.5.3.2. not less than 120% of the minimum limits prescribed for the headlamp type concerned.

3.10. Standard filament lamps

Standard filament lamps for photometric tests of headlamps and light-signalling appliances are specified on the relevant data sheets of annex 1. Standard filament lamps shall have colourless bulbs (except for amber filament lamps) and be specified for only one rated voltage.

**4. CONFORMITY OF PRODUCTION**

- 4.1. Filament lamps approved to this Regulation shall be so manufactured as to conform to the type approved by meeting the inscriptions and technical requirements set forth in paragraph 3 above and annexes 1, 3 and 4 to this Regulation.
- 4.2. In order to verify that the requirements of paragraph 4.1. are met, suitable controls of the production shall be carried out.
- 4.3. The holder of the approval shall in particular:
- 4.3.1. ensure existence of procedures for the effective control of the quality of products,
  - 4.3.2. have access to the control equipment necessary for checking the conformity to each approved type,

- 4.3.3. ensure that data of test results are recorded and that related documents shall remain available for a period to be determined in accordance with the administrative service,
- 4.3.4. analyse the results of each type of test, applying criteria of annex 7, in order to verify and ensure the stability of the product characteristics making allowance for variation of an industrial production,
- 4.3.5. ensure that for each type of filament lamp, at least the tests prescribed in annex 6 to this Regulation are carried out,
- 4.3.6. ensure that any collecting of samples giving evidence of non-conformity with the type of test considered shall give rise to another sampling and another test. All the necessary steps shall be taken to re-establish the conformity of the corresponding production.
- 4.4. The competent authority which has granted type-approval may at any time verify the conformity control methods applicable to each production unit.
  - 4.4.1. In every inspection, the test books and production survey records shall be presented to the visiting inspector.
  - 4.4.2. The inspector may take samples at random which will be tested in the manufacturer's laboratory. The minimum number of samples may be determined according to the results of the manufacturer's own verification.
  - 4.4.3. When the quality level appears unsatisfactory or when it seems necessary to verify the validity of the tests carried out in application of paragraph 4.4.2. above, the inspector shall select samples, to be sent to the technical service which has conducted the type approval tests.
  - 4.4.4. The competent authority may carry out any tests prescribed in this Regulation. Where the competent authority decides to carry out spot checks, criteria of annexes 8 and 9 to this Regulation shall be applied.
  - 4.4.5. The normal frequency of inspections authorized by the competent authority shall be one every two years. In the case where negative results are recorded during one of these visits, the competent authority shall ensure that all necessary steps are taken to re- establish the conformity of production as rapidly as possible.

## **5. PENALTIES FOR NON-CONFORMITY OF PRODUCTION**

- 5.1. The approval granted in respect of a type of filament lamp pursuant to this Regulation may be withdrawn if the requirements are not met or if a filament lamp bearing the approval mark does not conform to the type approved.
- 5.2. If a Contracting Party to the Agreement applying this Regulation withdraws an approval it has previously granted, it shall forthwith so notify the other Contracting Parties applying this Regulation by means of a communication form conforming to the model in annex 2 to this Regulation.

## **6. PRODUCTION DEFINITELY DISCONTINUED**

If the holder of the approval completely ceases to manufacture a type of filament lamp approved in accordance with this Regulation, he shall so inform the authority which granted the approval. Upon receiving the



relevant communication, that authority shall inform thereof the other Parties to the 1958 Agreement applying this Regulation by means of a communication form conforming to the model in annex 2 to this Regulation.

**7. NAMES AND ADDRESSES OF TECHNICAL SERVICES RESPONSIBLE FOR CONDUCTING APPROVAL TESTS, AND OF ADMINISTRATIVE DEPARTMENTS**

The Parties to the 1958 Agreement which apply this Regulation shall communicate to the United Nations Secretariat the names and addresses of the technical services responsible for conducting approval tests and of the administrative departments which grant approval and to which forms certifying approval or extension or refusal or withdrawal of approval, or production definitely discontinued issued in other countries, are to be sent.

**8. TRANSITIONAL PROVISIONS**

8.1. Approvals granted under the preceding series of amendments shall remain valid, except that for conformity of production, current production filament lamps shall comply with the requirements of the latest series of amendments starting 12 months from the date of application of this amendment.

8.2. The correspondence between the former designations and the new ones is indicated in the following table:

Old designation	New designation in the 03 series of amendments
P25-1	P21W
P25-2	P21/5W
R19/5	R5W
R19/10	R10W
C11	C5W
C15	C21W
T8/4	T4W
W10/5	W5W
W10/3	W3W

Annex 1

**CATEGORY R2**

Sheet R2/1

The drawings are intended only to illustrate the essential dimensions of the filament lamp.

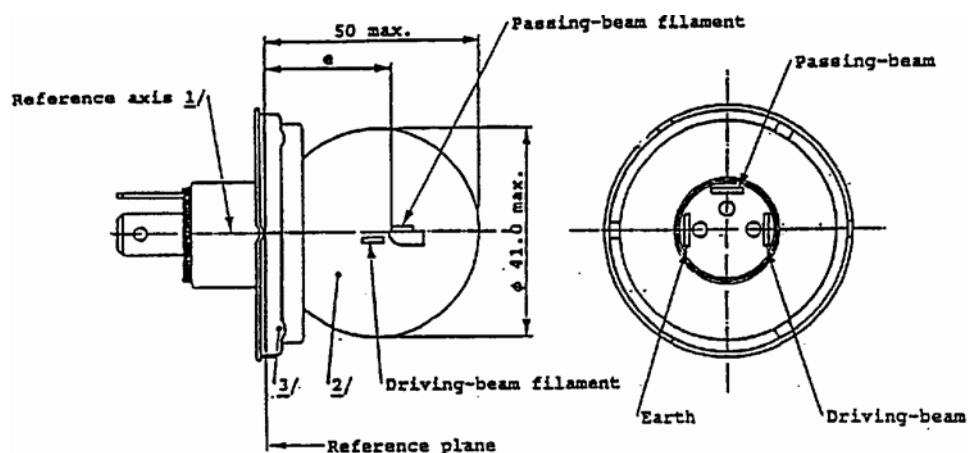

ELECTRICAL AND PHOTOMETRIC CHARACTERISTICS										
	Filament lamps of normal production								Standard filament lamp	
Rated	V	6 <sup>4/</sup>		12 <sup>4/</sup>		24 <sup>4/</sup>		12 <sup>4/</sup>		
Values	W	45	40	45	40	55	50	45	40	
Test voltage	V	6.3		13.2		28		13.2		
Objective Values	W	53 max.	47 max.	57 max.	51 max.	76 max.	69 max.	+ 0% 52 -10%	46+/- 5%	
	Luminous flux lm	720min.	570+/- 15%	860 min.	675+/- 15%	1000 min.	860+/- 15%			
Measuring flux <sup>5/</sup> lm		-	450	-	450	-	450			
Reference luminous flux at approximately 12V								700	450	

<sup>4/</sup>The values indicated on the left and on the right refer to the driving-beam filament and the passing-beam filament respectively.

<sup>5/</sup> Measuring luminous flux for measurements according to paragraph 3.8. of this Regulation.

Note: The R2 filament lamp is not recommended for new headlamp designs.

<sup>1/</sup>The reference axis is the perpendicular to the reference plane and passes through the centre of the 45mm cap diameter.

<sup>2/</sup>The bulb shall be colourless or selective-yellow.

<sup>3/</sup>No part of the cap shall, by reflection of light emitted by the passing-beam filament, throw any stray rising ray when the filament lamp is in the normal operating position on the vehicle.

**CATEGORY R2**

Sheet R2/2

**Position and dimensions of shield and filaments**

The drawings are not mandatory with respect to the design of the shield and filaments

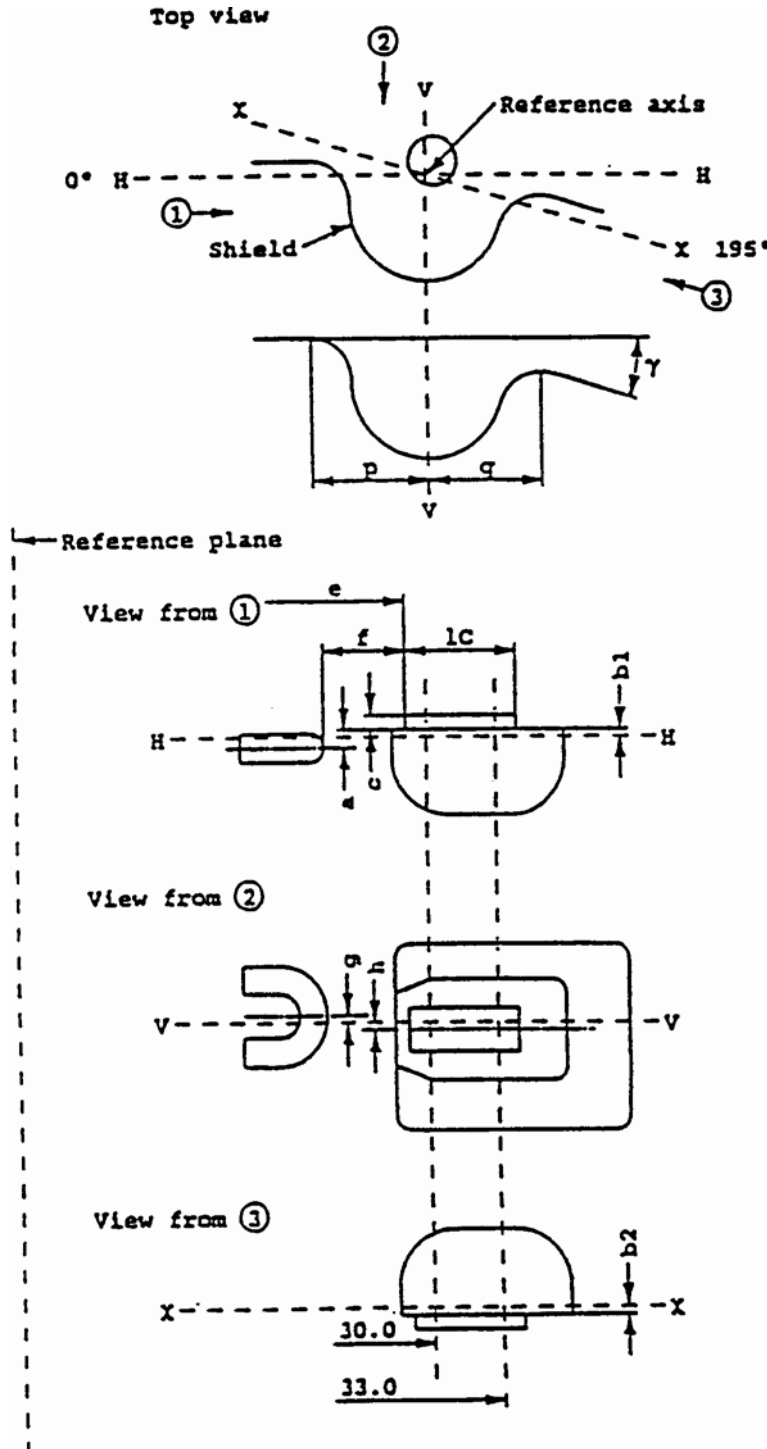

**CATEGORY R2**

Sheet R2/3

<b>FILAMENTS AND SHIELD POSITION AND DIMENSIONS</b> <sup>1/</sup>					
Dimensions in mm		Tolerance			
		Filament lamps of normal production		Standard filament lamp	
		6V	12V	24V	12V
A		0.60		+/-0.35	+/-0.15
b1/30.0	<sup>2/</sup> b1/33.0	0.20 b1/30.0mv <sup>3/</sup>		+/-0.35	+/-0.15
b2/30.0	<sup>2/</sup> b2/33.0	0.20 b2/30.0mv <sup>3/</sup>		+/-0.35	+/-0.15
c/30.0	<sup>2/</sup> c/33.0	0.50 c/30.0mv <sup>3/</sup>		+/-0.30	+/-0.15
e	6, 12V 24V	28.5 28.8		+/-0.35	+/-0.15
f	6, 12V 24V	1.8 2.2		+/-0.40	+/-0.20
G		0		+/-0.50	+/-0.30
h/30.0	<sup>2/</sup>	0 h/30mv <sup>3/</sup>		+/-0.50	+/-0.30
h/33.0	1/2 (p-q)	0		+/-0.60	+/-0.30
1c		5.5		+/-1.50	+/-0.50
gamma	<sup>4/</sup>	15 degrees nom.			

Cap P45t-41 in accordance with IEC Publ.61 (sheet 7004-95-4)

<sup>1/</sup> The position and dimensions of the shield and filaments shall be checked by means of the method of measurement as described in IEC Publication 809.

<sup>2/</sup> To be measured at the distance from the reference plane indicated in mm behind the stroke.

<sup>3/</sup> mv = measured value.

<sup>4/</sup> The angle gamma is only for shield design and has not to be checked on finished filament lamps.

**CATEGORY H1**

Sheet H1/1

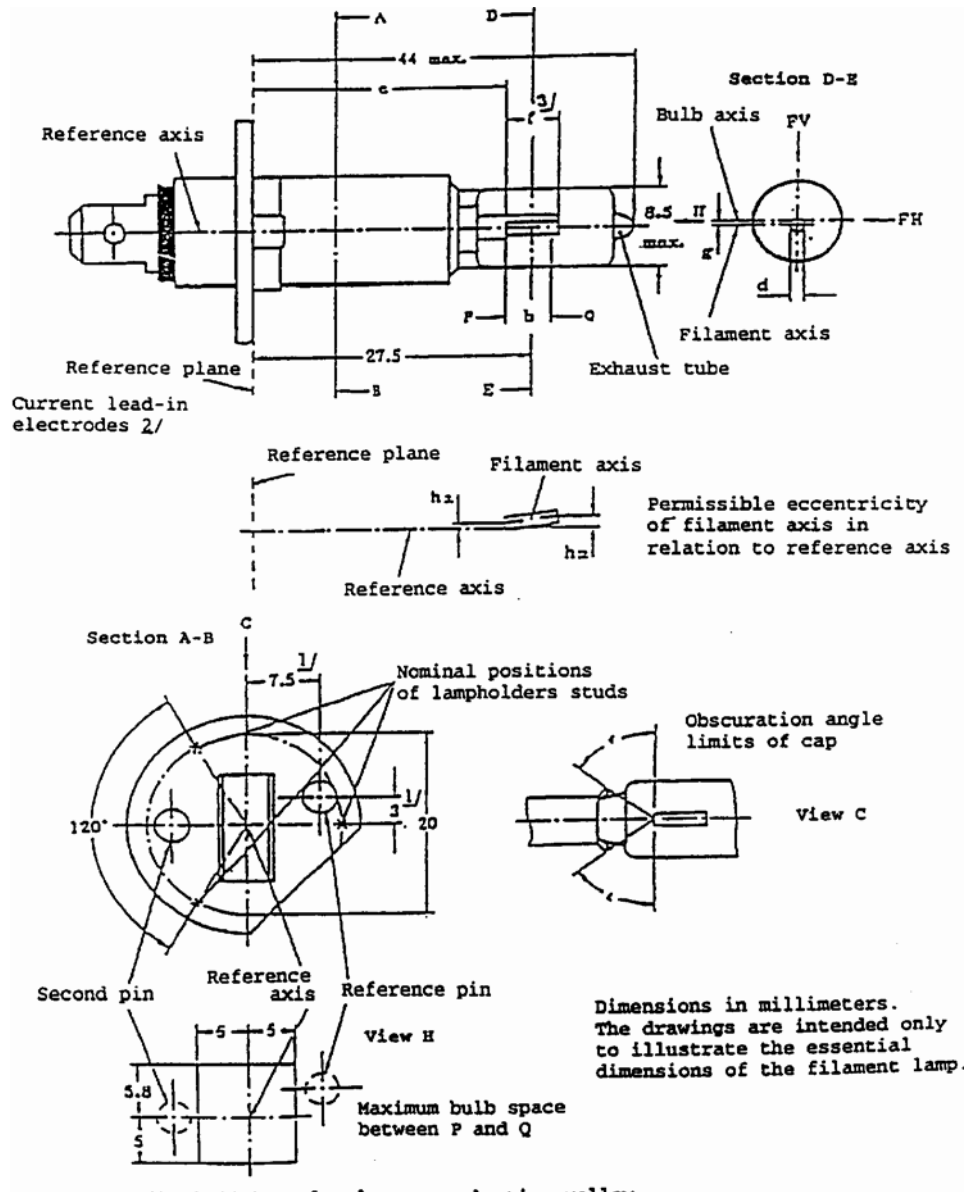

The bulb shall be colourless or selective-yellow.

**CATEGORY H1**

Sheet H1/2

Dimensions in mm		Tolerances			
		Filament lamps of normal production			Standard filament lamp
		6V	12V	24V	
b	0.7f				
e <sup>5/9/</sup>	25.0	8/			+/- 0.15
	6V	4.5	+/- 1.0		
f <sup>5/9/</sup>	12V	5.0	+/- 0.5		+ 0.5 0
	24V	5.5	+/- 1.0		
g <sup>6/</sup>	0.5 d <sup>7/</sup>		+/- 0.5 d		+/- 0.25 d
h1	0	8/			+/- 0.20 <sup>4/</sup>
h2	0	8/			+/- 0.25 <sup>4/</sup>
epsilon	45 degrees	+/- 12 degrees		+/- 3 degrees	
Cap P 14, 5s in accordance with IEC Publication 61 (Sheet 7004-46-2)					
ELECTRICAL AND PHOTOMETRIC CHARACTERISTICS					
Rated	V	6	12	24	12
values	W	55		70	55
Test voltage V		6.3	13.2	28.0	
	W	max. 63	max. 68	max. 84	max. 68 at 13.2V
Objective values	Luminous flux lm	1,350	1,550	1,900	
	+/- %	15			
Reference luminous flux for headlamp testing: 1,150lm at approx. 12V.					

---

**CATEGORY H1**

**Sheet H1/3**

- <sup>1/</sup> The reference axis is the perpendicular to the reference plane and passing through the point defined by the dimensions marked with <sup>1/</sup>.
- <sup>2/</sup> Both current lead-in electrodes shall be positioned in the bulb, the longer electrode above the filament (the lamp being viewed as shown in the figure). The internal design of the lamp should then be such that stray light images and reflections are reduced to the minimum, e.g. by fitting cooling jackets over the non-coiled parts of the filament.
- <sup>3/</sup> The cylindrical portion of the bulb over length 'f' shall be such as not to deform the projected image of the filament to such an extent as appreciably to affect the optical results.
- <sup>4/</sup> The eccentricity is measured only in the horizontal and vertical directions of the filament lamp as shown in the figure. The points to be measured are those where the projection of the outside of the end turns nearest to or furthest from the reference plane crosses the filament axis.
- <sup>5/</sup> The viewing direction is the perpendicular to the reference axis contained in the plane defined by the reference axis and the centre of the second pin of the cap.
- <sup>6/</sup> Offset of filament in relation to bulb axis measured at 27.5mm from the reference plane.
- <sup>7/</sup> d: diameter of filament.
- <sup>8/</sup> To be checked by means of a 'box-system', sheet H1/4.
- <sup>9/</sup> The ends of the filament are defined as the points where, when the viewing direction is as defined in footnote 5 above, the projection of the outside of the end turns nearest to or furthest from the reference plane crosses the reference axis (special instructions for coiled-coil filaments are under consideration).

**CATEGORY H1**

Sheet H1/4

**Screen projection requirements**

This test is used to determine, by checking whether the filament is correctly positioned relative to the reference axis and the reference plane, whether a filament lamp complies with the requirements.

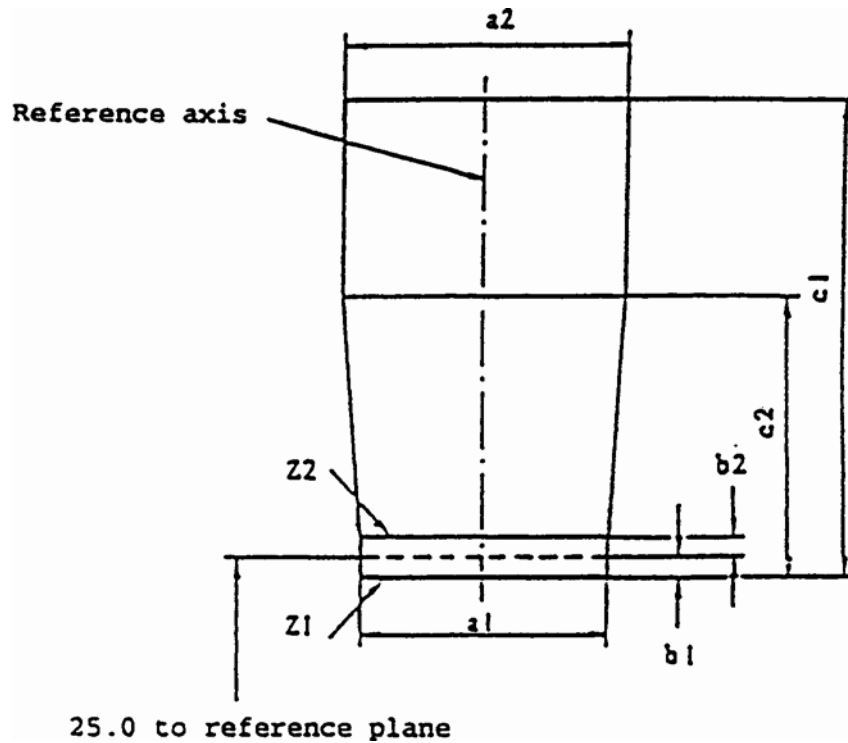

Dimensions in millimetres

	a1	a2	b1	b2	c1	c2
6V					6	3.5
12V	1.4 d	1.9 d	0.25		6	4.5
24V					7	4.5

d = diameter of filament

The beginning of the filament as defined on sheet H1/3, footnote 9/, must lie between lines Z1 and Z2. The filament position is checked solely in directions FH and FV as shown on sheet H1/1.

The filament must lie entirely within the limits shown.



**CATEGORY H2**

Sheet H2/1

The drawings are intended only to illustrate the essential dimensions of the filament lamp

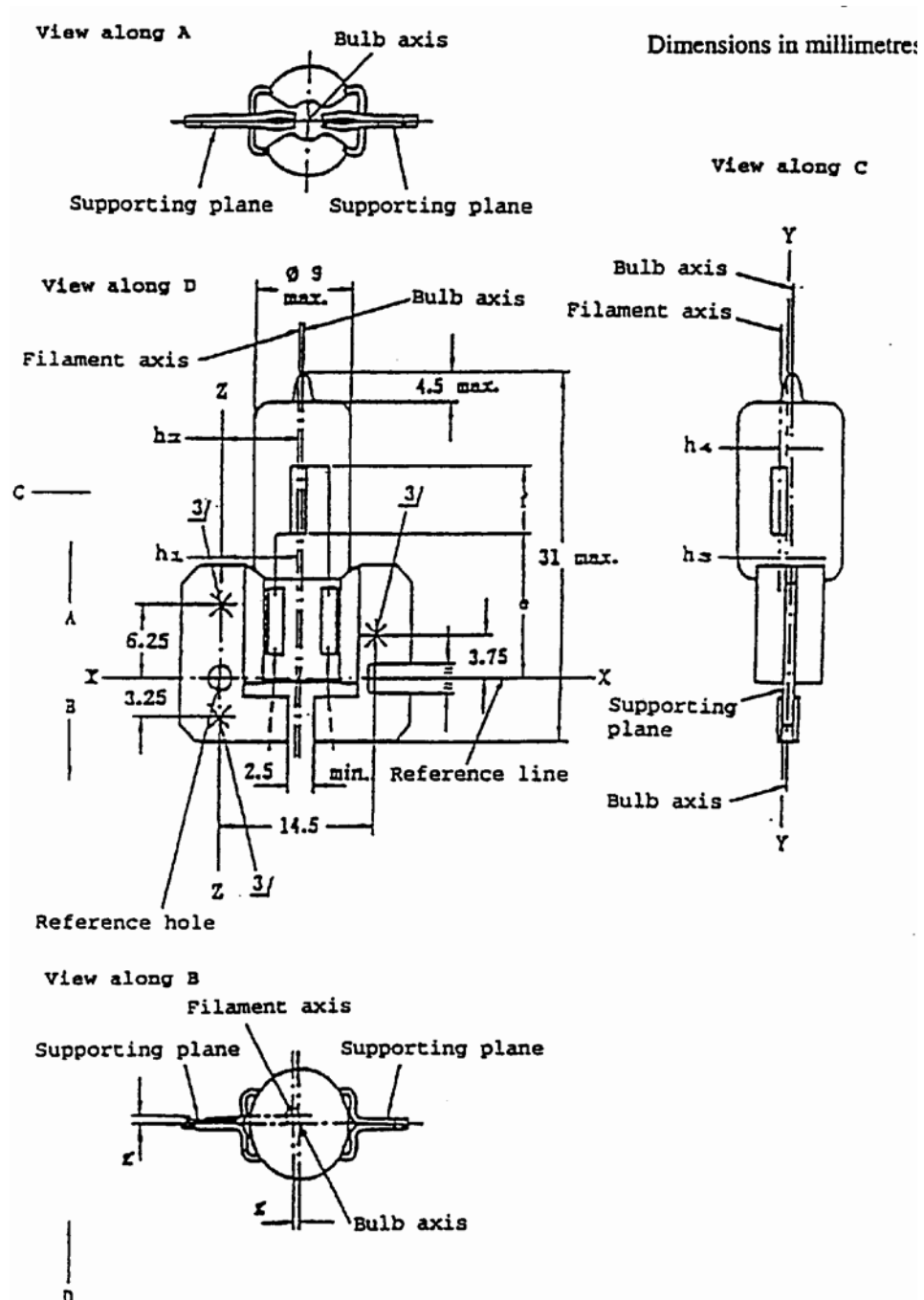

The bulb shall be colourless or selective-yellow.

**CATEGORY H2**

Sheet H2/2

Dimensions in mm		Tolerances			
		Filament lamps of normal production			Standard filament lamp
		6V	12V	24V	
e <sub>6/</sub>	12.25	5/			+/- 0.15
	6V	4.5			
f <sub>6/</sub>	12V	5.5	+/- 1.0		+/- 0.50
	24V				
g <sup>1/2/</sup>	0.5 d	+/- 0.5 d			+/- 0.25 d
h1 <sup>2/</sup>	7.1	5/			+/- 0.20
h2 <sup>4/</sup>		5/			+/- 0.25
h3 <sup>1/2/</sup>	0.5 d	5/			+/- 0.20
h4 <sup>1/4/</sup>		5/			+/- 0.25
Cap X 511 in accordance with IEC Publication 61 (sheet 7004-99-2)					
<b>ELECTRICAL AND PHOTOMETRIC CHARACTERISTICS</b>					
Rated	V	6	12	24	12
values	W	55		70	55
Test voltage	V	6.3	13.2	28.0	
	W	max. 63	max. 68	max. 84	max. 68 at 13.2V
Objective values	Luminous flux lm	1,300	1,800	2,150	
	+/- %	15			
Reference luminous flux for headlamp testing: 1,300lm at approx. 12V.					

---

**CATEGORY H2**

Sheet H2/3

- 1/ d: diameter of filament.
- 2/ These offsets should be measured in a cross-section perpendicular to the axis of the bulb and passing through that end of the filament <sup>\*/</sup> which is nearer to the cap.
- 3/ The three crosses on the supporting plane show the positions of the three bosses defining this plane on the holder. Within a circle 3mm in diameter centred on these points there should be no apparent deformation and no notches affecting the positioning of the filament lamp.
- 4/ These offsets should be measured in a cross-section perpendicular to the axis of the bulb and passing through that end of the filament <sup>\*/</sup> which is further from the cap.
- 5/ To be checked by means of a "box system", sheet H2/4.
- 6/ The ends of the filament are defined as the points where, when the viewing direction is as defined by "D" (sheet H2/1), the projection of, the outside of the end turns nearest to or furthest from the cap crosses a line parallel to and at a distance of 7.1mm from line ZZ (special instructions for coiled-coil filaments are under consideration).

---

<sup>\*/</sup>The points to be measured are those where the outside of the end turn that is nearest to or furthest from the cap crosses the filament axis.

---

**CATEGORY H2**

Sheet H2/4

**Screen projection requirements**

This test is used to determine, by checking whether a filament is correctly positioned relative to the axes x-x, y-y and z-z <sup>\*/</sup>, whether a filament lamp complies with the requirements.

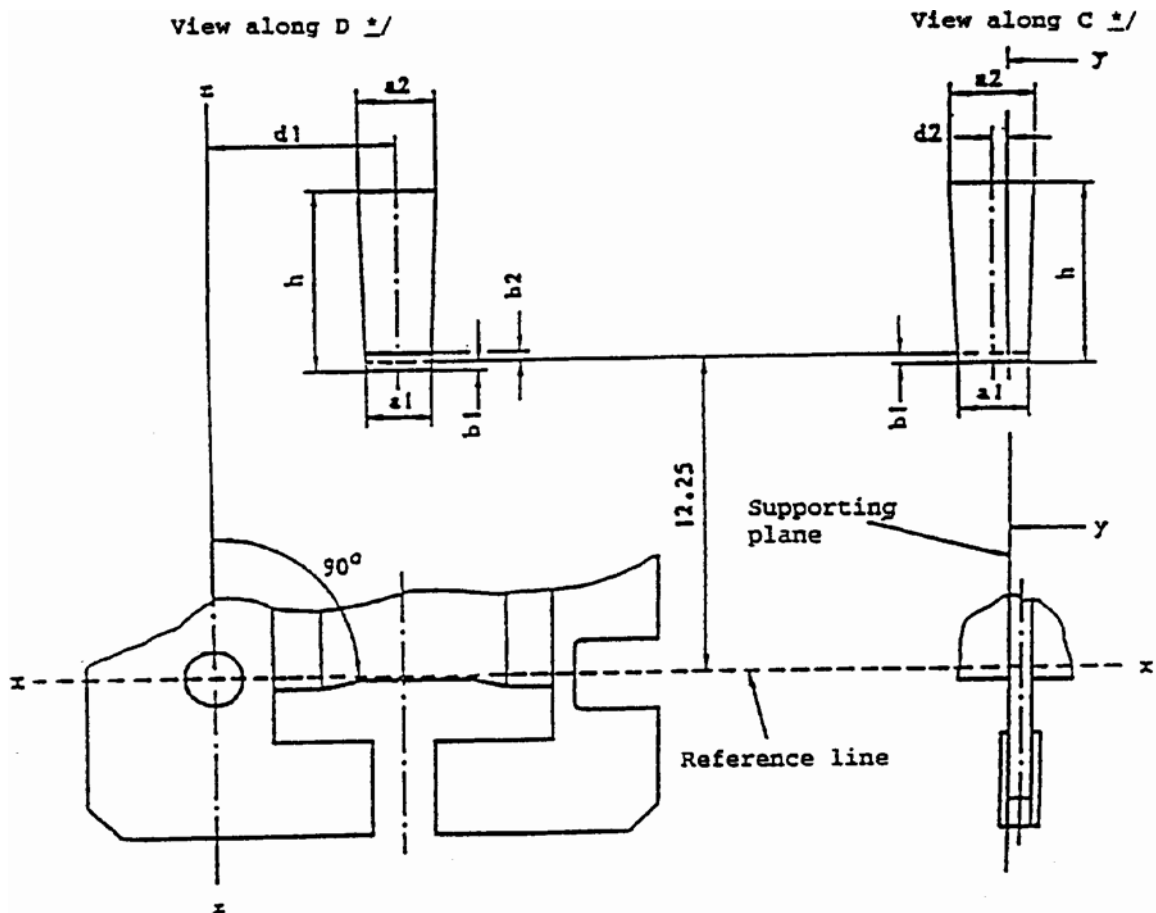

	6V	12V	24V
a1	d + 0.50		d + 1.0
a2	d + 1.0		
b1, b2	0.25		
d1	7.1		
d2	0.5d - 0.35		
h	6	7	

d = diameter of filament

The end of the filament <sup>\*\*/</sup> which is nearer to the cap must lie between b1 and b2. The filament must lie entirely within the limits shown.

<sup>\*/</sup> See sheet H2/1.

<sup>\*\*/</sup> The end of the filament is defined at sheet H2/3.

Dimensions in millimetres.

**CATEGORY H3**

Sheet H3/1

Dimensions in millimetres

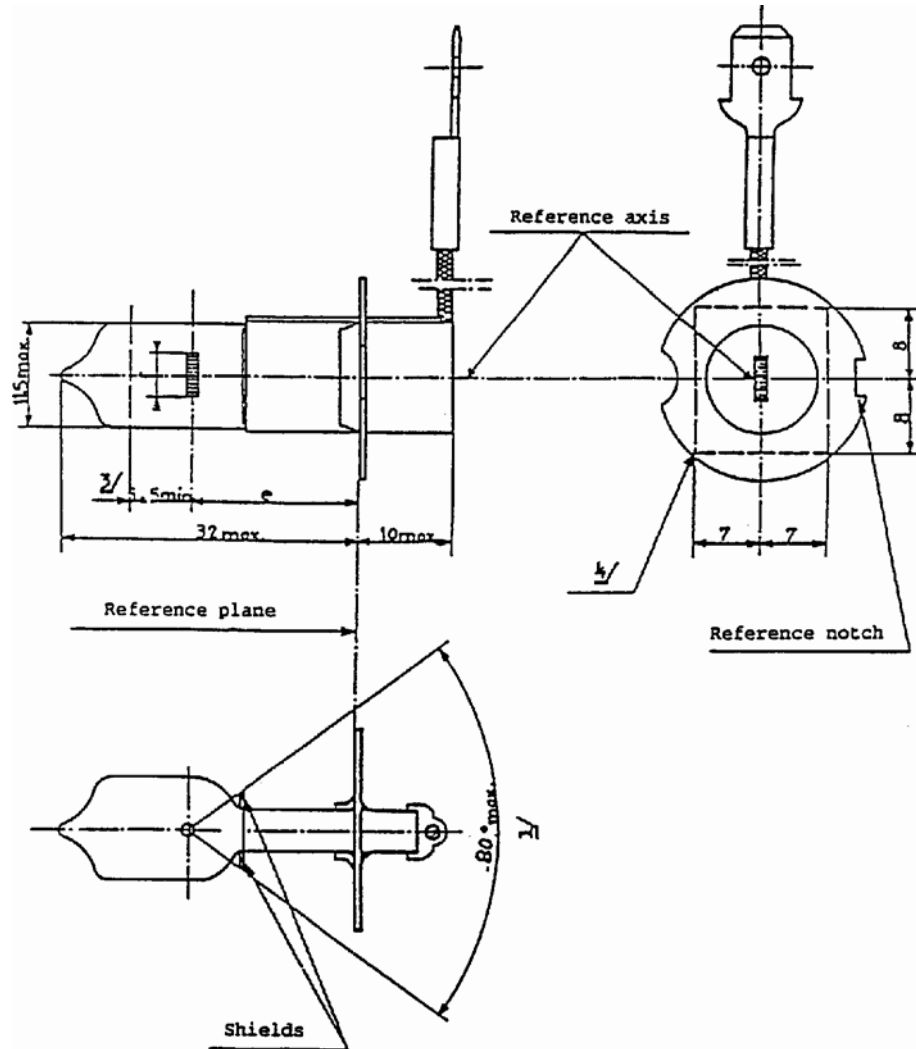

The bulb shall be colourless or selective-yellow.

**CATEGORY H3**

Sheet H3/2

Dimensions in millimetres

Definition: Ring centre and reference axis<sup>2/</sup>

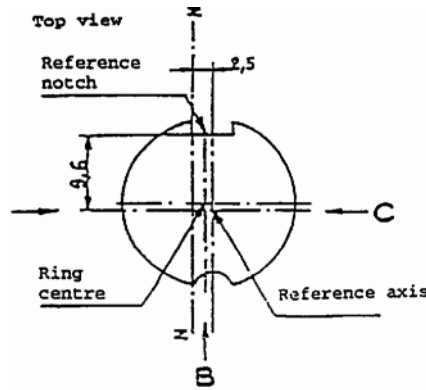

Definition of Z-Z line

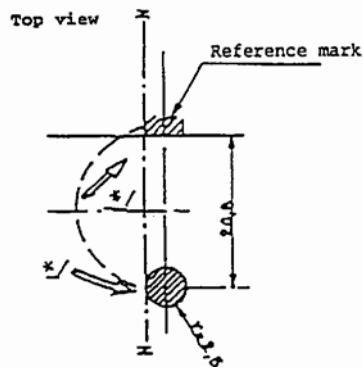

<sup>2/</sup> The cap should be pressed in these directions.

Filament dimensions and tolerances for standard filament lamps, see sheet H3/3

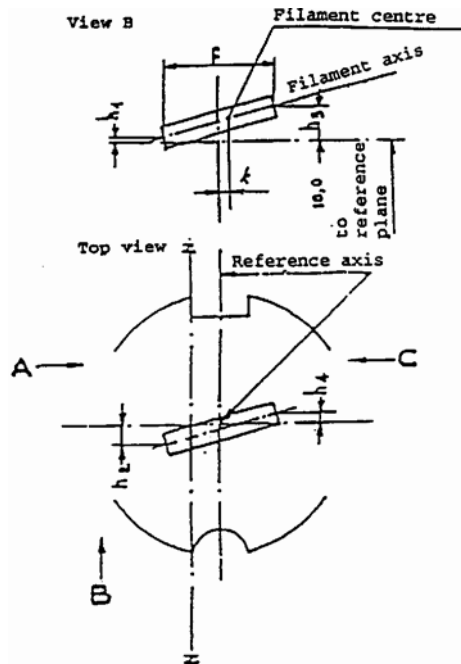

View A: measuring  $h_2$   
View B: measuring  $k$ ,  $h_1$ ,  $h_3$ ,  $f$   
View C: measuring  $h_4$

**CATEGORY H3**

Sheet H3/3

DIMENSIONS in mm			Filament lamps of normal production			Standard filament lamp		
			6V	12V	24V			
e			18.0			18.0		
f <sup>7/</sup>			3.0 min	4.0 min		5.0 +/- 0.50		
k			5/			0 +/- 0.20		
h1						0 +/- 0.15 <sup>6/</sup>		
h3								
h2								
h4						0 +/- 0.25 <sup>6/</sup>		
Cap PK 22s in accordance with IEC Publication 61 (sheet 7004-47-3)								
ELECTRICAL AND PHOTOMETRIC CHARACTERISTICS								
Rated values		V	6	12	24	12		
		W	55			70	55	
Test voltage		V	6.3	13.2	28.0			
Objective values		W	max. 63	max. 68	max. 84	max. 68 at 13.2V		
	Luminous flux	lm	1,050	1,450	1,750			
		+/- %	15					
Reference luminous flux for headlamp testing, 1,100lm at approx. 12V								



---

**CATEGORY H3**

sheet H3/4

- 1/ The distortion of the base-end portion of the bulb must not be visible from any direction outside the obscuration angle of 80 degrees max. The shields must produce no inconvenient reflections. The angle between the reference axis and the plane of each shield, measured on the bulb side, should not exceed 90 degrees .
- 2/ The permissible deviation of the ring centre from the reference axis is 0.5mm in the direction perpendicular to the Z-Z line and 0.05mm in the direction parallel to the Z-Z line.
- 3/ Minimum length above the height of the light-emitting centre ("e") over which the bulb must be cylindrical.
- 4/ No part of the spring and no component of the lamp-holder shall bear on the prefocus ring elsewhere than outside the rectangle shown in discontinuous outline.
- 5/ These dimensions of lamps of normal production should be checked by means of a "box system" sheet H3/5
- 6/ For standard filament lamps the points to be measured are those where the projection of the outside of the end turns crosses the filament axis.
- 7/ The positions of the first and the last turn of the filament are defined by the intersections of the outside of the first and the outside of the last light-emitting turn, respectively, with the plane parallel to and 18mm distant from the reference plane (additional instructions for coiled-coil filaments are under consideration).

**CATEGORY H3**

Sheet H3/5

**Screen Projection Requirements**

This test is used to determine, by checking whether the filament is correctly positioned relative to the reference axis and the reference plane, whether a filament lamp complies with the Requirements.

dimensions in millimetres

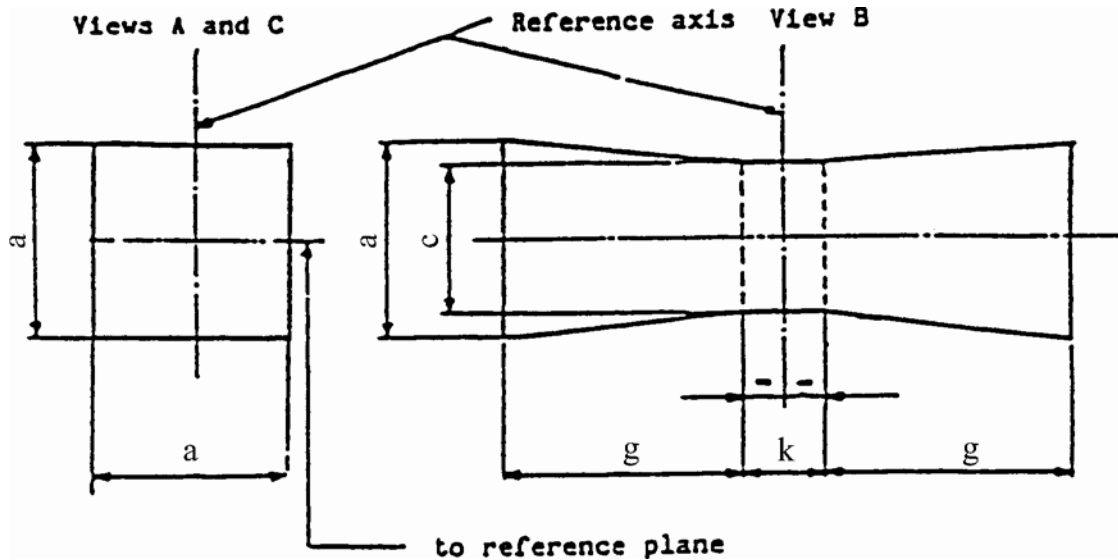

	a	c	k	g
6 V	1.8d	1.6d	1.0	2.0
12 V				2.8
24 V				2.9

d = diameter of the filament

The filament shall lie entirely within the limits shown.

The centre of the filament shall lie within the limits of dimension k.

**CATEGORY H3**

Sheet H3/6

Screen Projection Requirements

This test is used to determine, by checking whether the filament is correctly positioned relative to the reference axis and the reference plane, whether a filament lamp complies with the requirements.

dimensions in mm

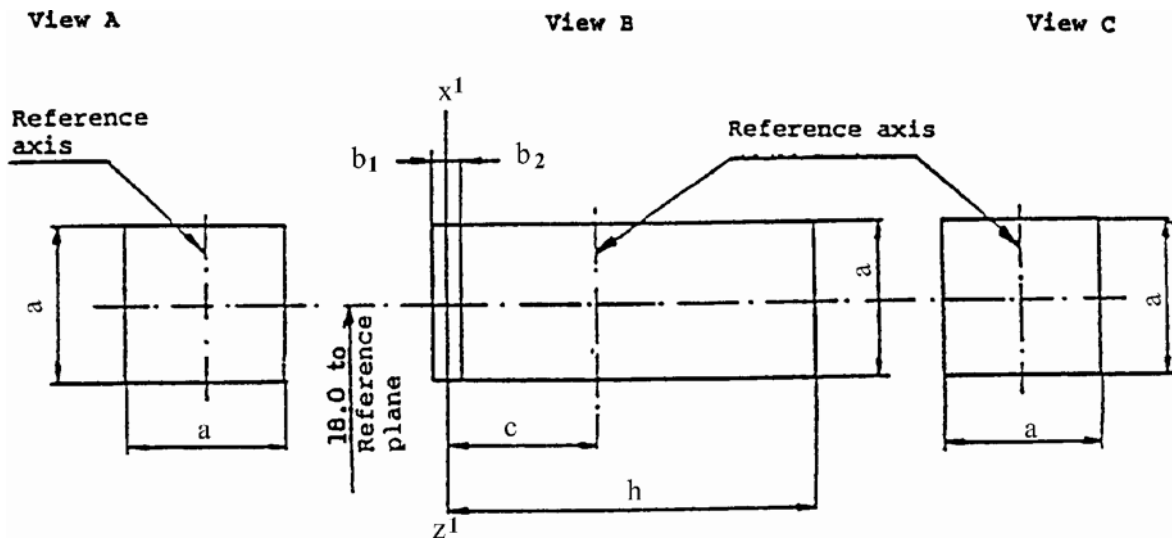

	a	b	b	c	h
6V	1.8d	1	2	2.0	4.6
12V	1.8d	0.25		2.5	6.0
24V	1.8d				6.2

d = diameter of filament

The first turn of the filament must lie entirely within the limits shown in view "A". The transverse projection of the filament must lie within the limits shown in view "B"; z'-z' is a plane perpendicular to the reference plane, parallel to and on the same side as the z-z line and at a distance "c" from the reference axis. The beginning of the filament as defined will be between b<sub>1</sub> and b<sub>2</sub>. The last turn of the filament <sup>\*/</sup> will be within the limits shown in view "C".

<sup>\*/</sup> as defined on sheet H3/4, footnote 7.

**CATEGORY H3**

Sheet H4/1

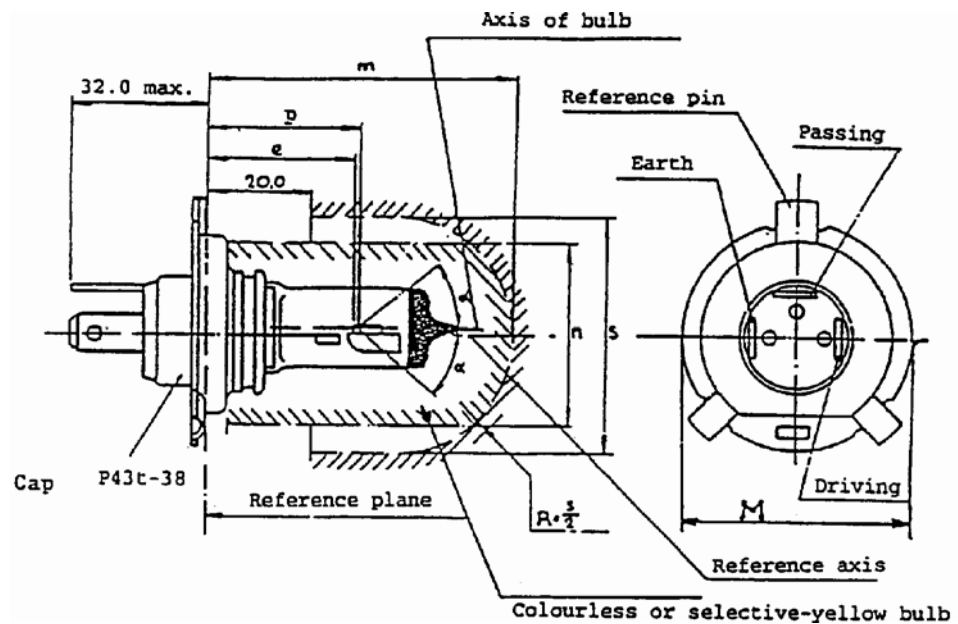

(Dimensions in mm)

The drawings are not mandatory; their sole purpose is to show which dimensions must be verified.

Reference	Dimension		Tolerance	
	12 V	24 V	12 V	24 V
e	28.5	29.0	+ 0.45 - 0.25	+/- 0.35
p	28.95	29.25	-	-
m <sup>1/</sup>	max. 60.0		-	
n <sup>1/</sup>	max. 34.5		-	
s <sup>2/</sup>	45.0		-	
alpha <sup>3/</sup>	max. 40 degrees		-	

<sup>1/</sup> Where a yellow outer bulb is used, "m" and "n" denote the maximum dimensions of this bulb; where there is no outer bulb, "m" denotes the maximum length of the lamp.

<sup>2/</sup> It must be possible to insert the lamp into a cylinder of diameter "s" concentric with the reference axis and limited at one end by a plane parallel to and 20mm distant from the reference plane and at the other end by a hemisphere of radius s/2.

<sup>3/</sup> The obscuration must extend at least as far as the cylindrical part of the bulb. It must also overlap the internal shield when the latter is viewed in a direction perpendicular to the reference axis. The effect sought by obscuration may also be achieved by other means.

**CATEGORY H4**

Sheet H4/2

**Characteristics**

Filament lamps of normal production						Standard filament lamp	
Rated	V	12 <sup>4/</sup>		24 <sup>4/</sup>		12 <sup>4/</sup>	
values	W	60	55	75	70	60	55
Test voltage	V	13.2		28			
Objective values	W	max. 75	max. 68	max. 85	max. 80	max. 75 at 13.2	max. 68 at 13.2V
	Luminous flux lm	1,650	1,000	1,900	1,200		
	+/- %	15					
Measuring luminous flux according to para. 3.8. of this Regulation	lm		750		800		
Reference luminous flux at approximately 12Vlm						1,250	750
Cap P43t-38 in accordance with IEC Publication 61 (sheet 7004-39-5)							

<sup>4/</sup> The values indicated in the left-hand column relate to the driving beam. Those indicated in the right-hand column relate to the passing beam.

**CATEGORY H4**

Sheet H4/3

Position of shield <sup>\*/</sup>

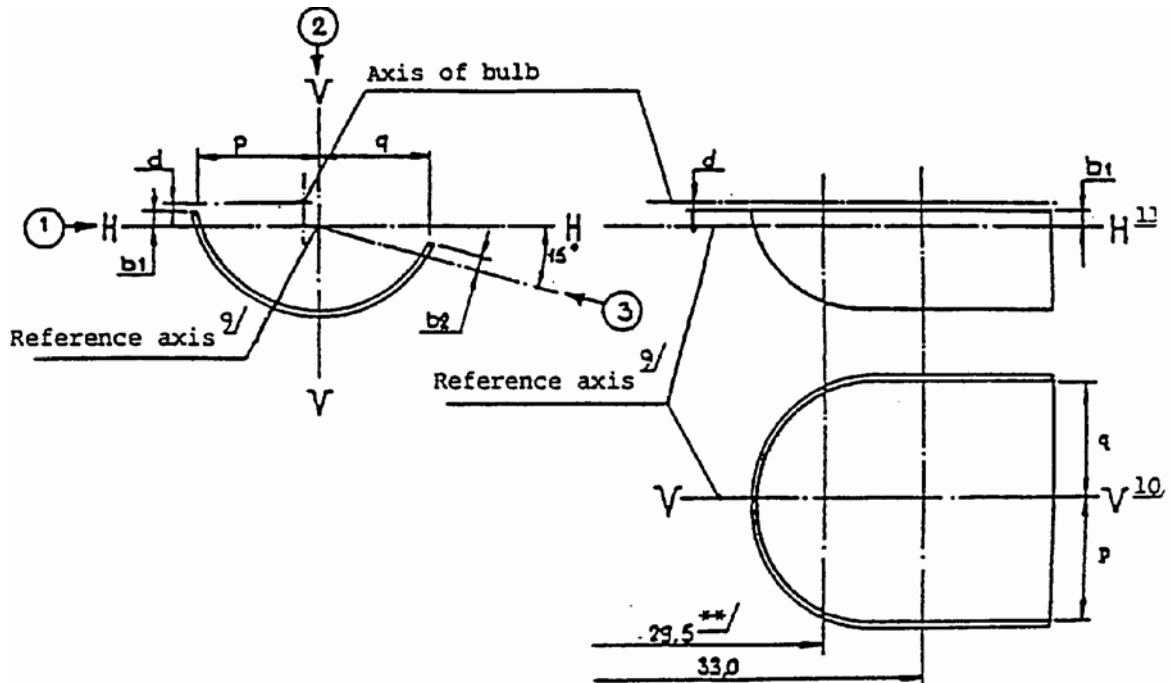

<sup>\*/</sup> The drawing is not mandatory with respect to the design of the shield.

<sup>\*\*</sup> 30.0 for the 14V type.

**CATEGORY H4**

Sheet H4/4

Position of filaments <sup>\*/</sup>

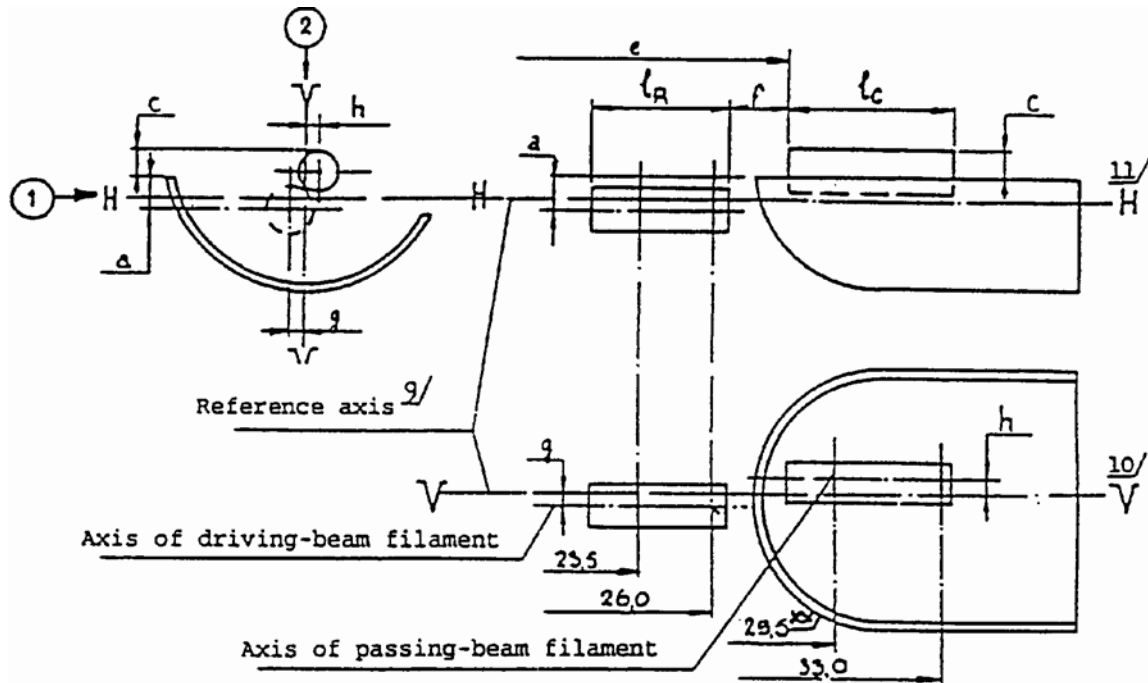

Dimensions in mm

<sup>\*/</sup> The drawing is not mandatory with respect to the design of the shield.

<sup>\*\*</sup> 30.0 for the 14V type.

---

**CATEGORY H4**

Sheet H4/5

**Additional explanations to sheets H4/3 and H4/4** The dimensions below are measured in three directions:

- (1) for dimensions a, b<sub>1</sub>, c, d, e, f, l<sub>R</sub> and l<sub>C</sub>;
  - (2) for dimensions g, h, p and q;
  - (3) for dimensions b<sub>2</sub>.
- Dimensions p and q are measured in a plane parallel to and 33mm away from the reference plane.
- Dimensions b<sub>1</sub>, b<sub>2</sub>, c and h are measured in planes parallel to and 29.5mm (30.0mm for 24V lamps) and 33mm away from the reference plane.
- Dimensions a and g are measured in planes parallel to and 26.0mm and 23.5mm away from the reference plane.

Note: For the method of measurement, see Appendix E of IEC Publication 809.



**CATEGORY H4**

Sheet H4/6

**Table of the dimensions referred to in the diagrams on sheet H4/3 and H4/4 (in mm)**

Reference		Dimension		Tolerances		
				Filament lamps of normal production		Standard filament lamp
12V	24V	12V	24V	12V	24V	12V
a/26 <sup>*/</sup>		0.8		+/- 0.35		+/- 0.2
a/23.5 <sup>*/</sup>		0.8		+/- 0.60		+/- 0.2
b1/29.5 <sup>*/</sup>	30.0 <sup>*/</sup>	0		+/- 0.30	+/- 0.35	+/- 0.2
b1/33 <sup>*/</sup>		b1/29.5mv <sup>**/</sup>	30.0mv <sup>**/</sup>	+/- 0.30	+/- 0.35	+/- 0.15
b2/29.5 <sup>*/</sup>	30.0 <sup>*/</sup>	0		+/- 0.30	+/- 0.35	+/- 0.2
b2/33 <sup>*/</sup>		b2/29.5mv <sup>**/</sup>	30.0mv <sup>**/</sup>	+/- 0.30	+/- 0.35	+/- 0.15
c/29.5 <sup>*/</sup>	30.0 <sup>*/</sup>	0.6	0.75	+/- 0.35		+/- 0.2
c/33 <sup>*/</sup>		c/29.5mv <sup>**/</sup>	30.0mv <sup>**/</sup>	+/- 0.35		+/- 0.15
d		min. 0.1		-		-
e <sup>7/</sup>		28.5	29.0	+ 0.35 - 0.25	+/- 0.35	+ 0.2 - 0.0
f <sup>5/ 6/ 8/</sup>		1.7	2.0	+ 0.50 - 0.30	+/- 0.40	+ 0.3 - 0.1
g/26 <sup>*/</sup>		0		+/- 0.5		+/- 0.3
g/23.5 <sup>*/</sup>		0		+/- 0.7		+/- 0.3
h/29.5 <sup>*/</sup>	30.0 <sup>*/</sup>	0		+/- 0.5		+/- 0.3
h/33 <sup>*/</sup>		h/29.5mv <sup>**/</sup>	30.0mv <sup>**/</sup>	+/- 0.35		+/- 0.2
1R <sup>5/ 8/</sup>		4.5	5.25	+/- 0.8		+/- 0.4
1c <sup>5/ 6/</sup>		5.5	5.25	+/- 0.5	+/- 0.8	+/- 0.35
p/33 <sup>*/</sup>		Depends on the shape of the shield		-		-
q/33 <sup>*/</sup>		$\frac{p+q}{2}$		+/- 0.6		+/- 0.3

<sup>\*/</sup> Dimension to be measured at the distance from the reference plane indicated in mm after the stroke.

<sup>\*\*/</sup> "29.5mv" or "30.0mv" means the value measured at a distance of 29.5mm or 30.0mm from the reference plane.

---

**CATEGORY H4**

**Sheet H4/7**

- 5/ The end turns of the filaments are defined as being the first luminous turn and the last luminous turn that are at substantially the correct helix angle. For coiled-coil filaments, the turns are defined by the envelope of the primary coil.
- 6/ For the passing-beam filament the points to be measured are the intersections, seen in direction (1), of the lateral edge of the shield with the outside of the end turns defined under foot-note 5.
- 7/ "e" denotes the distance from the reference plane to the beginning of the passing-beam filament as defined above.
- 8/ For the driving-beam filament the points to be measured are the intersections, seen in direction (1), of a plane, parallel to plane HH and situated at a distance of 0.8mm below it, with the end turns defined under foot-note 5.
- 9/ The reference axis is the line perpendicular to the reference plane and passing through the centre of the circle of diameter "M" (see sheet H4/1)
- 10/ Plane VV is the plane perpendicular to the reference plane and passing through the reference axis and through the intersection of the circle of diameter "M" with the axis of the reference pin.
- 11/ Plane HH is the plane perpendicular to both the reference plane and plane VV and passing through the reference axis.

**CATEGORY P21W**

Sheet P21W/1

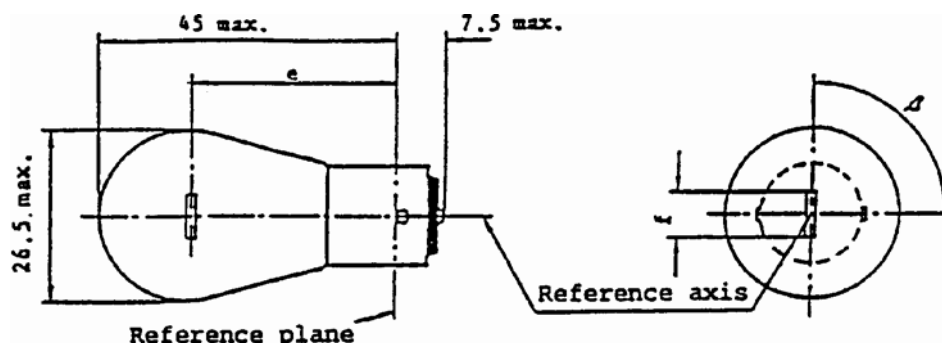

Dimensions in mm		Filament lamps of normal production			Standard filament lamp
		min.	nom.	max.	
e			31.8 <sup>3/</sup>		31.8 +/- 0.3
f	12 V	5.5	6.0	7.0	6.0 +/- 0.5
	6, 24 V <sup>4/</sup>			7.0	
Beta		75 degrees	90 degrees	105 degrees	90 degrees +/- 5 degrees
Lateral deviation <sup>1/</sup>				3/	0.3 max.
Cap BA 15s in accordance with IEC Publication 61 (sheet 7004-11A-8) Lamps with cap BA 15d may be used for special purposes; they have the same dimensions <sup>2/</sup>					
<b>ELECTRICAL AND PHOTOMETRIC CHARACTERISTICS</b>					
Rated values	V	6	12	24	12
	W	21			21
Test voltage	V	6.75	13.5	28.0	
Objective values	W +/- %	26	25	28	25 at 13.5V
		6			6
	Luminous flux lm +/- %	460			
		15			
Reference luminous flux: 460lm at approximately 13.5V					

<sup>3/</sup>To be checked by means of a "box system", sheet P21W/2

<sup>4/</sup> For 24V heavy-duty lamps having a different filament shape, additional specifications are under consideration.

<sup>1/</sup> Maximum lateral deviation of filament centre from two reciprocally perpendicular planes both containing the reference axis of cap and one containing axis of pins.

<sup>2/</sup>Lamps with cap BA 15d may be used for special purposes; they have the same dimensions.

**CATEGORY P21W**

Sheet P21W/2

Screen projection requirements

This test is used to determine, by checking whether the filament is correctly positioned relative to the reference axis and the reference plane and has an axis perpendicular, within +/- 15 degrees, to the plane through the centres of the pins and the reference axis, whether a filament lamp complies with the requirements.

Dimensions in mm

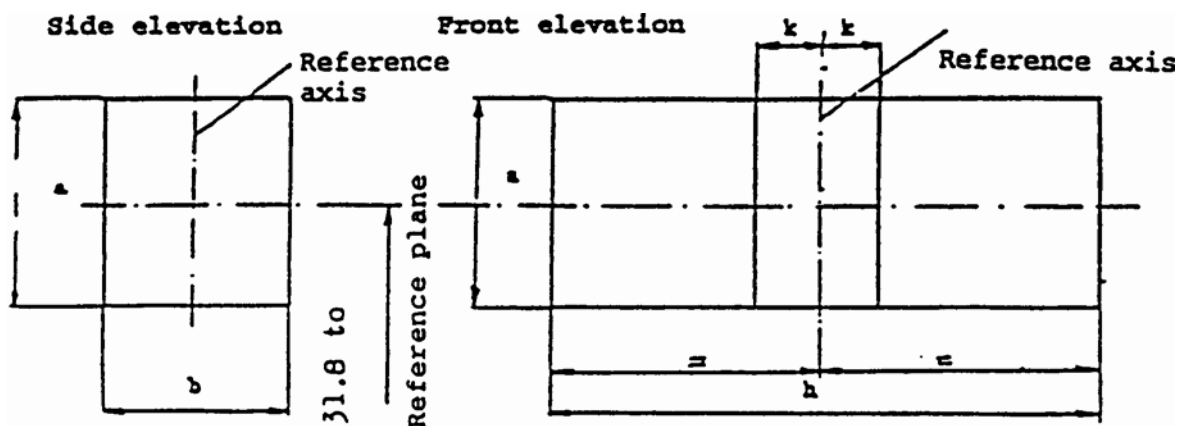

reference	a	b	h	k
dimension	3.5	3.0	9.0	1.0

Test procedure and requirements.

1. The lamp is placed in a holder (socket) capable of being rotated about its axis and having either a calibrated scale or fixed stops corresponding to the angular-displacement tolerance limits, i.e. +/- 15 degrees . The holder is then so rotated that an end view of the filament is seen on the screen on to which the image of the filament is projected. The end view of the filament should be obtained within the angular-displacement tolerance limits (+/- 15 degrees ).

2. **Side elevation**

The lamp being placed with the cap down, the reference axis vertical, and the filament seen end-on, the projection of the filament should lie entirely within a rectangle of height "a" and width "b" having its centre at the theoretical position of the centre of the filament.

3. **Front elevation**

The lamp being placed with the cap down and the reference axis vertical, the lamp being viewed in a direction at right angles to the filament axis:

- 3.1. the projection of the filament should lie entirely within a rectangle of height "a" and width "h" centred on the theoretical position of the centre of the filament; and
- 3.2. the centre of the filament should not be offset by more than the distance "k" from the reference axis.

**CATEGORY P21/4W**

Sheet P21/4W/1

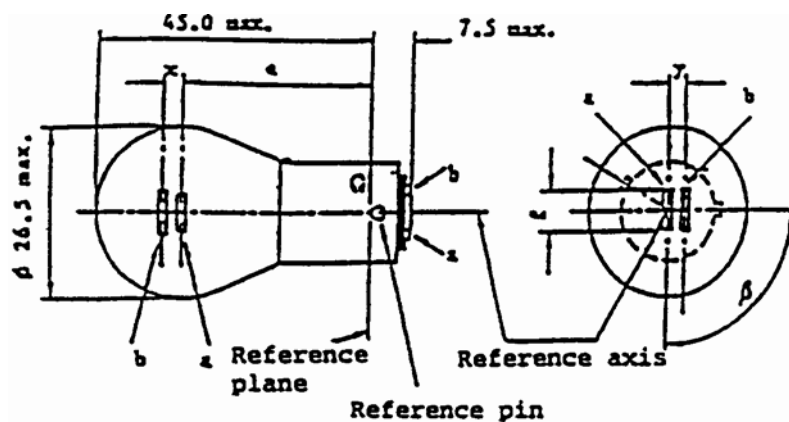

- (a) Main (high-wattage) filament
- (b) Auxiliary (low-wattage) filament

Dimensions in mm	Lamps of normal production			Standard filament lamp		
	min.	nom.	max.			
e		31.8 <sup>1/</sup>		31.8 +/- 0.3		
f			7.0 <sup>1/</sup>	7.0	+0 -2	
Lateral deviation			1/	0.3 max. <sup>2/</sup>		
x, y	1/			2.8 +/- 0.5		
beta	75 degrees <sup>1/</sup>	90 degrees <sup>1/</sup>	105 degrees <sup>1/</sup>	90 degrees +/- 5 degrees		
Cap BAZ 15d in accordance with IEC Publication 61 (sheet 7004-11C-1)						
<b>ELECTRICAL AND PHOTOMETRIC CHARACTERISTICS</b>						
Rated values	V	12		12		
	W	21	4	21	4	21/4
Test voltage	V	13.5		28		
Objective values	W	25	5	28	8	25/5 at 13.5V
	+/- %	6	10	6	10	6 and 10
	Luminous flux lm	440	15	440	20	
	+/- %	15	20	15	20	
Reference luminous flux: 440lm and 15lm at approximately 13.5V						

<sup>1/</sup> These dimensions should be checked by means of a "box system" <sup>\*/</sup> based on the dimensions and tolerances shown above. "x" and "y" refer to the main (high wattage) filament, not to the lamp axis. Means of increasing

<sup>\*/</sup> The "box-system" is the same as for filament lamp P21/5W.

the positioning accuracy of the filament and of the cap-holder assembly are under consideration.

<sup>2/</sup> Maximum lateral deviation of main filament centre from two reciprocally perpendicular planes both containing reference axis and one containing axis of pins.

**CATEGORY P21/5W**

Sheet P21/5W/1

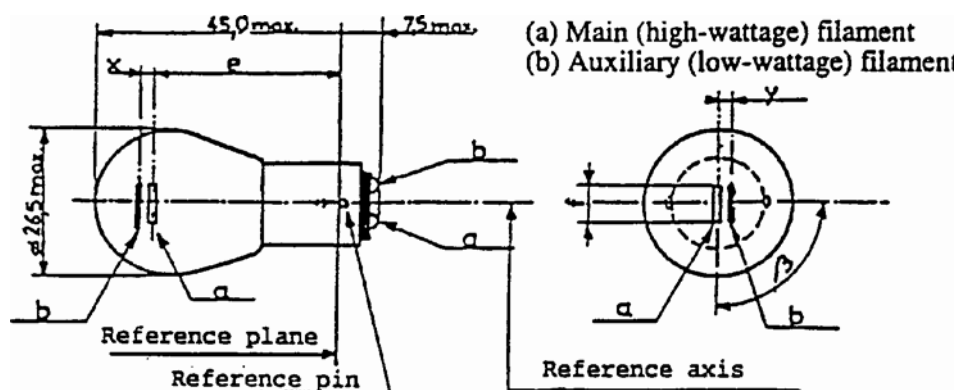

Dimensions in mm	Lamps of normal production			Standard filament lamp				
	min.	nom.	max.					
e		31.8 <sup>1/</sup>		31.8 +/- 0.3				
f			7.0 <sup>1/</sup>	7.0 -0 -2				
Lateral deviation			1/	0.3 max. <sup>2/</sup>				
x, y	1/			2.8 +/- 0.3				
Beta	75 degrees <sup>1/</sup>	90 degrees	105 degrees <sup>1/</sup>	90 degrees +/- 5 degrees				
Cap BAY 15d in accordance with IEC Publication 61 (sheet 7004-11B-7)								
<b>ELECTRICAL AND PHOTOMETRIC CHARACTERISTICS</b>								
Rated values	V	6		12		24		12
	W	21	5	21	5	21 <sup>3/</sup>	5	21/5
Test voltage	V	6.75		13.5		28.0		
Objective values	W	26	6	25	6	28	10	25 and 6 at 13.5V
	+/- %	6	10	6	10	6	10	6 and 10
	Luminous flux lm	440	35	440	35	440	40	
	+/- %	15	20	15	20	15	20	
Reference luminous flux: 440lm at 35lm at approximately 13.5V								

<sup>1/</sup> These dimensions should be checked by means of a "box system" (P21/5W/2, P21/5W/3) based on the dimensions and tolerances shown above. "x" and "y" refer to the main (high-wattage) filament, not to the lamp axis (P21/5W/2). Means of increasing the positioning accuracy of the filament and of the cap-holder assembly are under consideration.

<sup>2/</sup> Maximum lateral deviation of main (high-wattage) filament centre from two mutually perpendicular planes both containing reference axis and one containing axis of pins.

<sup>3/</sup> The 24V filament lamp is not recommended for future embodiments.

---

**CATEGORY P21/5W**

Sheet P21/5W/2

Screen projection requirements

This test is used to determine, by checking whether:

- (a) the main (high-wattage) filament is correctly positioned relative to the reference axis and the reference plane and has an axis perpendicular, within +/- 15 degrees, to the plane through the centres of the pins and the reference axis; and whether
- (b) the auxiliary (low-wattage) filament is correctly positioned relative to the main (high-wattage) filament,

whether a filament lamp complies with the requirements. Test procedure and requirements

1. The lamp is placed in a holder (socket) capable of being rotated about its axis and having either a calibrated scale or fixed stops corresponding to the angular-displacement tolerance limits, i.e. +/- 15 degrees. The holder is then so rotated that an end view of the main (high-wattage) filament is seen on the screen onto which the image of the filament is projected. The end view of the main (high-wattage) filament should be obtained within the angular-displacement tolerance limits (+/- 15 degrees).

2. **Side elevation**

The lamp being placed with the cap down, the reference axis vertical, the reference pin to the right and the main (high-wattage) filament seen end-on:

- 2.1. the projection of the main (high-wattage) filament should lie entirely within a rectangle of height "a" and width "b" having its centre at the theoretical position of the centre of the filament.
- 2.2. the projection of the auxiliary (low-wattage) filament should lie entirely:
  - 2.2.1. within a rectangle of width "c" and height "d" having its centre at a distance "v" to the right of and at a distance "u" above the theoretical position of the centre of the main (high-wattage) filament;
  - 2.2.2. above a straight line tangential to the upper edge of the projection of the main (high-wattage) filament and rising from left to right at an angle of 25 degrees;
  - 2.2.3. to the right of the projection of the main (high-wattage) filament.

3. **Front elevation**

The lamp being placed with the cap down and the reference axis vertical, the lamp being viewed in a direction at right angles to the axis of the main (high-wattage) filament:

- 3.1. the projection of the main (high-wattage) filament should lie entirely within a rectangle of height "a" and width "h" centred on the theoretical position of the centre of the filament;
- 3.2. the centre of the main (high-wattage) filament should not be offset by more than the distance "k" from the reference axis;
- 3.3. the centre of the auxiliary (low-wattage) filament shall not be offset from the reference axis by more than +/- 2mm (+/- 0.4mm for standard filament lamps).



**CATEGORY P21/5W**

Sheet P21/5W/3  
 Dimensions in mm

**Side elevation**

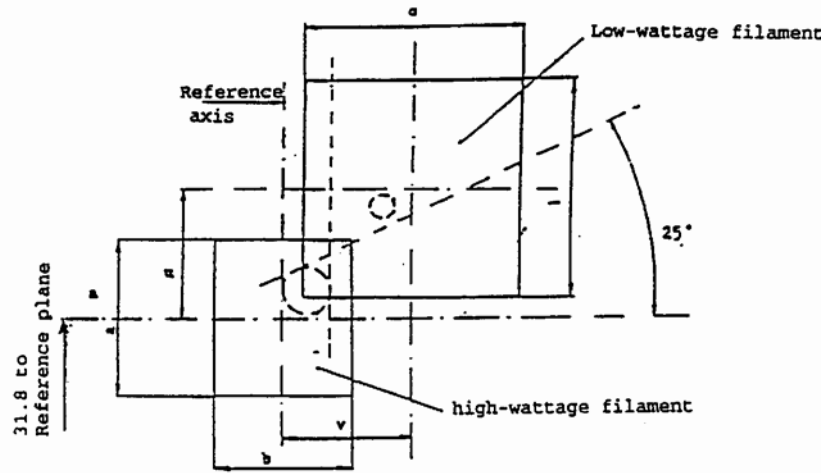

Reference	a	b	c	d	u	v
Dimensions	3.5	3.0	4.8		2.8	

**Front elevation**

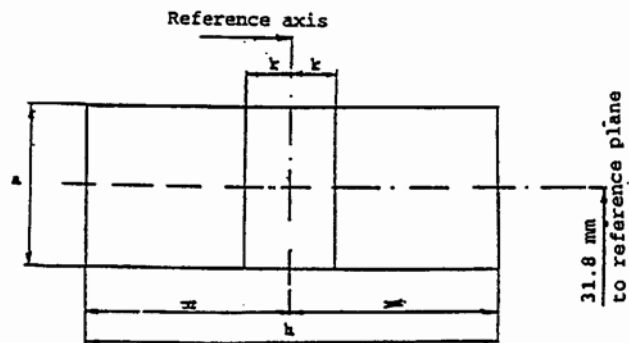

Reference	a	h	k
Dimension	3.5	9.0	1.0

**CATEGORY R5W**

Sheet R5W/1

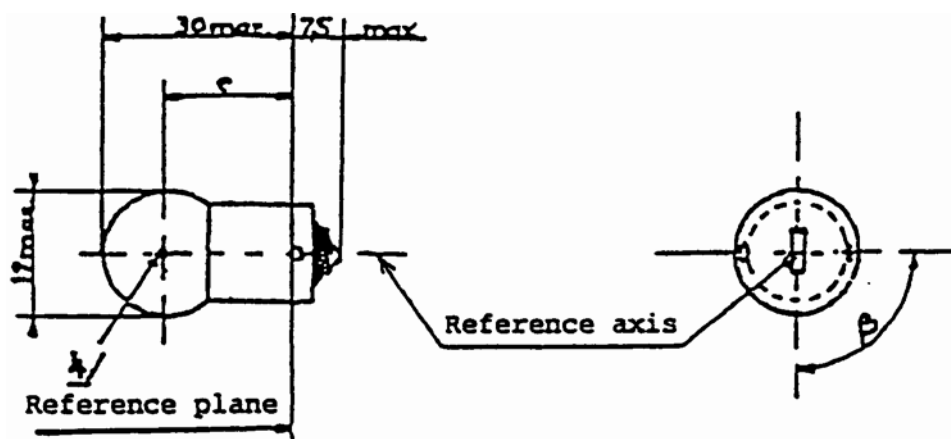

Dimensions in mm	Filament lamps of normal production			Standard filament lamp	
	min.	nom.	max.		
e	17.5	19.0	20.5	19.0 +/- 0.3	
Lateral deviation <sup>2/</sup>			1.5	0.3 max.	
Beta	60 degrees	90 degrees	120 degrees	90 degrees +/- 5 degrees	
Cap BA 15s in accordance with IEC Publication 61 (sheet 7004-11A-8)					
<b>ELECTRICAL AND PHOTOMETRIC CHARACTERISTICS</b>					
Rated values	V	6	12	24	12
	W	5			5
Test voltage	V	6.75	13.5	28.0	
Objective values	W +/- %	5		7	5 at 13.5V
		10			10
	Luminous flux lm +/- %	50			
		20			
Reference luminous flux: 50lm at approx. 13.5V					

<sup>2/</sup> Maximum lateral deviation of filament centre from two reciprocally perpendicular planes both containing reference axis and one containing axis of pins.

<sup>3/</sup> For 24V heavy-duty lamps having a different filament shape, additional specifications are under consideration.

<sup>4/</sup> See paragraph 3.5.3.

<sup>1/</sup> Filament lamps with cap BA 15d may be used for special purposes; they have the same dimensions.

**CATEGORY R10W**

Sheet R10W/1

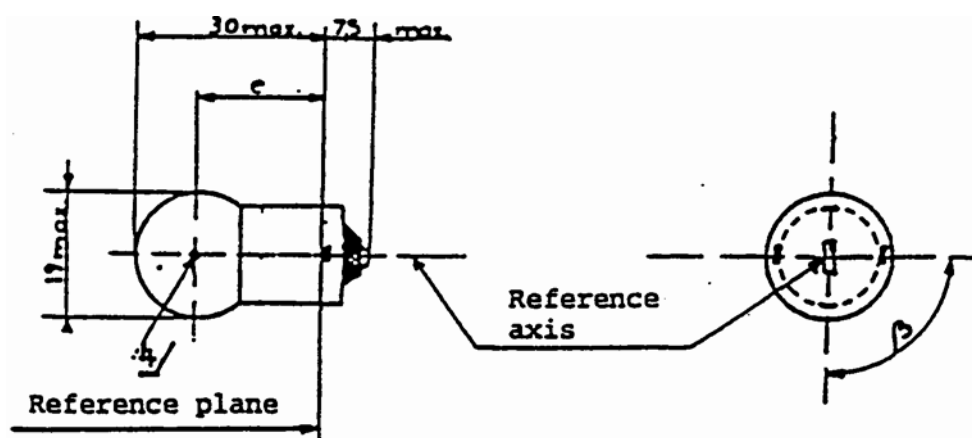

DIMENSIONS in mm	Filament lamps of normal production			Standard filament lamp	
	min.	nom.	Max.		
e	17.5	19.0	20.5	19.0 +/- 0.3	
Lateral deviation <sup>2/</sup>			1.5	0.3 max.	
Beta	60 degrees	90 degrees	120 degrees	90 degrees +/- 5 degrees	
Cap BA 15s in accordance with IEC Publication 61 (sheet 7004-11A-8) <sup>1/</sup>					
<b>ELECTRICAL AND PHOTOMETRIC CHARACTERISTICS</b>					
Rated values	V	6	12	24	12
	W	10			10
Test voltage	V	6.75	13.5	28.0	
Objective values	W +/- %	10		12.5	10 at 13.5V
		10			10
	Luminous flux lm +/- %	125			
		20			
Reference luminous flux: 125lm at approx. 13.5V					

<sup>2/</sup> Maximum lateral deviation of filament centre from two reciprocally perpendicular planes both containing reference axis and one containing axis of pins.

<sup>1/</sup>Filament lamps with cap BA 15d may be used for special purposes; they have the same dimensions.

<sup>3/</sup>For 24V heavy-duty filament lamps having a different filament shape, additional specifications are under consideration.

4/ See paragraph 3.5.3.

**CATEGORY C5W**

Sheet C5W/1

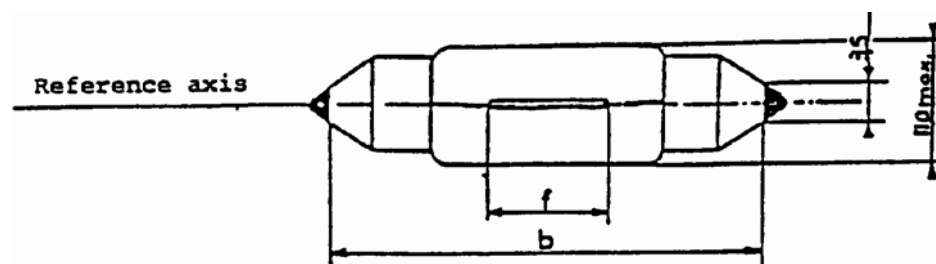

DIMENSIONS in mm	Filament lamps of normal production			Standard filament lamp	
	min.	nom.	max.		
b <sup>1/</sup>	34.0	35.0	36.0	35 +/- 0.5	
f <sup>2/3/</sup>	7.5 <sup>4/</sup>		15 <sup>5/</sup>	9 +/- 1.5	
Cap SV 8.5 in accordance with IEC Publication 61 (sheet 7004-81-4)					
<b>ELECTRICAL AND PHOTOMETRIC CHARACTERISTICS</b>					
Rated values	V	6	12	24	12
	W	5			5
Test voltage	V	6.75	13.5	28.0	
Objective values	W +/- %	5		7	5 at 13.5 V
		10			10
	Luminous flux lm +/- %	45			
Reference luminous flux: 45lm at approx. 13.5V					

<sup>1/</sup> This dimension corresponds to the distance between two apertures of 3.5mm diameter each bearing against one of the caps.

<sup>2/</sup> The filament must be housed in a cylinder 19mm long co-axial with the filament lamp axis and placed symmetrically about the lamp centre. The diameter of this cylinder is for 6V and 12V filament lamps: d + 4mm (for standard filament lamps: d + 2mm) and for 24V filament lamps: d + 5mm, "d" being the nominal diameter of the filament as stated by the manufacturer.

<sup>3/</sup> The deviation of the filament centre from the centre of the lamp's length should not be more than +/- 2.0mm (for standard filament lamps: +/- 0.5mm) measured in the direction of the reference axis.

<sup>4/</sup> 4.5mm for 6V filament lamps.

<sup>5/</sup> 16.5mm for 24V filament lamps.

**CATEGORY C21W**

Sheet C21W/1

**Filament lamps for reversing lamps only**

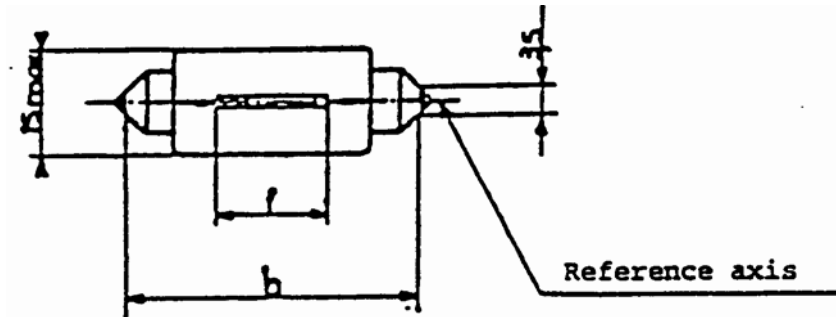

DIMENSIONS in mm	Filament lamps of normal production			Standard filament lamp
	min.	nom.	max.	
b <sup>1/</sup>	40.0	41.0	42.0	41 +/- 0.5
f <sup>2/</sup>	7.5		10.5	8 +/- 1
Cap SV 8.5 in accordance with IEC Publication 61 (sheet 7004-81-4)				
ELECTRICAL AND PHOTOMETRIC CHARACTERISTICS				
Rated values	V		12	12
	W		21	21
Test voltage	V		13.5	
Objective values	W +/- %		25	25 at 13.5 V
			6	6
	Luminous flux lm +/- %	15	15	
Reference luminous flux: 460lm at approx. 13.5V				

<sup>1/</sup> This dimension corresponds to the distance between two apertures of 3.5mm diameter.

<sup>2/</sup> The position of the filament is checked by means of a "box system", sheet C21W/2.

**CATEGORY C21W**

Sheet C21W/2

**Screen Projection Requirements**

This test is used to determine, whether a filament lamp complies with the requirements by checking, whether the filament is correctly positioned relative to the reference axis and to the centre of the lamp's length.

Dimensions in mm

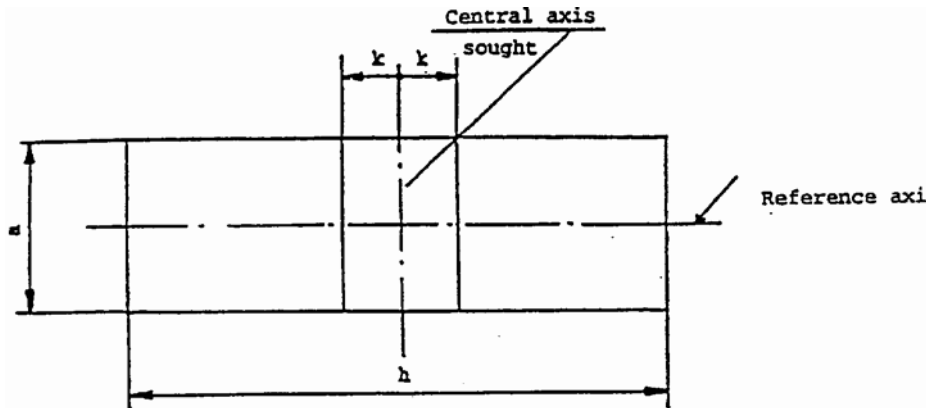

	a	h	k
12V	4.0 + d	14.5	2.0

d = nominal diameter of filament as stated by the manufacturer.

For standard filament lamps: a = 2.0 + d, k = 0.5 Test procedure and requirements

1. The lamp is placed in a holder (socket) capable of being so rotated through 360 degrees about the reference axis and that the front elevation is seen on the screen onto which the image of the filament is projected. The reference plane on the screen should coincide with the centre of the lamp. The central axis sought on the screen should coincide with the centre of the lamp's length.
2. **Front elevation**
  - 2.1 The projection of the filament shall lie entirely within the rectangle when the lamp is rotated through 360 degrees .
  - 2.2 The centre of the filament shall not be offset by more than the distance "k" from the central axis sought.

**CATEGORY T4W**

Sheet T4W/1

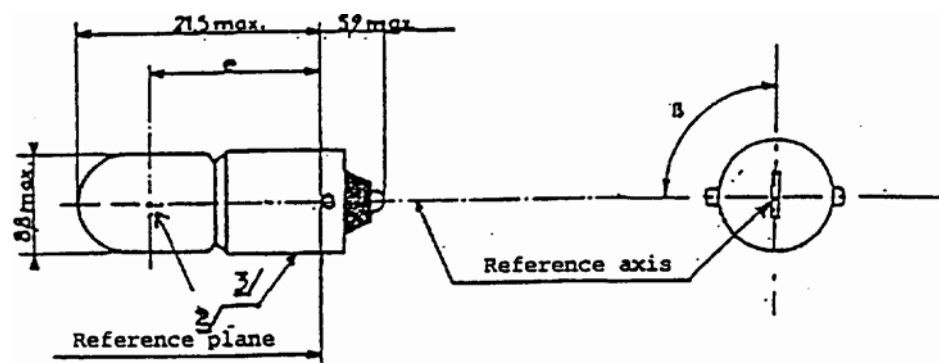

DIMENSIONS in mm	Filament lamps of normal production			Standard filament lamp	
	min.	nom.	max.		
e	13.5	15.0	16.5	15.0 +/- 0.3	
Lateral deviation <sup>1/</sup>			1.5	0.5 max.	
Beta		90 degrees		90 degrees +/- 5 degrees	
Cap BA 9s in accordance with IEC Publication 61 (sheet 7004-14-7) <sup>3/</sup>					
<b>ELECTRICAL AND PHOTOMETRIC CHARACTERISTICS</b>					
Rated values	V	6	12	24	12
	W	4			4
Test voltage	V	6.75	13.5	28.0	
Objective values	W	4		5	4 at 13.5 V
	+/- %	10			10
	Luminous flux lm +/- %	35			
		20			
Reference luminous flux: 35lm at approx. 13.5V					

<sup>1/</sup>Maximum lateral deviation of filament centre from two reciprocally perpendicular planes both containing reference axis and one containing axis of pins.

<sup>2/</sup> See paragraph 3.5.3.

<sup>3/</sup> Over the entire length of the cap there must be no projections or soldering extending beyond the permissible maximum diameter of the cap.

**CATEGORY W3W**

Sheet W3W/1

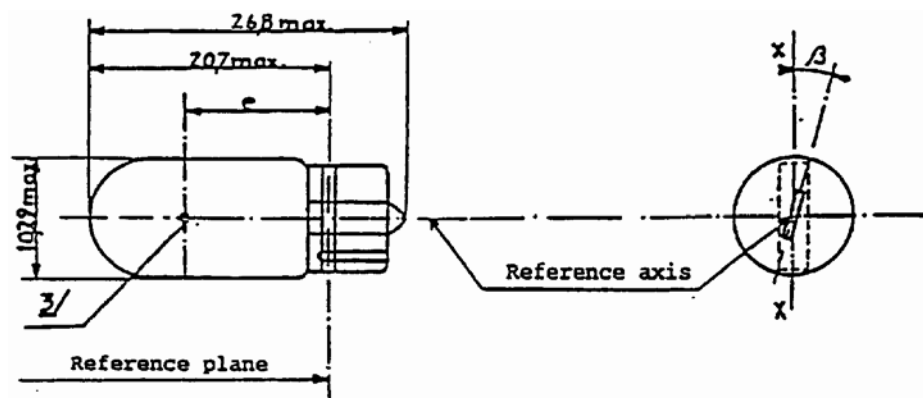

DIMENSIONS in mm	Filament lamps of normal production			Standard filament lamp	
	min.	nom.	max.		
e	11.2	12.7	14.2	12.7 +/- 0.3	
Lateral deviation <sup>2/</sup>			1.5	0.5max.	
beta	- 15 degrees	0 degrees	+ 15 degrees	0 degrees +/- 5 degrees	
Cap W 2.1 x 9.5d in accordance with IEC Publication 61 (sheet 7004-91-3) <sup>1/</sup>					
<b>ELECTRICAL AND PHOTOMETRIC CHARACTERISTICS</b>					
Rated values	V	6	12	24	12
	W	5			5
Test voltage	V	6.75	13.5	28.0	
Objective values	W +/- %	5		7	5 at 13.5V
		10			10
	Luminous flux lm +/- %	50			
		20			
Reference luminous flux: 50lm at approx. 13.5V					

<sup>1/</sup>The type is protected by patents; ISO/IEC conditions apply.

<sup>2/</sup>Maximum lateral deviation of filament centre from two reciprocally perpendicular planes both containing reference axis and one containing axis XX.

<sup>3/</sup> See paragraph 3.5.3.



**CATEGORY W5W**

Sheet W5W/1

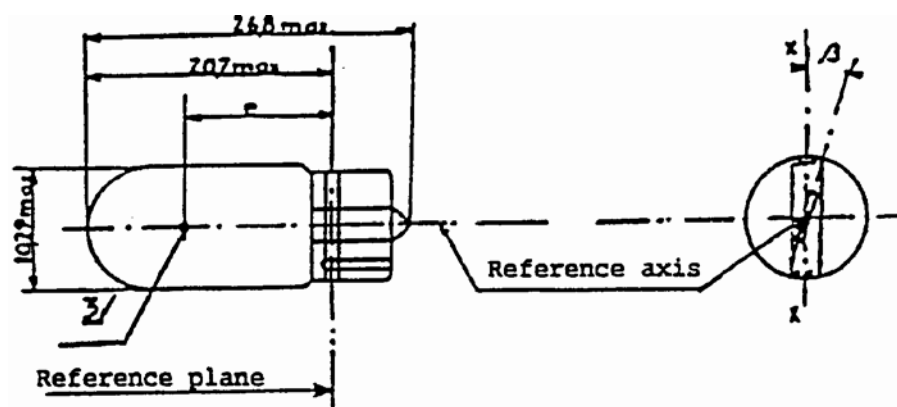

DIMENSIONS in mm	Filament lamps of normal production			Standard filament	
	min.	nom.	max.	Lamp	
e	11.2	12.7	14.2	12.7 +/- 0.3	
Lateral deviation <sup>2/</sup>			1.5	0.5max.	
Beta	- 15 degrees	0 degrees	+ 15 degrees	0 degrees +/- 5 degrees	
Cap W2.1 x 9.5d in accordance with IEC Publication 61 (sheet 7004-91-3) 1/					
<b>ELECTRICAL AND PHOTOMETRIC CHARACTERISTICS</b>					
Rated values	V	6	12	24	12
	W	3			3
Test voltage	V	6.75	13.5	28.0	
Objective values	W +/- %	3		4	3 at 13.5V
		15			15
	Luminous flux lm +/- %	22			
		30			
Reference luminous flux: 22lm at approx. 13.5V					

<sup>1/</sup>The type is protected by patents; ISO/IEC conditions apply.

<sup>2/</sup>Maximum lateral deviation of filament centre from two reciprocally perpendicular planes both containing reference axis and one containing axis XX.

<sup>3/</sup> See paragraph 3.5.3.

**CATEGORIES S1 AND S2: FILAMENT LAMPS FOR MOTOR CYCLES**

Sheet S1/S2/1

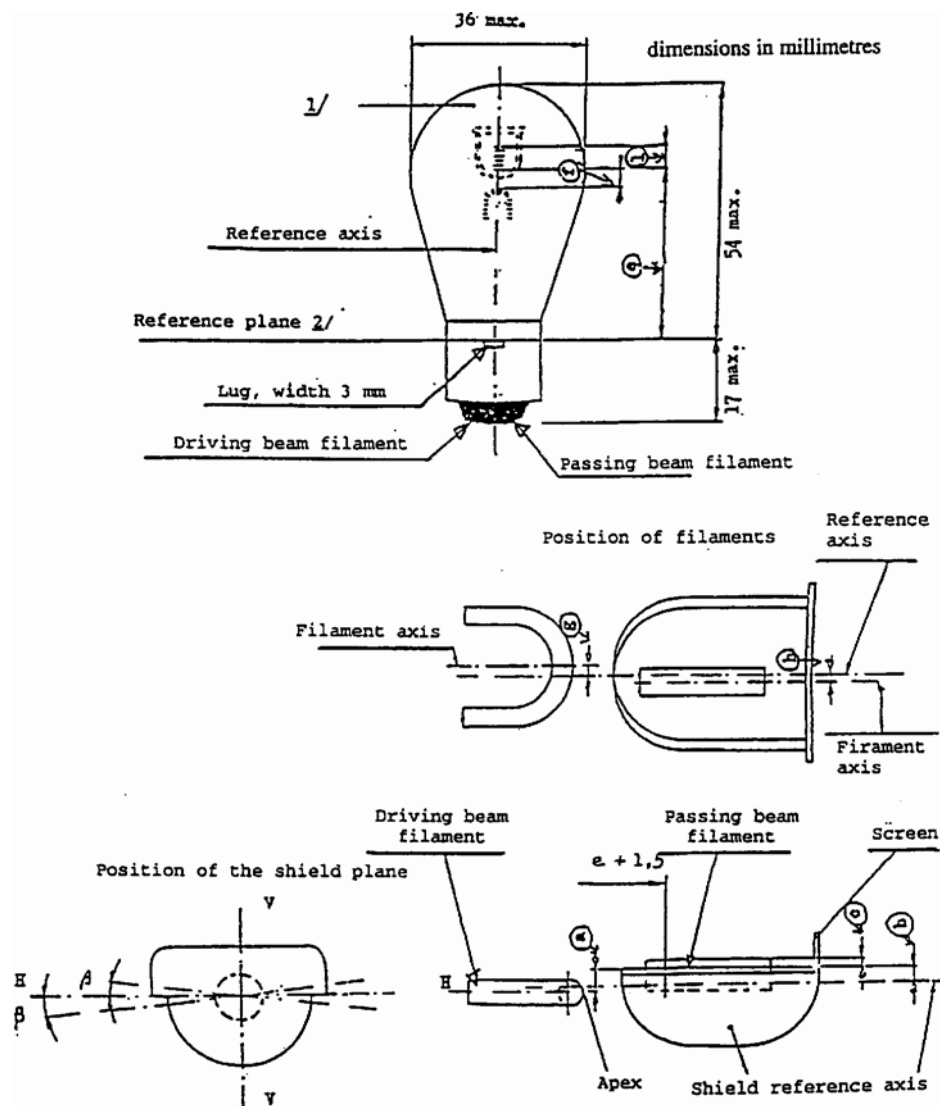

Note Plane V-V contains the reference axis and the centre line of the lugs.  
 Plane H-H (the normal position of the shield) is perpendicular to plane V-V and contains the reference axis.

<sup>1/</sup> Colourless or selective-yellow bulb; the photometric specifications of the table refer to colourless bulbs.

<sup>2/</sup> The reference plane is perpendicular to the reference axis and touches the upper surface of the lug having a width of 4.5mm.

<sup>3/</sup> Dimensions a, b, c and beta refer to a plane parallel to the reference plane and cutting the two edges of the shield at a distance of  $e + 1.5$ mm.

CATEGORY S1 AND S2 FILAMENT LAMPS - DIMENSIONS				
Dimensions mm	Filament lamps of normal production <sup>5/</sup>			Standard filament lamp
	min.	nom.	max.	
e	32.35	32.70	33.05	32.7 +/- 0.15
f	1.4	1.8	2.2	1.8 +/- 0.2
l	4	5.5	7	5.5 +/- 0.5
c	0.2	0.5	0.8	0.5 +/- 0.15
<sup>3/</sup> b	-0.15	0.2	0.55	0.2 +/- 0.15
<sup>3/</sup> a	0.25	0.6	0.95	0.6 +/- 0.15
<sup>3/</sup> h	-0.5	0	0.5	0 +/- 0.2
g	-0.5	0	0.5	0 +/- 0.2
Beta <sup>3</sup> <sub>4/</sub>	-2 degrees 30'	0	2 degrees 30'	0 degrees +/- 1 degrees
Cap BA 20d in accordance with Publication IEC 61 (sheet 7004-12-7)				

<sup>4/</sup> Admissible angular deviation of the shield plane position from the normal position

ELECTRICAL AND PHOTOMETRIC CHARACTERISTICS						
CATEGORY S1 FILAMENT LAMP						
Rated values	V	Filament lamps of <sup>5/</sup> normal production				Standard filament lamp
		W	25	25	25	
Test voltage	V	6.75		13.5		-
Objective values	W	25	25	25	25	25 25 at 6.75V
	+/- %	5		5		5
	Lumens	435	315	435	315	-
	+/- %	20		20		-
Reference luminous flux: 398lm and 284lm respectively at approx. 6V						
CATEGORY S2 FILAMENT LAMPS						
Rated values	V	Filament lamps of <sup>5/</sup> normal production				Standard filament lamp
		W	35	35	35	
Test voltage	V	6.3		13.5		-

ELECTRICAL AND PHOTOMETRIC CHARACTERISTICS						
Objective values	W	35	35	35	35	35 35 at 13.5V
	+/- %	5		5		5
	Lumens	650	465	650	465	-
	+/- %	20		20		-
Reference luminous flux: 568lm and 426lm respectively at approx. 12V						

<sup>1/</sup> Colourless or selective-yellow bulb; the photometric specifications of the table refer to colourless bulbs.

<sup>2/</sup> the reference plane is perpendicular to the reference axis and touches the upper surface of the lug having a width of 4.5 mm.

<sup>3/</sup> Dimensions a, b, c and  $\beta$  refer to a plane parallel to the reference plane and cutting the two edges of the shield at a distance of  $3 + 1.5$  mm.

<sup>4/</sup> Admissible angular deviation of the shield plane position from the normal position.

<sup>5/</sup> Type approval requirements. Requirements for the conformity of production are under consideration.

**CATEGORY S3: FILAMENT LAMP FOR MOPEDS**

Dimensions in mm

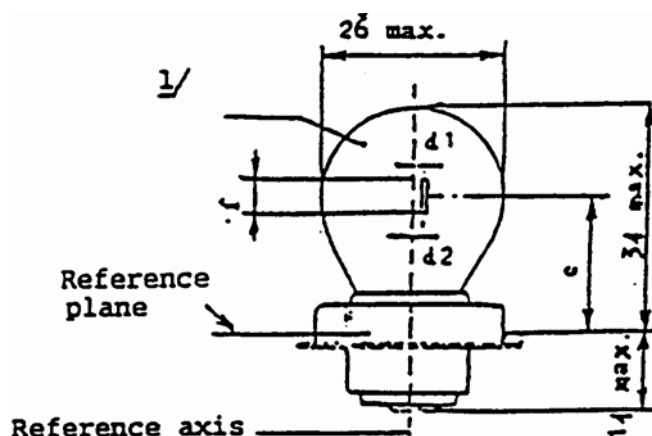

Dimensions in mm	Lamps of normal production			Standard filament lamp
	min.	Nom.	max.	
e <sup>2/</sup>	19.0	19.5	20.0	19.5 +/- 0.25
f (6 V)			3.0	2.5 +/- 0.5
f (12 V)			4.0	
d1, d2 <sup>3/</sup>	- 0.5	0	+ 0.5	+/- 0.3
Cap S26s in accordance with IEC Publication 61 (sheet 7004-36-1)				
<b>ELECTRICAL AND PHOTOMETRIC CHARACTERISTICS</b>				
Rated values	V	6	12	6
	W	15		15
Test voltage	V	6.75	13.5	
Objective values	W +/- %	15		15 at 6.75V
		6		6
	Luminous flux lm +/- %	240		
		15		
Reference luminous flux: 240lm at approximately 6.75V				

<sup>1/</sup> Colourless or selective-yellow bulb; the photometric specifications of the table refer to colourless bulbs.

<sup>2/</sup> Distance related to the luminous centre of gravity.

<sup>3/</sup> Lateral deviation of filament axis with respect to the reference axis. It is sufficient to check this deviation in two reciprocally perpendicular planes.

**CATEGORY S4 : FILAMENT LAMP FOR MOPED HEADLAMP**

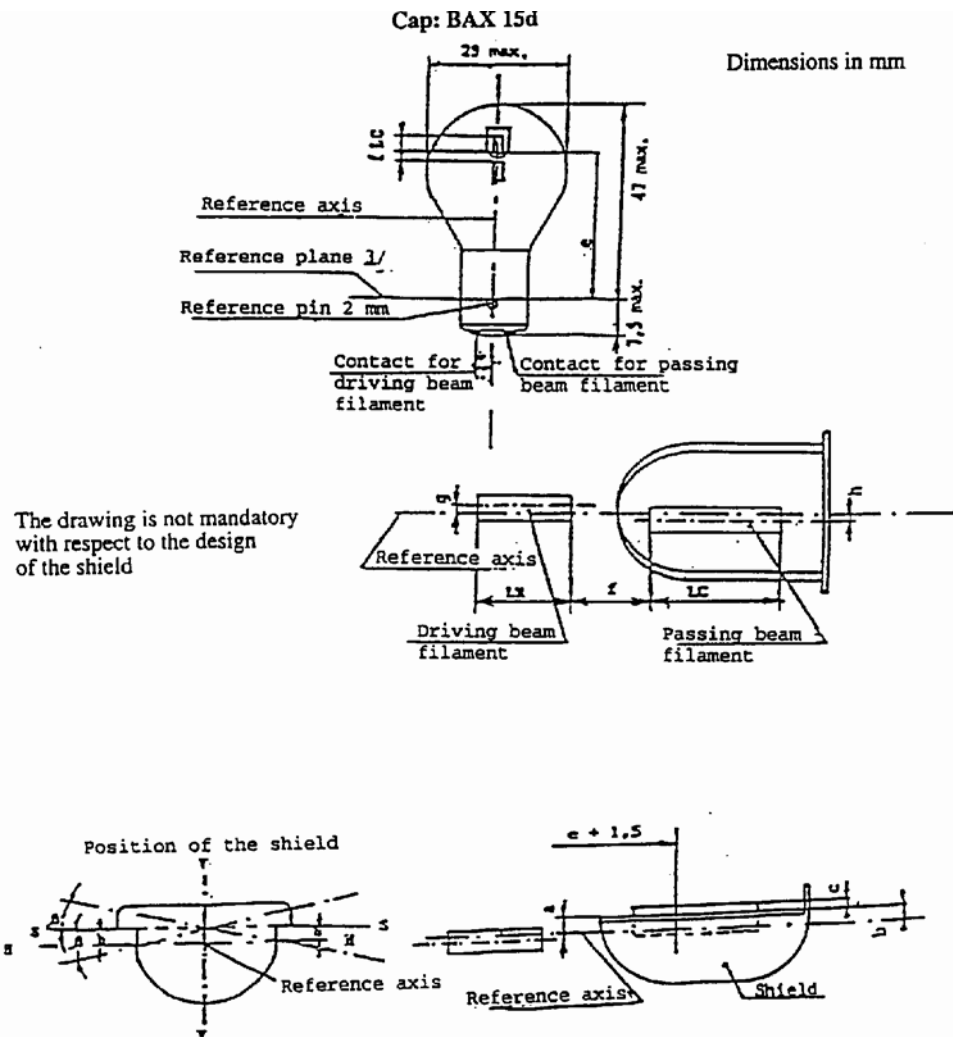

Plane VV contains the reference axis and the centre line of the reference pin. Plane HH contains the reference axis and is perpendicular to plane VV. Objective position of plane SS through the shield edges parallel to plane HH.

**CATEGORY S4 : FILAMENT LAMP FOR MOPED HEADLAMP**

Sheet S4/2

**Cap: BAX 15d**

	Filament lamps of normal production				Standard filament Lamp	
Dimension (mm)	min.	nom.	max.			
e	33.25	33.6	33.95	33.6 +/- 0.15		
f	1.45	1.8	2.15	1.8 +/- 0.2		
LC, LR	2.5	3.5	4.5	3.5 +/- 0.5		
c <sup>2/</sup>	0.05	0.4	0.75	0.4 +/- 0.15		
b <sup>2/</sup>	-0.15	0.2	0.55	0.2 +/- 0.15		
a <sup>2/</sup>	0.25	0.6	0.95	0.6 +/- 0.15		
h	-0.5	0	0.5	0 +/- 0.2		
g	-0.5	0	0.5	0 +/- 0.2		
beta <sup>2/ 5/</sup>	-2 degrees 30'	0	2 degrees 30'	0 +/- 1 degrees		
Cap <sup>1/</sup>	BAX 15d					
<b>ELECTRICAL AND PHOTOMETRIC CHARACTERISTICS</b>						
Rated voltage V	6		12		6	
Rated wattage <sup>6/</sup> W	15	15	15	15	15	15
Test voltage V	6.75		13.5			
Objective W wattage <sup>6/</sup>	15	15	15	15	15	15
					[at 6.75 V]	
Tolerance +/- %	6		6		6	
Objective lum.	180	125 190	180	125 190		
flux. lm <sup>4/ 6/</sup>	min.	min. max.	min.	min. max.		
Reference luminous flux: 240lm (driving beam), 160lm (passing beam)						
at approx. 6V <sup>4/</sup>						

---

**CATEGORY S4**

Sheet S4/3

Notes

- <sup>1/</sup> Cap in accordance with IEC Publication 61 in preparation.
- <sup>2/</sup> Dimensions a, b, c and  $\beta$  refer to a plane parallel to the reference plane and cutting the two edges of the shield at a distance of  $e + 1.5\text{mm}$ .
- <sup>3/</sup> The reference plane is perpendicular to the reference axis and touches the upper surface of the pin having a length of 2mm.
- <sup>4/</sup> Colourless or selective yellow bulb, the photometric specifications of the table refer to the colourless bulb.
- <sup>5/</sup> Admissible deviation of the plane through the shield edges from the objective position.
- <sup>6/</sup> Values in the left-hand column refer to the driving beam filament, values in the right-hand column refer to the passing beam filament.



**CATEGORY HS1**

Sheet HS1/1

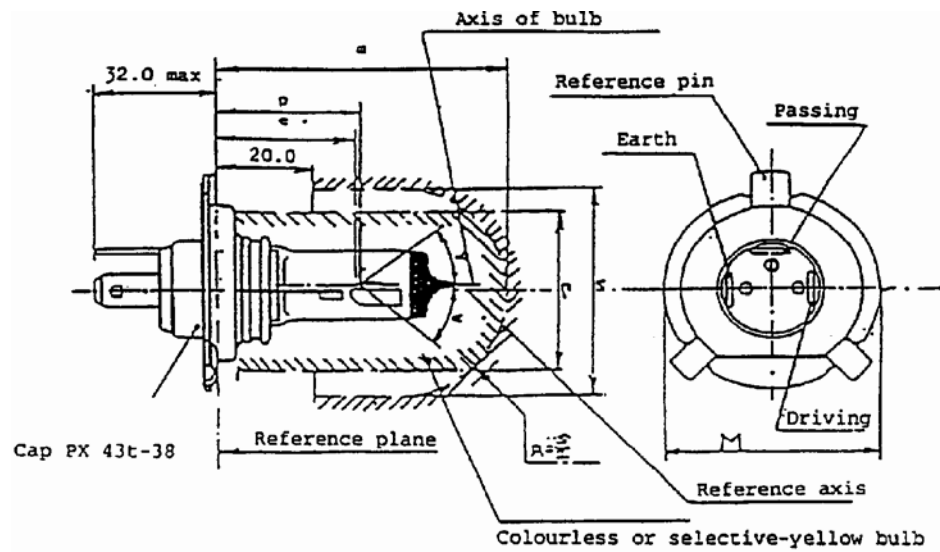

(Dimensions in mm)

The drawings are not mandatory; their sole purpose is to show which dimensions must be verified.

Reference	Dimension		Tolerance	
	6V	12V	6V	12V
e	28.5		+0.45 -0.25	
p	28.95		-	
m <sup>1/</sup>	max. 60.0		-	
n <sup>1/</sup>	max. 34.5		-	
s <sup>2/</sup>	45.0		-	
alpha <sup>3/</sup>	max. 40 degrees		-	

**CATEGORY HS1**

Sheet HS1/2

**Characteristics**

Rated values	V	Filament lamps of normal production				Standard filament lamps	
		6 <sup>4/</sup>		12 <sup>4/</sup>		12 <sup>4/</sup>	
	W	35	35	35	35	35	35
Test voltage	V	6.3		13.2			
Objective values	W +/- %	35 5	35 5	35 5	35 5	35 at 13.2V 5	35 at 13.2V 5
	Luminous flux lm	700	440	825	525		
	+/- %	15					
Measuring luminous flux according to para. 3.8 of this Regulation	lm				450		
Reference luminous flux at approximately 12Vlm						700	450
Cap PX43t-38 in accordance with IEC Publication 61 (sheet 7004-34-2)							

**CATEGORY HS1**

Sheet HS1/3

**Table of the dimensions referred to in the diagrams on sheets 4 and 5 (in mm)**

Reference		Dimension		Tolerances		
				Filament lamps of normal production		Standard filament lamp
6V	12V	6V	12V	6V	12V	12V
a/26 <sup>*/</sup>		0.8		+/- 0.35		+/- 0.2
a/25 <sup>*/</sup>		0.8		+/- 0.55		+/- 0.2
b <sub>1</sub> /29.5 <sup>*/</sup>		0		+/- 0.35		+/- 0.2
b <sub>1</sub> /33 <sup>*/</sup>		b <sub>1</sub> /29.5mv		+/- 0.35		+/- 0.15
b <sub>2</sub> /29.5 <sup>*/</sup>		0		+/- 0.35		+/- 0.2
b <sub>2</sub> /33 <sup>*/</sup>		b <sub>2</sub> /29.5mv		+/- 0.35		+/- 0.15
c/29.5 <sup>*/</sup>		0.6		+/- 0.35		+/- 0.2
c/31 <sup>*/</sup>		c/29.5mv		+/- 0.30		+/- 0.15
d		min. 0.1 max. 1.5		-		-
e <sup>7/</sup>		28.5		+ 0.45 - 0.25		+ 0.2 - 0.0
f <sup>5/ 6/ 8/</sup>		1.7		+ 0.50 - 0.30		+ 0.3 - 0.1
g/25 <sup>*/</sup>		0		+/- 0.5		+/- 0.3
g/25 <sup>*/</sup>		0		+/- 0.7		+/- 0.3
h/29.5 <sup>*/</sup>		0		+/- 0.5		+/- 0.3
h/31 <sup>*/</sup>		h/29.5		+/- 0.30		+/- 0.2
IR 5/ 8/		3.5	4.0	+/- 0.8		+/- 0.4
lc 5/ 6/		3.3	4.5	+/- 0.8		+/- 0.35
p/33 <sup>*/</sup>		Depends on the shape of the shield		-		-
q/33 <sup>*/</sup>		$\frac{p+q}{2}$		+/- 0.6		+/- 0.3

<sup>\*/</sup> Dimension to be measured at the distance from the reference plane indicated in mm after the stroke.

**CATEGORY HS1**

Sheet HS1/4

Position of filaments<sup>\*/</sup>

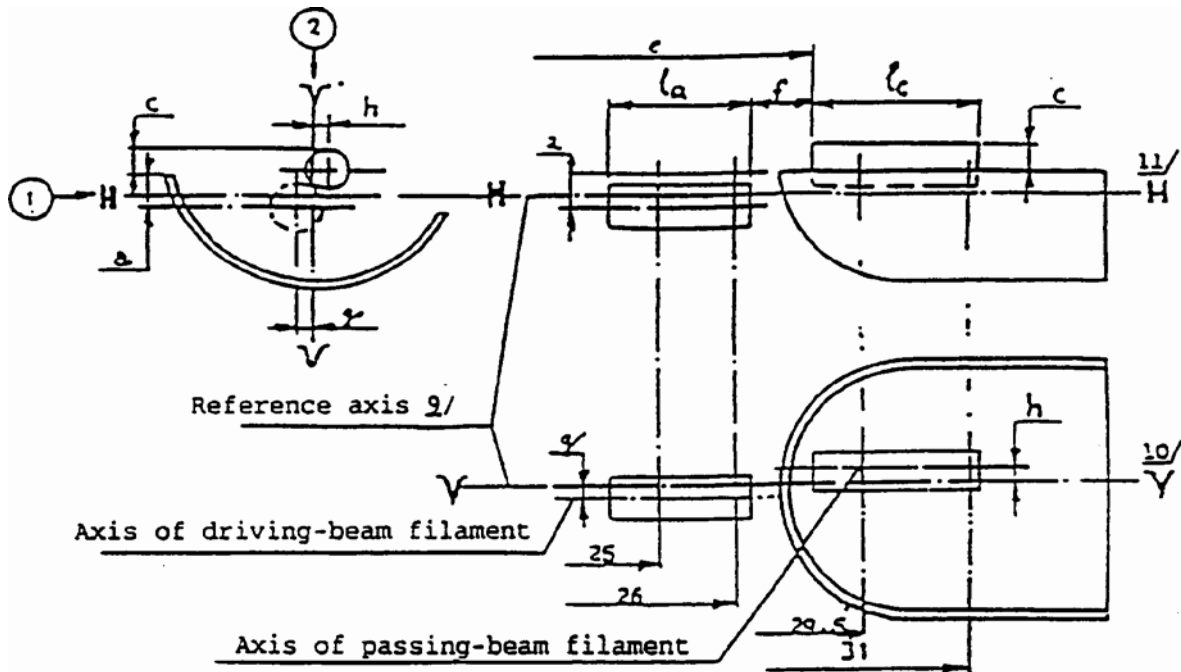

Dimensions in millimetres

<sup>\*/</sup> The drawing is not mandatory with respect to the design of the shield.

**CATEGORY HS1**

Sheet HS1/5

Position of shield <sup>\*/</sup>

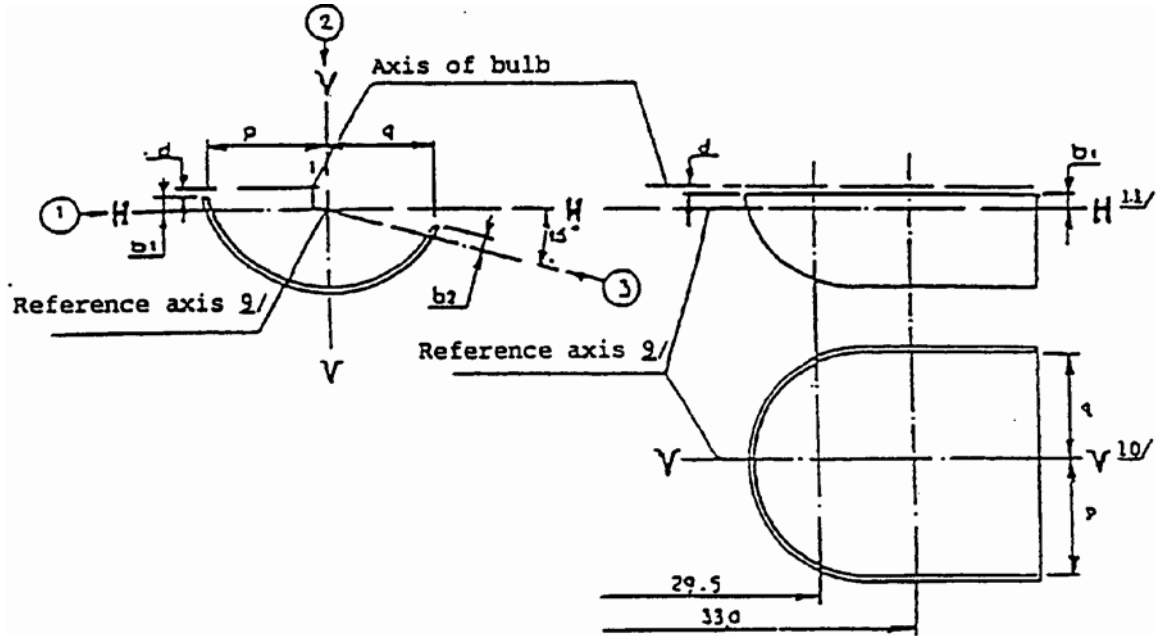

<sup>\*/</sup> The drawing is not mandatory with respect to the design of the shield.

---

**CATEGORY HS1**

Sheet HS1/6

**Additional explanations to Sheets HS1/4 and HS1/5**

The dimensions below are measured in three directions:

- (1) for dimension a, b<sub>1</sub>, c, d, e, f, l<sub>r</sub> and l<sub>c</sub>;
- (2) for dimensions g, h, p and q;
- (3) for dimension b<sub>2</sub>.

Dimensions p and q are measured in a plane parallel to 33mm away from the reference plane. Dimensions b<sub>1</sub>, b<sub>2</sub>, are measured in planes parallel to and 29.5 and 33mm away from the reference plane. Dimensions a and g are measured in planes parallel to and 25 and 26mm away from the reference plane. Dimensions c and h measured in planes parallel to and 29.5 and 31mm away from the reference plane.

---

**CATEGORY HS1**

Sheet HS1/7

- 1/ Where a yellow outer bulb is used, "m" and "n" denote the maximum dimensions of this bulb; where there is no outer bulb, "m" denotes the maximum length of the lamp.
- 2/ It must be possible to insert the filament lamp into a cylinder of diameter "s" concentric with the reference axis and limited at one end by a plane parallel to and 20mm distant from the reference plane and at the other end by a hemisphere of radius s/2.
- 3/ The obscuration must extend at least as far as the cylindrical part of the bulb. It must also overlap the internal shield when the latter is viewed in a direction perpendicular to the reference axis. The effect sought by obscuration may also be achieved by other means.
- 4/ The values indicated in the left-hand column relate to the driving beam. Those indicated in the right-hand column relate to the passing beam.
- 5/ The end turns of the filaments are defined as being the first luminous turn and the last luminous turn that are at substantially the correct helix angle. For coiled-coil filaments, the turns are defined by the envelope of the primary coil.
- 6/ For the passing-beam filament the points to be measured are the intersections, seen in direction (1), of the lateral edge of the shield with the outside of the end turns defined under footnote 5.
- 7/ "e" denotes the distance from the reference plane to the beginning of the passing-beam filament as defined above.
- 8/ For the driving-beam filament the points to be measured are the intersections, seen in direction (1), of a plane, parallel to plane HH and situated at a distance of 0.8mm below it, with the end turns defined under footnote 5.
- 9/ The reference axis is the line perpendicular to the reference plane and passing through the centre of the circle of diameter "M" (see Sheet 1).
- 10/ Plane VV is the plane perpendicular to the reference plane and passing through the reference axis and through the intersection of the circle of diameter "M" with the axis of the reference pin.
- 11/ Plane HH is the plane perpendicular to both the reference plane and plane VV and passing through the reference axis.

**CATEGORY HS2: HALOGEN MOPED FILAMENT LAMP**

Sheet HS2/1

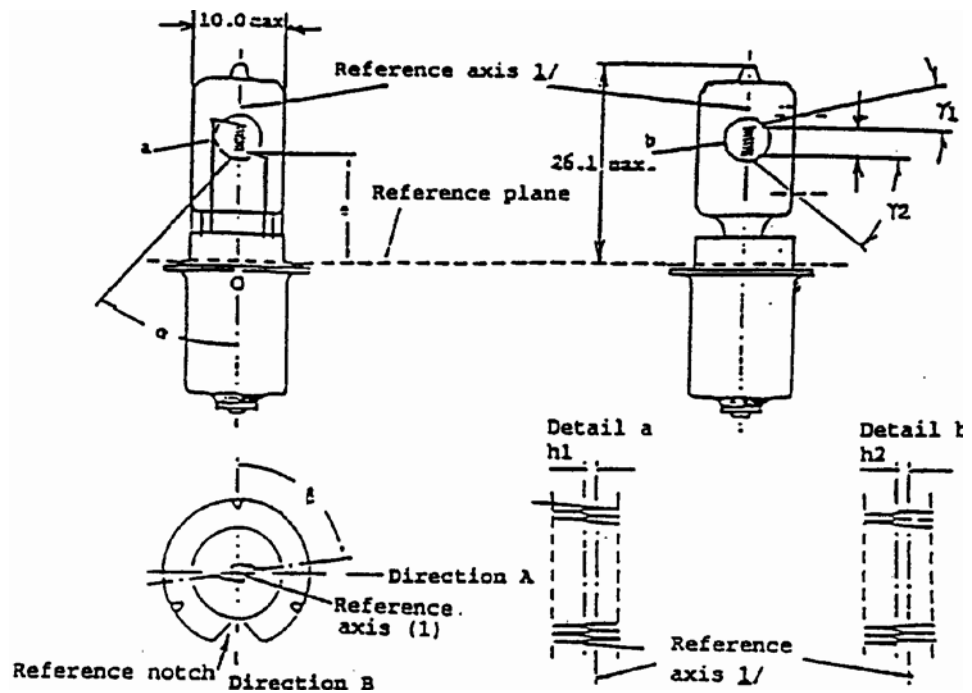

Dimensions in mm	Filament lamps of normal production			Standard filament lamp
	Minimum	Nominal	Maximum	
e		11.0 3/		11.0 +/- 0.15
f (6V) <sup>6/</sup>	1.5	2.5	3.5	2.5 +/- 0.15
f (12V) <sup>6/</sup>	2.0	3.0	4.0	
h <sub>1</sub> , h <sub>2</sub>		3/		0 +/- 0.15
alpha <sup>4/</sup>			40	
beta <sup>5/</sup>	- 15 degrees	90 degrees	+ 15 degrees	90 degrees +/- 5 degrees
gamma <sub>1</sub> <sup>7/</sup>	15 degrees			15 degrees min.
gamma <sub>2</sub> <sup>7/</sup>	40 degrees			40 degrees min.
Cap PX13.5a in accordance with IEC Publication 61 (sheet 7004-35-2)				
<b>ELECTRICAL AND PHOTOMETRIC CHARACTERISTICS</b>				
Rated values	V <sup>6/</sup>	6	12	6
	W	15	15	15
Test voltage	V	6.75	13.5	



Dimensions in mm		Filament lamps of normal production			Standard filament
		Minimum	Nominal	Maximum	lamp
Objective values	W +/- %	15 6		15 6	15.0 at 6.75V 6
	Luminous flux lm +/- %	320 15		320 15	
Reference luminous flux: 320lm at approximately 6.75V					

---

**CATEGORY HS2: HALOGEN MOPED FILAMENT LAMP**

Sheet HS2/2

- 1/ The reference axis is perpendicular to the reference plane and passes through the intersection of this plane with the axis of the cap ring.
- 2/ To be reserved.
- 3/ To be checked by means of the 'box system' sheet HS2/3.
- 4/ All parts which may obscure the light or may influence the light beam shall lie within angle alpha.
- 5/ Angle beta denotes the position of the plane through the inner leads with reference to the reference notch.
- 6/ In order to avoid rapid lamp failure the supply voltage shall not exceed 8.5V for 6V lamps and 15V for 12V filament lamps.
- 7/ In the area between the outer legs of the angles  $\gamma_1$  and  $\gamma_2$  the bulb shall have no optically distorting areas and the curvature of the bulb must have a radius not less than 50% of the actual bulb diameter.

**CATEGORY HS2: HALOGEN MODERN FILAMENT LAMP**

Sheet HS2/3

**Screen Projection Requirements**

This text is used to determine whether a filament lamp complies with the requirements, by checking whether the filament is correctly positioned in relation to the reference axis and the reference plane.

All dimensions in mm

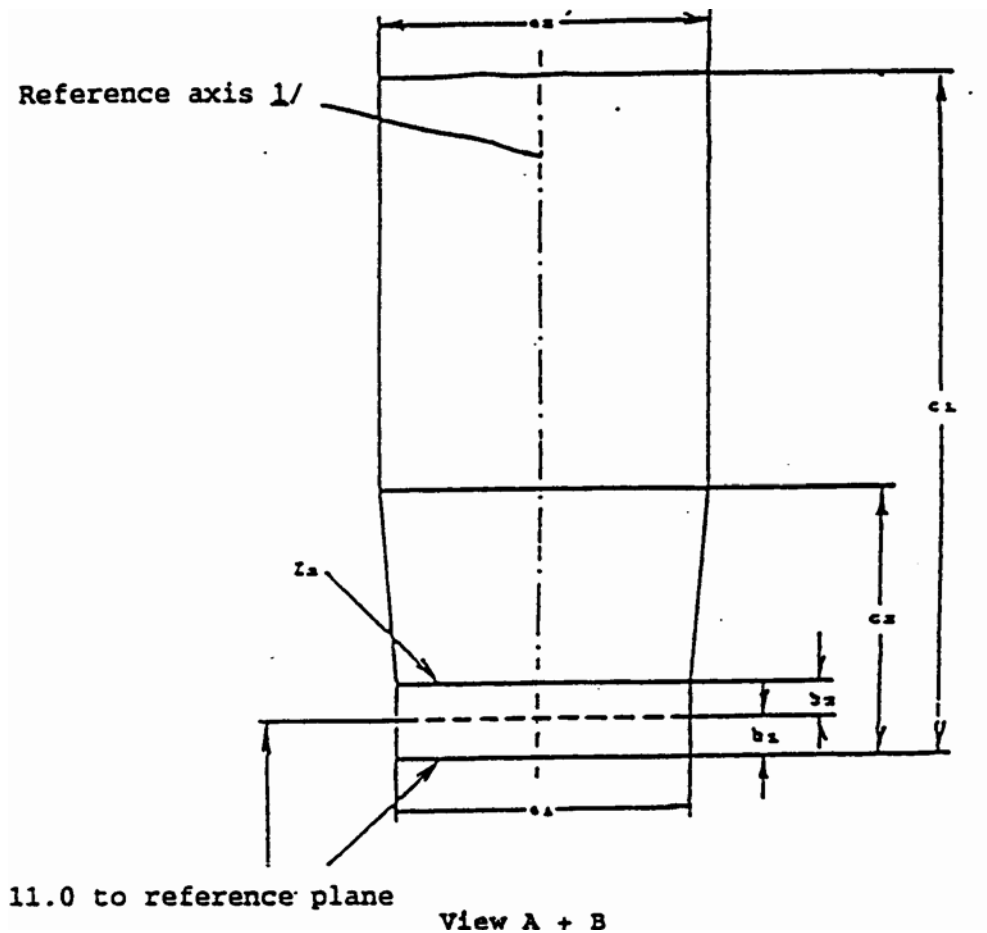

Reference	$a_1$	$a_2$	$b_1$	$b_2$	$c_1$ (6V)	$c_1$ (12V)	$c_2$
Dimension	$d + 1.0$	$d + 1.4$	0.25	0.25	4.0	4.5	1.75

$d$  = actual filament diameter

The filament must lie entirely within the limits shown.

The beginning of the filament must lie between lines  $Z_1$  and  $Z_2$ .

**CATEGORY PY21W**

Sheet PY21W/1

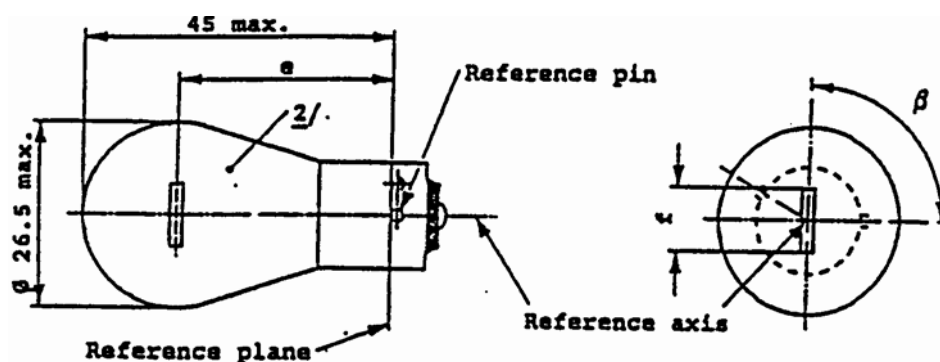

Dimensions in mm	Filament lamps of normal production			Standard filament lamp <sup>5/</sup>	
	min.	nom.	max.		
e		31.8 <sup>3/</sup>		31.8 +/- 0.3	
f <sup>4/</sup>			7.0	7.0 + 0 - 2	
Lateral deviation <sup>1/</sup>		3/		0.3 max.	
beta	75 degrees	90 degrees	105 degrees	90 degrees +/- 5 degrees	
Cap BAU15s: in accordance with IEC Publ. 61 (sheet 7004-19-1)					
<b>ELECTRICAL AND PHOTOMETRIC CHARACTERISTICS</b>					
Rated values	V	12	24	12	
	W	21		21	
Test voltage	V	13.5	28.0		
Objective values	W	W	25	28	25 at 13.5V
		+/- %	6		6
	Luminous flux	lm	280		
		+/- %	20		
Reference luminous flux:	Amber bulb: 280lm Clear bulb: 460lm			at approx. 13.5V	

<sup>5/</sup> The bulb of standard filament lamps shall be amber or clear. For amber standard filament lamps, changes of the bulb temperature shall not affect the luminous flux which might impair photometric measurements of signalling devices. Moreover the colour shall be in the lower part of the tolerance area.

<sup>4/</sup> For 24V heavy-duty lamps having a different filament shape, additional specifications are under consideration.

<sup>1/</sup> Maximum lateral deviation of filament centre from two mutually perpendicular planes both containing the reference axis and one containing the axis of the reference pin.

<sup>2/</sup> The bulb of production lamps shall be amber. (See also note 5/).

<sup>3/</sup> To be checked by means of a box system, sheet PY21W/2.

**CATEGORY PY21W**

Sheet PY21W/2

**Screen projection requirements**

This test is used to determine, by checking whether the filament is correctly positioned relative to the reference axis and the reference plane and has an axis perpendicular, within +/- 15 degrees, to the plane through the centre line of the reference pin and the reference axis, whether a filament lamp complies with the requirements.

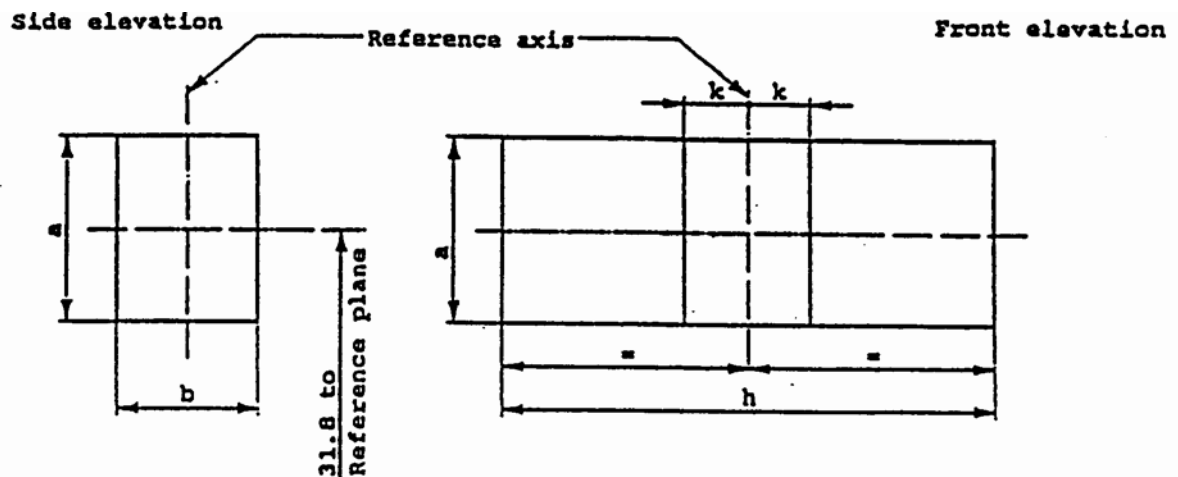

Reference	a	b	h	k
Dimension	3.5	3.0	9.0	1.0

Test procedures and requirements.

1. The filament lamp is placed in a holder capable of being rotated about its axis and having either a calibrated scale or fixed stops corresponding to the angular displacement tolerance limits. The holder is then so rotated that an end view of the filament is seen on the screen on to which the image of the filament is projected. The end view of the filament shall be obtained within the angular displacements tolerance limits.
2. **Side elevation**  
  
The filament lamp placed with the cap down, the reference axis vertical and the filament seen end-on, the projection of the filament shall lie entirely within a rectangle of height "a" and width "b", having its centre at the theoretical position of the centre of the filament.
3. **Front elevation**  
  
The filament lamp placed with the cap down and the reference axis vertical, the filament lamp being viewed in a direction at right angles to the filament axis:
  - 3.1 The projection of the filament shall lie entirely within a rectangle of height "a" and width "h", having its centre at the theoretical position of the centre of the filament.
  - 3.2 The centre of the filament shall not be offset by more than distance "k" from the reference axis.

**CATEGORY H6W**

Sheet H6W

The drawings are intended only to illustrate the essential dimensions of the filament lamp

Dimensions in mm

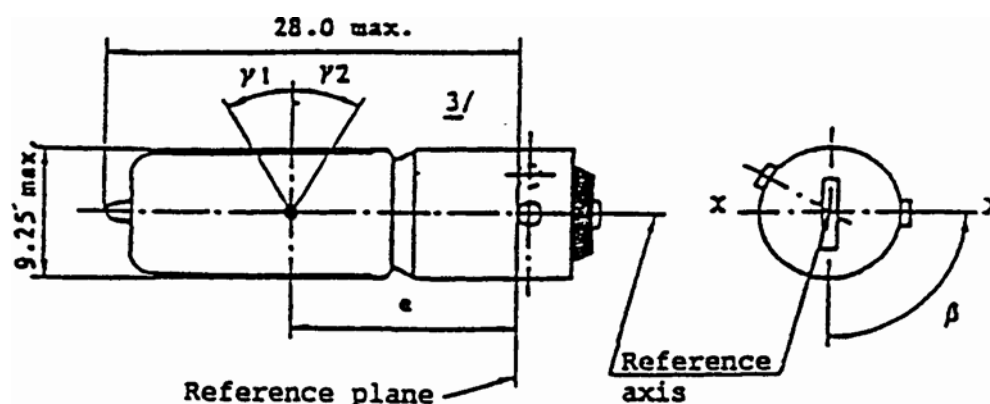

Dimensions in mm	Filament lamps of normal production			Standard filament lamp
	min.	nom.	max.	
e	14.25	15.0	15.75	15.0 +/- 0.25
Lateral deviation <sup>1/</sup>			0.75	0.4 max.
beta	82.5	90	97.5	90 degrees +/- 5 degrees
gamma <sub>1</sub> <sup>2/</sup>	30 degrees			30 degrees
gamma <sub>2</sub> <sup>2/</sup>	30 degrees			30 degrees
Cap BAX9s in accordance with IEC Publication 61 (sheet 7004-8-1)				
<b>ELECTRICAL AND PHOTOMETRIC CHARACTERISTICS</b>				
Rated values	V	12		12
	W	6		6
Test voltage	V	13.5		
Objective values	W	7		7 at 13.5V
	+/- %	5		5
	Luminous flux lm	125		
	+/- %	12		
Reference luminous flux: 125lm at approx. 13.5V				

<sup>1/</sup> Maximum lateral deviation of filament centre from two reciprocally perpendicular planes both containing the reference axis and one containing axis X-X.

<sup>2/</sup> In the area between the outer legs of the angles  $\gamma_1$  and  $\gamma_2$  the bulb shall have no optically distorting areas and the curvature of the bulb shall have a radius not less than 50% of the actual bulb diameter.

<sup>3/</sup> Over the entire length of the cap there shall be no projection or soldering exceeding the permissible maximum diameter of the cap.

**CATEGORIES HB3 AND HB3A**

Sheet HB3/1

The drawings are only to illustrate the essential dimensions of the filament lamp

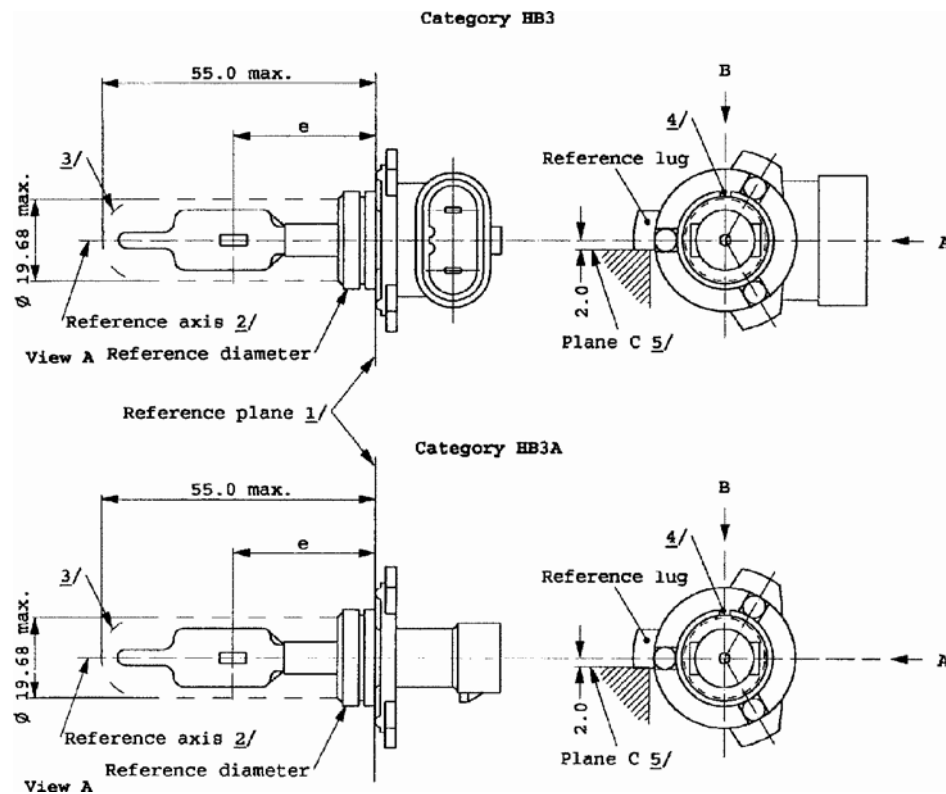

- 1/ The reference plane is the plane defined by the meeting points of the cap-holder fit.
- 2/ The reference axis is perpendicular to the reference plane and concentric with the reference diameter of the cap.
- 3/ Glass bulb and supports shall not exceed the envelope and shall not interfere with insertion past the lamp key. The envelope is concentric to the reference axis.
- 4/ The keyway is mandatory.
- 5/ The filament lamp shall be rotated in the measuring holder until the reference lug contacts plane C of the holder.

**CATEGORIES HB3 AND HB3A**

Sheet HB3/2

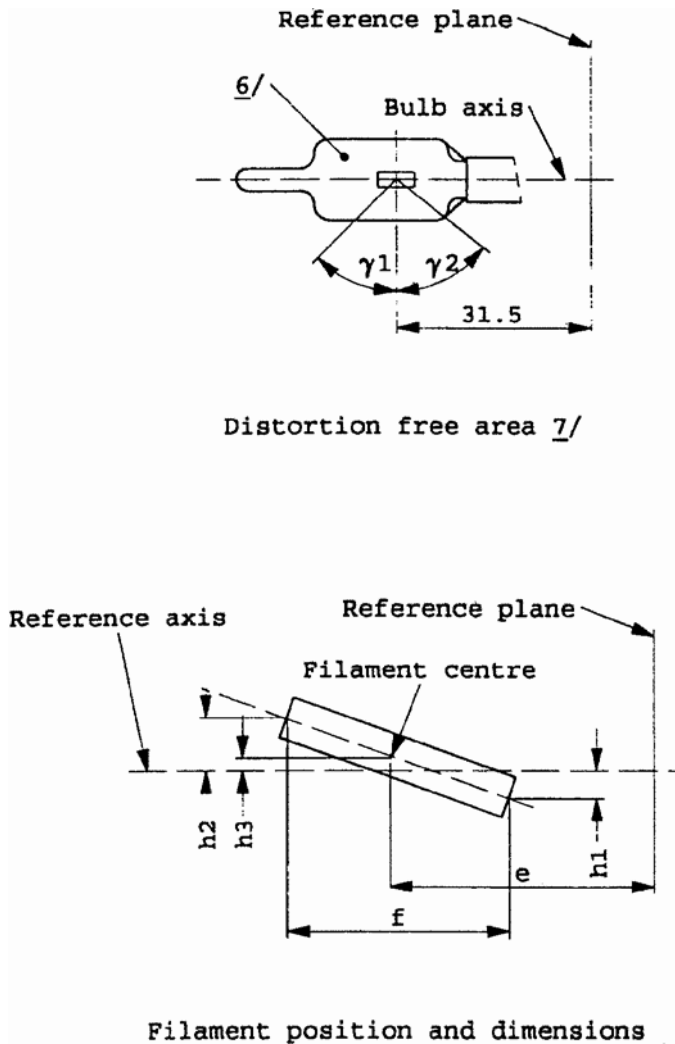

<sup>6/</sup> The bulb shall be colourless or yellow.

<sup>7/</sup> Glass bulb periphery shall be optically distortion-free axially within the angles  $\gamma_1$  and  $\gamma_2$ . This requirement applies to the whole bulb circumference within the angles  $\gamma_1$  and  $\gamma_2$ .



**CATEGORIES HB3 AND HB3A**

Sheet HB3/3

Dimensions in mm <sup>12/</sup>		Tolerances	
		Filament lamps of normal production	Standard filament lamp
e <sup>9/</sup> 11	31.5	10	+/- 0.16
f <sup>9/</sup> 11	5.1	10	+/- 0.16
h <sub>1</sub> , h <sub>2</sub>	0	10	+/- 0.15 <sup>8/</sup>
h <sub>3</sub>	0	10	+/- 0.08 <sup>8/</sup>
gamma <sub>1</sub>	45 degrees min.	-	-
gamma <sub>2</sub>	52 degrees min.	-	-
Cap P 20d in accordance with IEC 61 (sheet 7004-31-2) <sup>13/</sup>			
<b>ELECTRICAL AND PHOTOMETRIC CHARACTERISTICS</b>			
Rated values	V	12	12
	W	60	60
Test voltage	V	13.2	13.2
Objective values	W	73 max.	73 max.
	Luminous flux 1m +/-	1,860	
	%	12	
Reference luminous flux for headlamp testing: 1,300 1m at approx. 12V			

<sup>8/</sup> The eccentricity is measured only in viewing directions <sup>\*/</sup> A and B as shown in the figure on sheet HB3/1. The points to be measured are those where the projection of the outside of the end turns nearest to or furthest from the reference plane crosses the filament axis.

<sup>9/</sup> The viewing direction is direction <sup>\*/</sup> B as shown in the figure on sheet HB3/1.

<sup>10/</sup> To be checked by means of a "box-system". Sheet HB3/4. <sup>\*/</sup>

<sup>11/</sup> The ends of the filament are defined as the points where, when the viewing direction <sup>\*/</sup> as defined in note above, the projection of the outside of the end turns crosses the filament axis.

<sup>12/</sup> Dimensions shall be checked with O-ring removed.

<sup>13/</sup> Filament lamp HB3 shall be equipped with the right-angle cap and filament lamp HB3A with the straight cap.

<sup>\*/</sup>Manufacturers may choose another set of perpendicular viewing directions. The viewing directions specified by the manufacturer are to be used by the testing laboratory when checking filament dimensions and position.

**CATEGORIES HB3 AND HB3A**

Sheet HB3/4

**Screen projection requirements**

This test is used to determine, by checking whether the filament is correctly positioned relative to the reference axis and the reference plane, whether a lamp complies with the requirements.

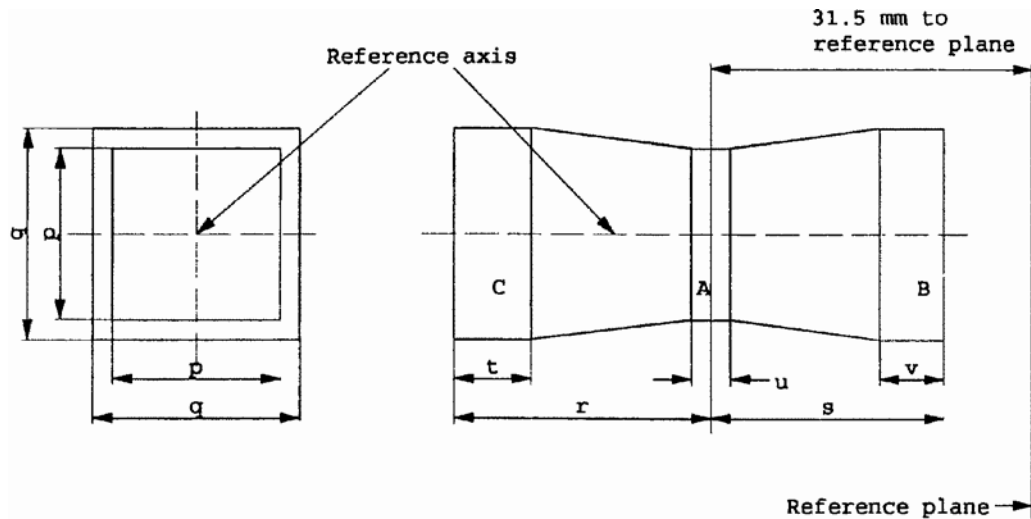

	p	q	r	s	t	u	v
12 V	1.3 d	1.6 d	3.0	2.9	0.9	0.4	0.7

d = diameter of filament

The filament position is checked solely in directions A and B as shown on sheet HB3/1.

The beginning of the filament as defined on sheet HB3/3, note <sup>11/</sup> shall be in volume "B" and the end of the filament in volume "C".

The filament shall lie entirely within the limits shown. Volume "A" does not involve any filament centre requirement.

**CATEGORIES HB4 AND HB4A**

Sheet HB4/1

The drawings are only to illustrate the essential dimensions of the filament lamp

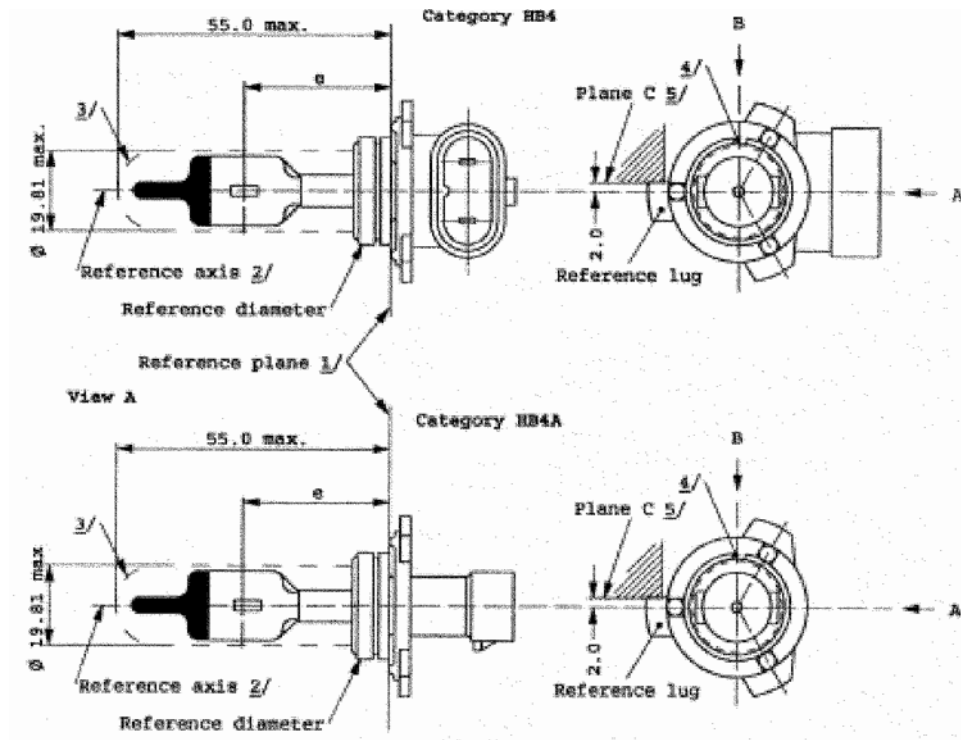

- 1/ The reference plane is the plane defined by the meeting points of the cap-holder fit.
- 2/ The reference axis is perpendicular to the reference plane and concentric with the reference diameter of the cap.
- 3/ Glass bulb and supports shall not exceed the envelope and shall not interfere with insertion past the lamp key. The envelope is concentric to the reference axis.
- 4/ The keyway is mandatory.
- 5/ The filament lamp shall be rotated in the measuring holder until the reference lug contacts plane C of the holder.

**CATEGORIES HB4 AND HB4A**

Sheet HB4/2

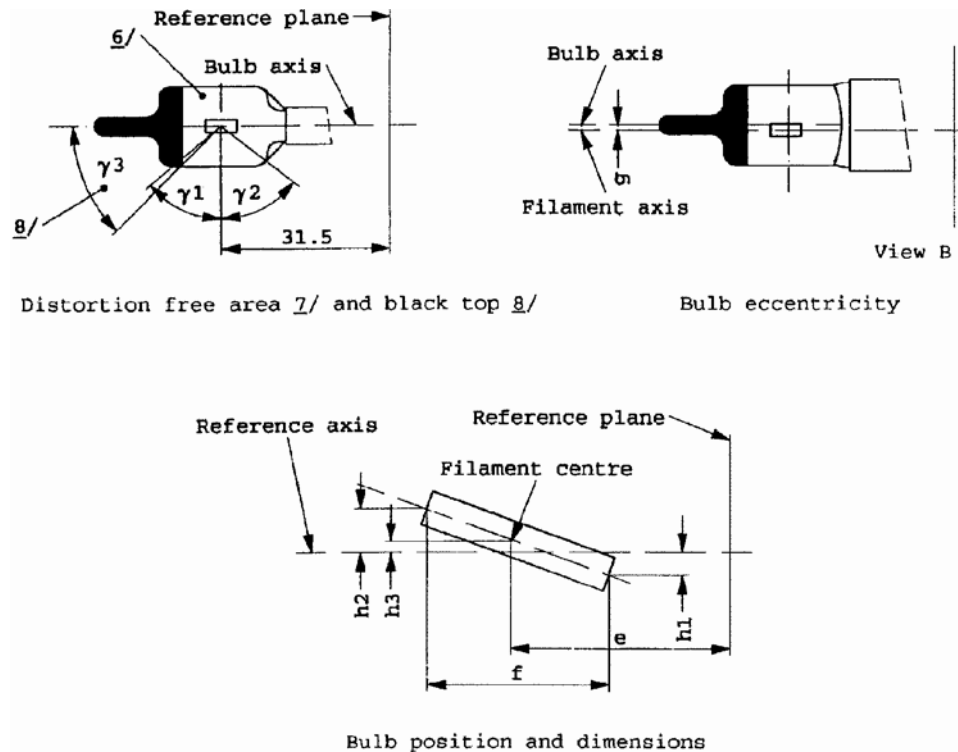

6/ The bulb shall be colourless or yellow.

7/ Glass bulb periphery shall be optically distortion-free axially within the angles  $\gamma_1$  and  $\gamma_2$ . This requirement applies to the whole bulb circumference within the angles  $\gamma_1$  and  $\gamma_2$ .

8/ The obscuration shall extend to at least angle  $\gamma_3$  and shall be at least as far as the undistorted part of the bulb defined by angle  $\gamma_1$ .

**CATEGORIES HB4 AND HB4A**

Sheet HB4/3

Dimensions in mm		Tolerances	
<sup>13/</sup>		Filament lamps of normal production	Standard filament lamp
e <sup>10/</sup> 12	31.5	11	+/- 0.16
f <sup>10/</sup> 12	5.1	11	+/- 0.16
h1, h2	0	11	+/- 0.15
h3	0	11	+/- 0.08
g <sup>10/</sup>	0.75	+/- 0.5	+/- 0.3
gamma <sub>1</sub>	50 degrees min.	-	-
gamma <sub>2</sub>	52 degrees min.	-	-
gamma <sub>3</sub>	45 degrees	+/- 5 degrees	+/- 5 degrees
Cap P 22d in accordance with IEC 61 (sheet 7004-32-2) <sup>14/</sup>			
<b>ELECTRICAL AND PHOTOMETRIC CHARACTERISTICS</b>			
Rated values	V	12	12
	W	51	51
Test voltage	V	13.2	13.2
Objective values	W	62 max.	62 max.
	Luminous flux 1m +/- %	1,095	
		15	
Reference luminous flux for headlamp testing: 825 1m at approx. 12V			

13/

Dimensions shall be checked with O-ring removed.

11/

To be checked by means of a "box-system". Sheet HB4/4. <sup>\*/</sup>

12/

The ends of the filament are defined as the points where, when the viewing direction <sup>\*/</sup> as defined in note <sup>10/</sup> above, the projection of the outside of the end turns crosses the filament axis.

<sup>\*/</sup>

Manufacturers may choose another set of perpendicular viewing directions. The viewing directions specified by the manufacturer are to be used by the testing laboratory when checking filament dimensions and position.

9/

The eccentricity is measured only in viewing directions <sup>\*/</sup> A and B as shown in the figure on sheet HB4/1. The points to be measured are those where the projection of the outside of the end turns nearest to or furthest from the reference plane crosses the filament axis.

10/

The viewing direction is direction <sup>\*/</sup> B as shown in the figure on sheet HB4/1.

14/

Filament lamp HB4 shall be equipped with the right-angle cap and filament lamp HB4A with the straight cap.

**CATEGORIES HB4 AND HB4A**

Sheet HB4/4

**Screen projection requirements**

This test is used to determine, by checking whether the filament is correctly positioned relative to the reference axis and the reference plane, whether a filament lamp complies with the requirements.

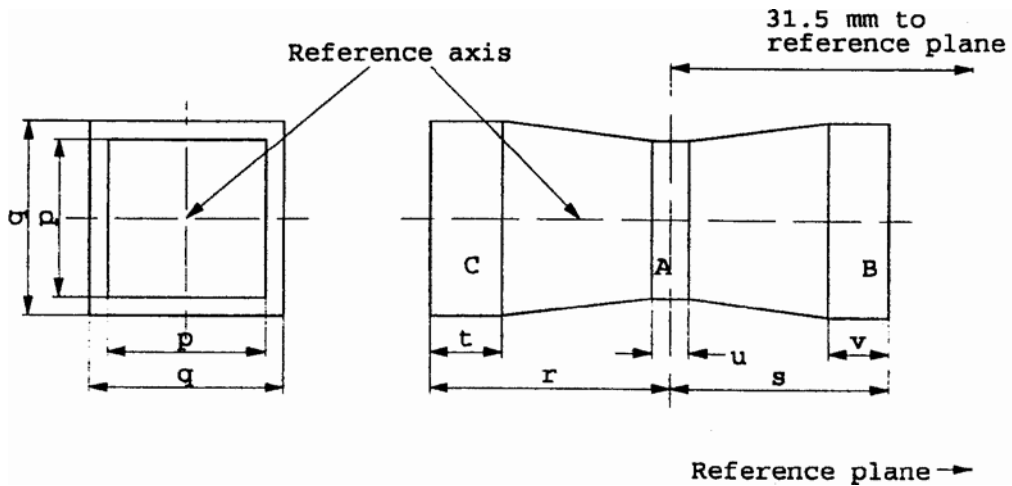

	p	q	r	s	t	u	v
12 V	1.3 d	1.6 d	3.0	2.9	0.9	0.4	0.7

d = diameter of filament

The filament position is checked solely in directions A and B as shown on sheet HB4/1.

The beginning of the filament as defined on sheet HB4/3, note <sup>12/</sup> shall be in volume "B" and the end of the filament in volume "C".

The filament shall lie entirely within the limits shown. Volume "A" does not involve any filament centre requirement.

**CATEGORY T1.4W**

Sheet T1.4W/1

The drawings are intended only to illustrate the essential dimensions of the filament lamp

Dimensions in mm

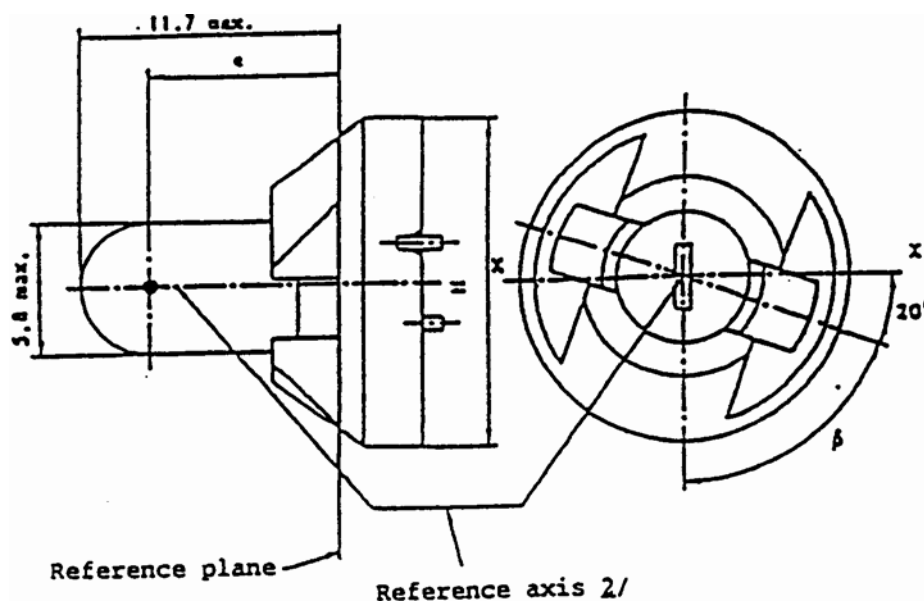

Dimensions in mm	Filament lamps of normal production			Standard filament lamp
	min.	nom.	max.	
e	7.6	8.3	9.0	8.3 +/- 0.35
Lateral deviation <sup>1/</sup>			0.7	0.35 max.
beta	55 degrees	70 degrees	85 degrees	70 degrees +/- 5 degrees
Cap P11.5d in accordance with IEC Publication 61 (sheet 7004-79-1)				
<b>ELECTRICAL AND PHOTOMETRIC CHARACTERISTICS</b>				
Rated values	V	12		12
	W	1.4		
Test voltage	V	13.5		13.5
Objective values	W	1.4		1.4 at 13.5 V
	+/- %	10		10
	Luminous flux lm +/- %	8 15		
Reference luminous flux: 8 lm at approx. 13.5 V				

1/ Maximum lateral deviation of filament centre from two mutually perpendicular planes both containing reference axis and one containing axis X-X

2/ The reference axis is the line perpendicular to the reference plane and passing through the centre of the circle of diameter "M".

**CATEGORY H7**

Sheet H7/1

The drawings are intended only to illustrate the essential dimensions of the filament lamp.

Dimensions in mm

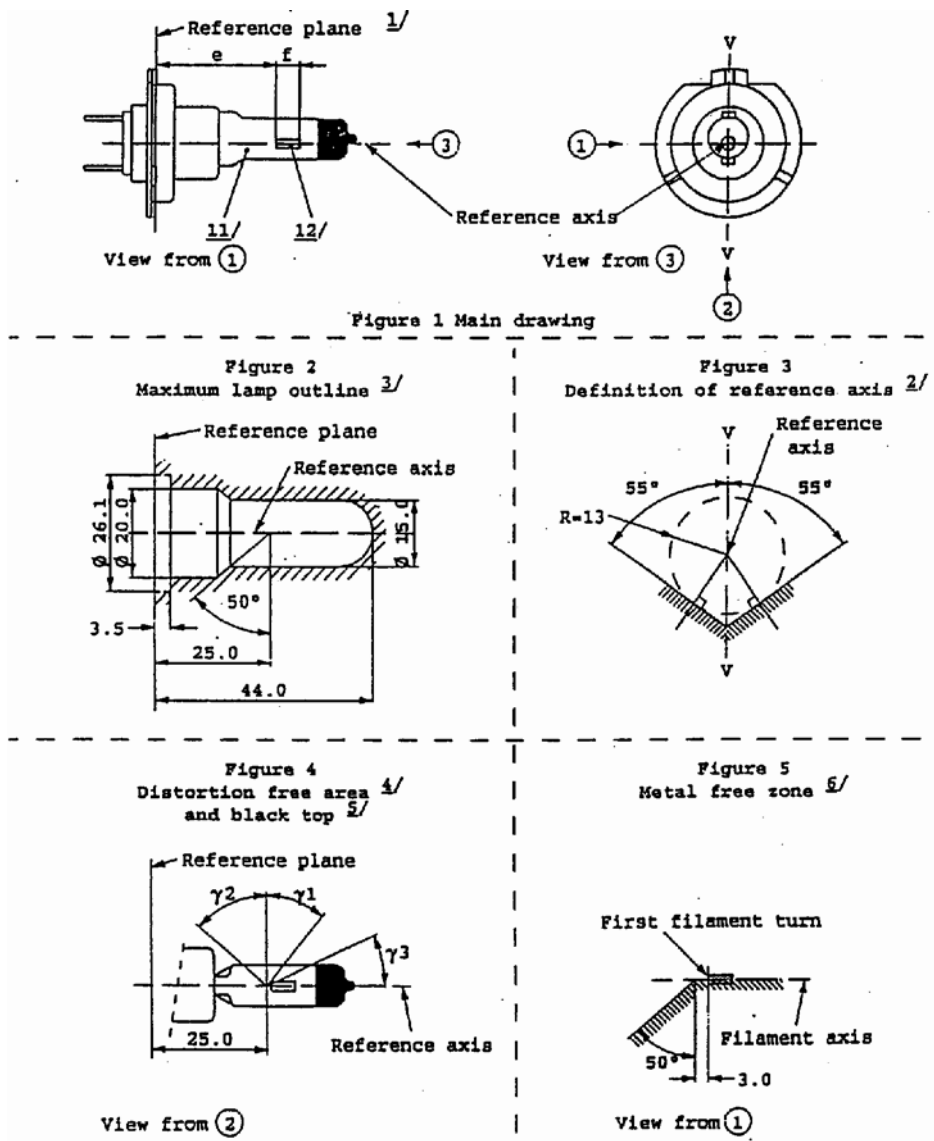



**CATEGORY H7**

Sheet H7/2

Figure 6  
 Permissible offset of filament axis  
 (For standard filament lamps only) 2/

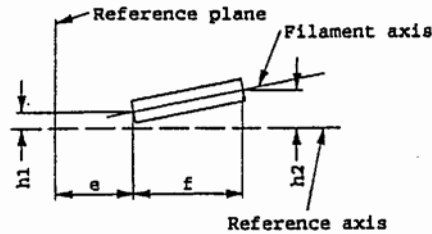
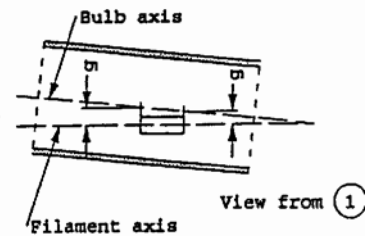

Figure 7  
 Bulb eccentricity 10/



Dimensions in mm	Filament lamp of normal production		Standard filament lamp	
	12 V	24 V	12 V	
e <sup>7/</sup>	25.0 <sup>8/</sup>		25.0 +/- 0.1	
f <sup>7/</sup>	4.5	4.9 <sup>8/</sup>	4.1 +/- 0.1	
g <sup>10/</sup>	0.5 min.		u.c.	
h1 <sup>9/</sup>	0 <sup>8/</sup>		0 +/- 0.1	
h2 <sup>9/</sup>	0 <sup>8/</sup>		0 +/- 0.15	
gamma <sub>1</sub> <sup>4/</sup>	40 degrees min.		40 degrees min.	
gamma <sub>2</sub> <sup>4/</sup>	50 degrees min.		50 degrees min.	
gamma <sub>3</sub> <sup>5/</sup>	30 degrees min.		30 degrees min.	
Cap PX26d in accordance with IEC Publication 61 (sheet 7004-5-1)				
<b>ELECTRICAL AND PHOTOMETRIC CHARACTERISTICS</b>				
Rated values	Volts	12	24	12
	Watts	55	70	55
Test voltage	Volts	13.2	28.0	13.2
Objective values	Watts	58 max.	75 max.	58 max.
	Luminous Flux lm +/- %	1500	1750	
		10	10	
Reference luminous flux for headlamp testing: 1100 lm at approx. 12 V				

---

**CATEGORY H7**

**Sheet H7/3**

- 1/ The reference plane is defined by the points on the surfaces of the holder on which the three supporting bosses of the cap ring will rest.
- 2/ The reference axis is perpendicular to the reference plane and crosses the intersection of the two perpendiculars as indicated in figure 3 on Sheet H7/1.
- 3/ Glass bulb and supports shall not exceed the envelope as indicated in figure 2 on sheet H7/1. The envelope is concentric to the reference axis.
- 4/ Glass bulb shall be optically distortion free within the angles  $\gamma_1$  and  $\gamma_2$ . This requirement applies to the whole bulb circumference within the angles  $\gamma_1$  and  $\gamma_2$ .
- 5/ The obscuration shall extend at least to angle  $\gamma_3$  and shall extend at least to the cylindrical part of the bulb on the whole bulb top circumference.
- 6/ The internal design of the lamp shall be such that stray light images and reflections are only located above the filament itself seen from the horizontal direction. (View (1) as indicated in figure 1 on sheet H7/1). No metal parts other than filament turns shall be located in the shaded area as seen in figure 5 on Sheet H7/1.
- 7/ The end of the filaments are defined as the points where, when the viewing direction is direction (1) as shown in figure 1 on Sheet H7/1, the projection of the outside of the end turns crosses the filament axis. (Special instructions for coiled-coil filaments are under consideration)
- 8/ To be checked by means of a "Box system". Sheet H7/4.
- 9/ The offset of the filament with respect to the reference axis is measured only in viewing directions (1) and (2) as shown in figure 1 on Sheet H7/1. The points to be measured are those where the projection of the outside of the end turns nearest to or furthest from the reference plane crosses the filament axis.
- 10/ Offset of filament in relation to bulb axis measured in two planes parallel to the reference plane where the projection of the outside of the end turns nearest to or furthest from the reference plane crosses the filament axis.
- 11/ The bulb shall be colourless or selective-yellow.
- 12/ Notes concerning the filament diameter
  - No actual diameter restrictions apply but the objective for future developments is to have  $d_{max} = 1.3\text{mm}$  for 12V and  $d_{max} = 1.7\text{mm}$  for 24V filament lamps.
  - For the same manufacturer the design diameter of standard (etalon) filament lamp and filament lamp of normal production shall be the same.

**CATEGORY H7**

Sheet H7/4

**Screen projection requirements**

This test is used to determine, by checking whether the filament is correctly positioned relative to the reference axis and the reference plane, whether a filament lamp complies with the requirements.

Dimensions in mm

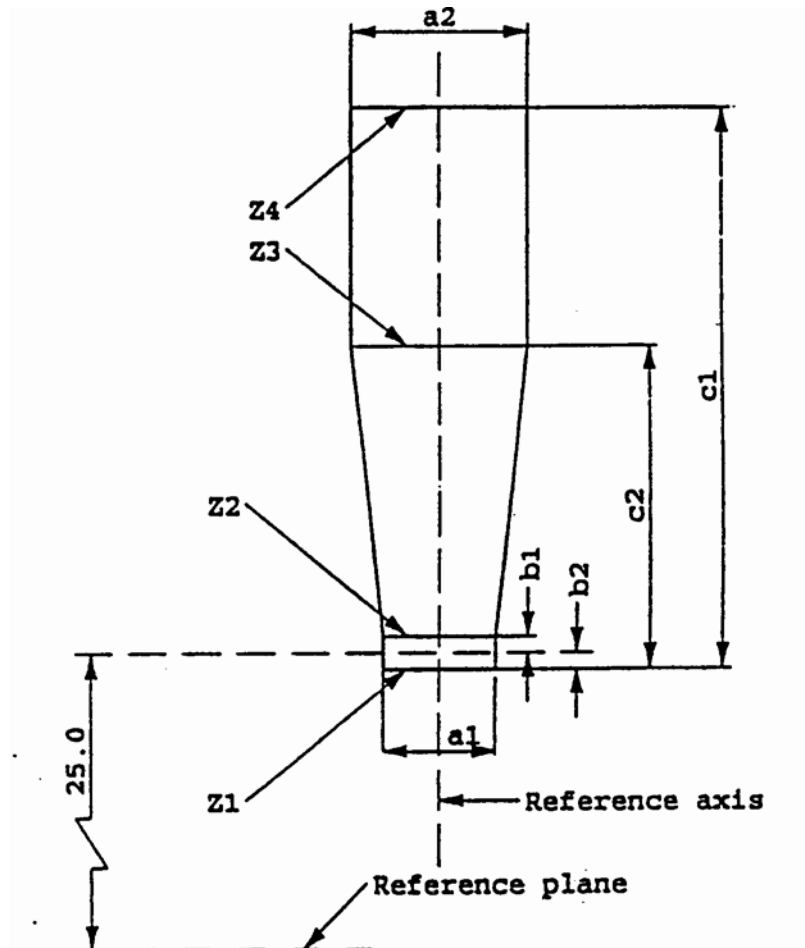

	$a_1$	$a_2$	b	b	$c_1$	$c_2$
12 V	$d + 0.30$	$d + 0.50$	<sup>1</sup>	0.2 <sup>2</sup>	4.6	4.0
24 V	$d + 0.60$	$d + 1.00$	0.25		5.9	4.4

$d$  = diameter of filament

The ends of the filament as defined on sheet H7/3, footnote 7/, must lie between lines  $Z_1$  and  $Z_2$  and between lines  $Z_3$  and  $Z_4$ .

The filament position is checked solely in directions (1) and (2) as shown on sheet H7/1, figure 1.

The filament must lie entirely within the limits shown.

**CATEGORIES H27W/1 AND H27W/2**

Sheet H27W/1

The drawings are intended only to illustrate the essential dimensions of the filament lamp.

**Category H27W/1**

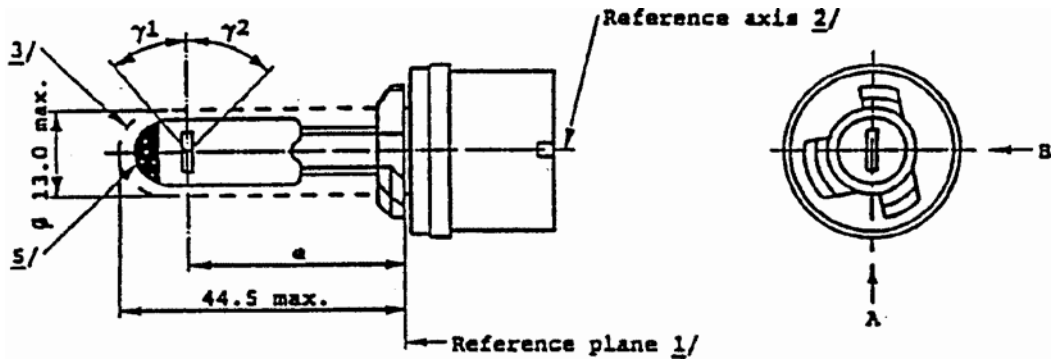

**Category H27W/2**

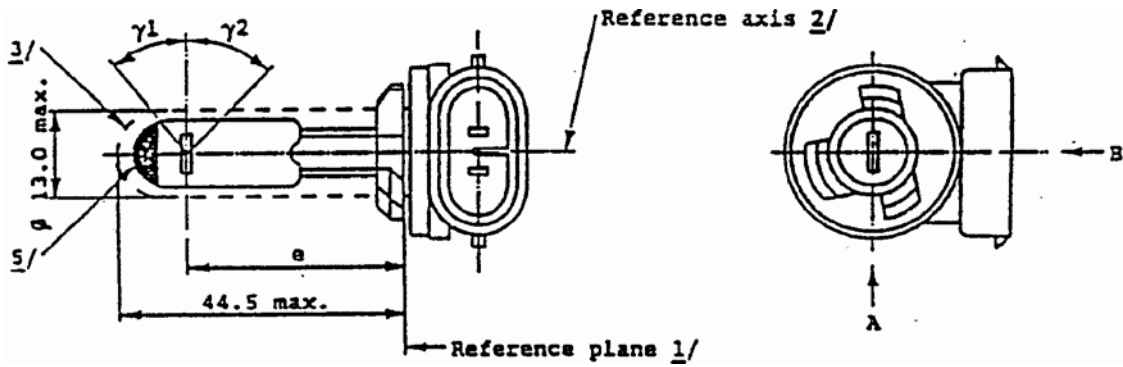

Filament dimensions and position  
 (Dimension f for all filament lamps)  
 (Dimensions  $h_1$ ,  $h_2$ ,  $h_3$ ,  $h_4$  and k for standard filament lamps only)

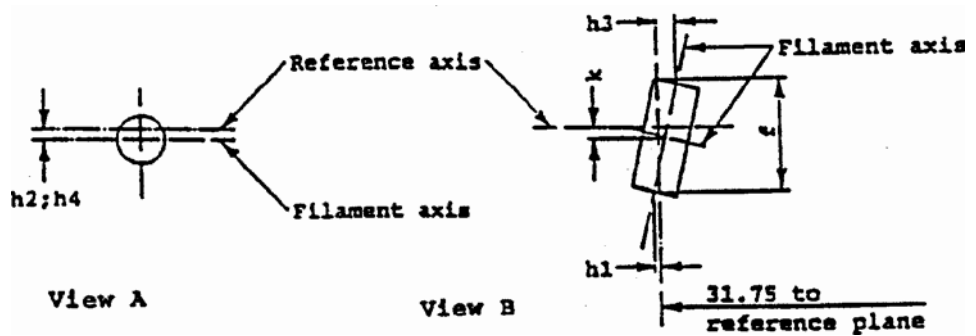

**CATEGORIES H27W/1 AND H27W/2**

Sheet H27W/2

Dimensions in mm	Filament lamps of normal production		Standard filament lamp
	12 V		12 V
e	31.75 <sup>6/</sup>		31.75 +/- 0.25
f <sup>8/</sup>	4.8 max.		4.2 +/- 0.2
k	0 <sup>6/</sup>		0.0 +/- 0.25
h <sub>1</sub> ; h <sub>3</sub> <sup>7/</sup>	0 <sup>6/</sup>		0.0 +/- 0.25
h <sub>2</sub> ; h <sub>4</sub> <sup>7/</sup>	0 <sup>6/</sup>		0.0 +/- 0.25
gamma <sub>1</sub> <sup>4/</sup>	38 degrees nom.		38 degrees nom.
gamma <sub>2</sub> <sup>4/</sup>	44 degrees min.		44 degrees min.
H27W/1: PG 13 Cap in accordance with IEC Publ. 61 (sheet 7004-107-1) H27W/2: PGJ13			
<b>ELECTRICAL AND PHOTOMETRIC CHARACTERISTICS</b>			
Rated values	Volts	12	12
	Watts	27	27
Test voltage	Volts	13.5	13.5
Objective values	Watts	31 max.	31 max.
	Luminous Flux lm +/- %	477 15	
Reference luminous flux: 477lm at approx. 13.5V			

- <sup>1/</sup>The reference plane is the plane formed by the underside of the bevelled lead-in flange of the cap.  
<sup>2/</sup> The reference axis is perpendicular to the reference plane and passing through the centre of the 13.10mm cap diameter.  
<sup>3/</sup> Glass bulb and supports shall not exceed the size of a theoretical cylinder centred on the reference axis.  
<sup>4/</sup> Glass bulb shall be optically distortion-free within the angles gamma<sub>1</sub> and gamma<sub>2</sub>. This requirement applies to the whole bulb circumference within the angles gamma<sub>1</sub> and gamma<sub>2</sub>.  
<sup>5/</sup> The obscuration shall extend over the whole bulb top including the bulb cylindrical portion up to the intersection with gamma<sub>1</sub>.  
<sup>6/</sup> To be checked by means of a "Box system" . Sheet 27W/3.  
<sup>7/</sup> For standard filament lamps, the points to be measured are those where the projection of the outside of the end turns crosses the filament axis.  
<sup>8/</sup> The ends of the filament are defined by the intersections of the outsides of the first and of the last light emitting turn, respectively, with the plane parallel to and 31.75mm from the reference plane.

**CATEGORIES H27W/1 AND H27W/2**

Sheet H27W/3

**Screen projection requirements**

This test is used to determine, by checking the correctness of the filament relative to the reference axis and reference plane, whether a filament lamp complies with the requirements.

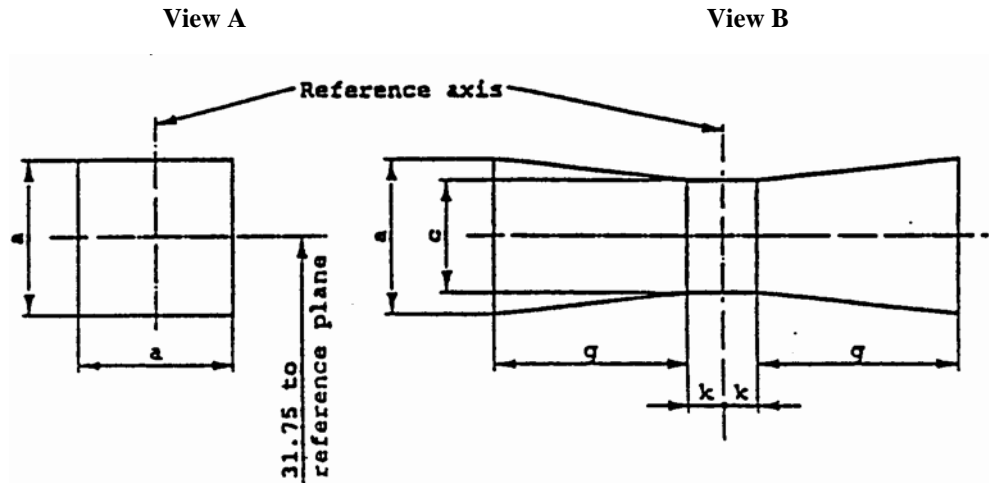

Reference	a	c	k	g
Dimensions	$d + 1.2$	$d + 1.0$	0.5	2.4

$d$  = actual filament diameter

The filament shall lie entirely within the limits shown.

The centre of the filament shall lie within the limits of dimension  $k$ .

**CATEGORY P27W**

Sheet P27W/1

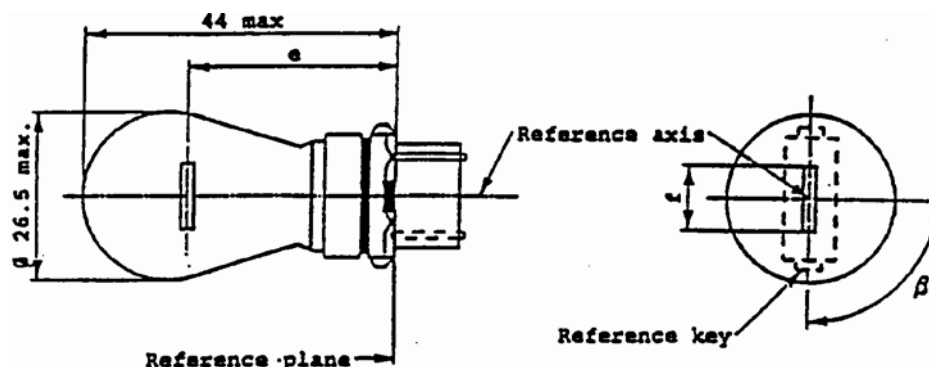

Dimensions in mm	Filament lamps of normal production			Standard filament lamp
	min.	nom.	max.	
e		27.9 <sup>3/</sup>		27.9 +/- 0.3
f			9.9	9.9 + 0 - 2
Lateral deviation <sup>2/</sup>			3/	0.0 +/- 0.4
beta	75 degrees <sup>3/</sup>	90 degrees	105 degrees <sup>3/</sup>	90 degrees +/- 5 degrees
Cap W2.5x16d in accordance with IEC Publ. 61 (sheet 7004-104-1)				
<b>ELECTRICAL AND PHOTOMETRIC CHARACTERISTICS</b>				
Rated values	V	12		12
	W	27		27
Test voltage	V	13.5		
Objective values	Watts	W	29.2	29.2 at 13.5V
		+/- %	10	10
	Luminous flux	lm	475	
		+/- %	15	
Reference luminous flux: 475lm at approx. 13.5V				

- 1/ The reference axis is defined with respect to the reference keys and is perpendicular to the reference plane.
- 2/ Maximum lateral deviation of filament centre from two mutually perpendicular planes both containing the reference axis and one containing axis through reference keys.
- 3/ To be checked by means of a box system, sheet P27W/2

**CATEGORY P27W**

Sheet P27W/2

**Screen projection requirements**

This test is used to determine, by checking whether the filament is correctly positioned relative to the reference axis and the reference plane and has an axis perpendicular, within +/- 15 degrees, to the plane through the centres of the keys and the reference axis, whether a filament lamp complies with the requirements.

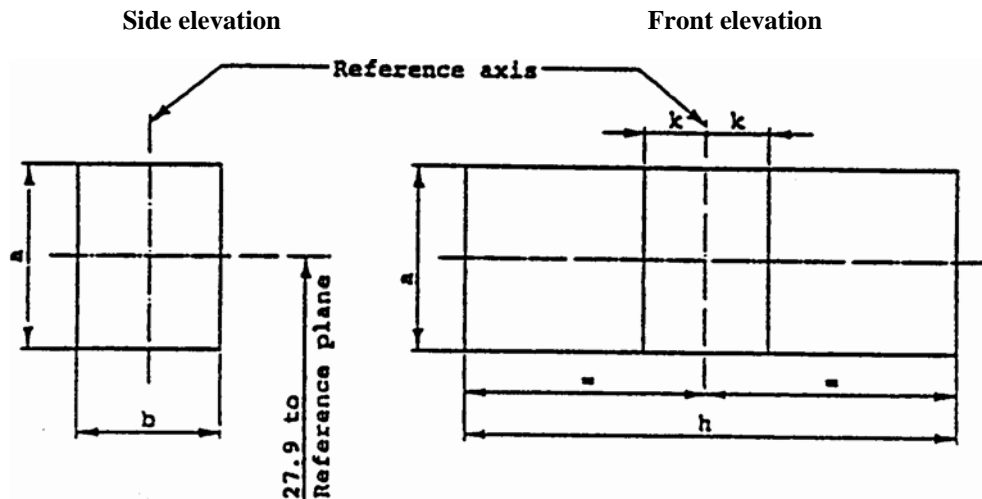

Reference	a	b	h	k
Dimension	3.5	3.0	11.9	1.0

Test procedures and requirements.

1. The filament lamp is placed in a holder capable of being rotated about its axis and having either a calibrated scale or fixed stops corresponding to the angular displacement tolerance limits. The holder is then so rotated that an end view of the filament is seen on the screen on to which the image of the filament is projected. The end view of the filament shall be obtained within the angular displacements tolerance limits.

**2. Side elevation**

The filament lamp placed with the cap down, the reference axis vertical and the filament seen end-on, the projection of the filament shall lie entirely within a rectangle of height "a" and width "b", having its centre at the theoretical position of the centre of the filament.

**3. Front elevation**

The filament lamp placed with the cap down and the reference axis vertical, the filament lamp being viewed in a direction at right angles to the filament axis:

- 3.1. The projection of the filament shall lie entirely within a rectangle of height "a" and width "h", having its centre at the theoretical position of the centre of the filament.
- 3.2. The centre of the filament shall not be offset by more than distance "k" from the reference axis.



**CATEGORY P27/7W**

Sheet P27W/7W/1

a = major (high wattage) filament

b = minor (low wattage) filament

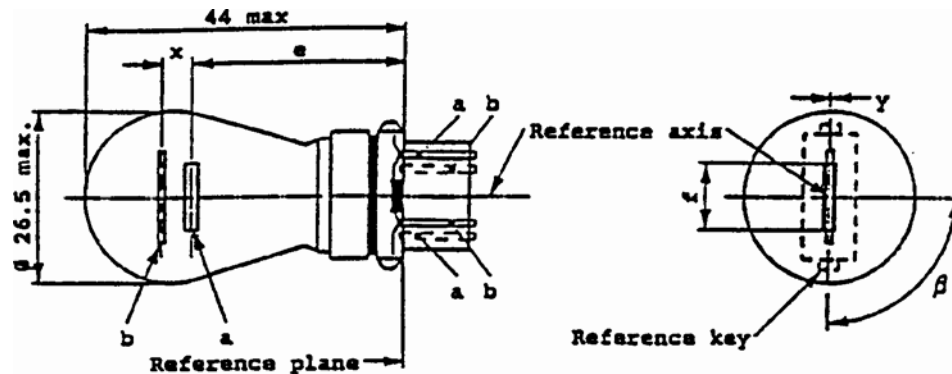

DIMENSIONS in mm	Filament lamps of normal production			Standard filament lamp		
	min.	nom.	max.			
e		27.9 <sup>3/</sup>		27.9 +/- 0.3		
f			9.9	9.9	+0 -2	
Lateral deviation <sup>2/</sup>			3/	0.0 +/- 0.4		
x <sup>4/</sup>		5.1 <sup>3/</sup>		5.1 +/- 0.5		
y <sup>4/</sup>		0.0 <sup>3/</sup>		0.0 +/- 0.5		
beta	75 degrees <sup>3/</sup>	90 degrees	105 degrees <sup>3/</sup>	90 degrees +/- 5 degrees		
Cap W2.5x16q in accordance with IEC Publ. 61 (7004-104-1)						
<b>ELECTRICAL AND PHOTOMETRIC CHARACTERISTICS</b>						
Rated values		V	12		12	
		W	27	7	27	7
Test voltage		V	13.5			
Objective values	Watts	W	29.2	7.7	29.2	7.7
						at 13.5 V
	Luminous flux	+/- %	10		10	
		lm	475	36		
		+/- %	15			

Reference luminous flux: 475 and 36lm at approx. 13.5V

- 1/ The reference axis is defined with respect to the reference keys and is perpendicular to the reference plane.  
 2/ Maximum lateral deviation of major (high wattage) filament centre from two

- 3/ mutually perpendicular planes both containing the reference axis and one containing axis through reference keys.
- 4/ To be checked by means of a box system, sheets P27W/2 & 3.  
"x" and "y" denote the offset of the axis of the minor (low wattage) filament with respect to the axis of the major (high wattage) filament.

---

**CATEGORY P27/7W**

Sheet P27W/7W/2

Screen projection requirements

This test is used to determine, by checking whether:

- (a) the major (high wattage) filament is correctly positioned relative to the reference axis and reference plane and has an axis perpendicular, within +/- 15 degrees, to the plane through the centres of the keys and the reference axis; and whether:
- (b) the minor (low wattage) filament is correctly positioned relative to the major (high wattage) filament,

whether a filament lamp complies with the requirements.

Test procedures and requirements.

**1.** The filament lamp is placed in a holder capable of being rotated about its axis and having either a calibrated scale or fixed stops corresponding to the angular displacement tolerance limits. The holder is then so rotated that an end view of the major filament is seen on the screen on to which the image of the filament is projected. The end view of that filament shall be obtained within the angular displacement tolerance limits.

**2. Side elevation**

The filament lamp placed with the cap down, the reference axis vertical, the reference key to the right and the major filament seen end-on:

2.1. the projection of the major filament shall lie entirely within a rectangle of height "a" and width "b", having its centre at the theoretical position of the centre of the filament;

2.2. the projection of the minor filament shall lie entirely within a rectangle of width "c" and height "d" having its center at a distance "u" above the theoretical position of the centre of the major filament.

**3. Front elevation**

The filament lamp placed with the cap down and the reference axis vertical, the filament lamp being viewed in a direction at right angles to the axis of the major filament:

3.1. the projection of the major filament shall lie entirely within a rectangle of height "a" and width "h", centred on the theoretical position of the centre of the filament;

3.2. the centre of the major filament shall not be offset by more than distance "k" from the reference axis;

3.3. the centre of the minor filament shall not be offset from the reference axis by more than +/- 2mm (+/- 0.4mm for standard filament lamps).

**CATEGORY P7/W**

Sheet P27/7W/3

Side elevation

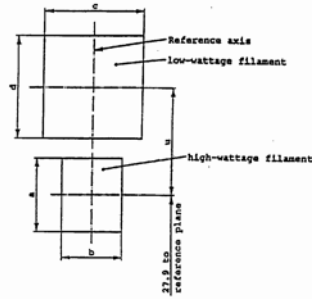

Reference	a	b	c	d	u
Dimensions	3.5	3.0	4.8	5.1	

Front elevation

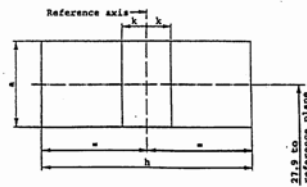

Reference	a	h	k
Dimensions	3.5	11.9	1.0

**CATEGORY WY5W**

Sheet WY5W/1

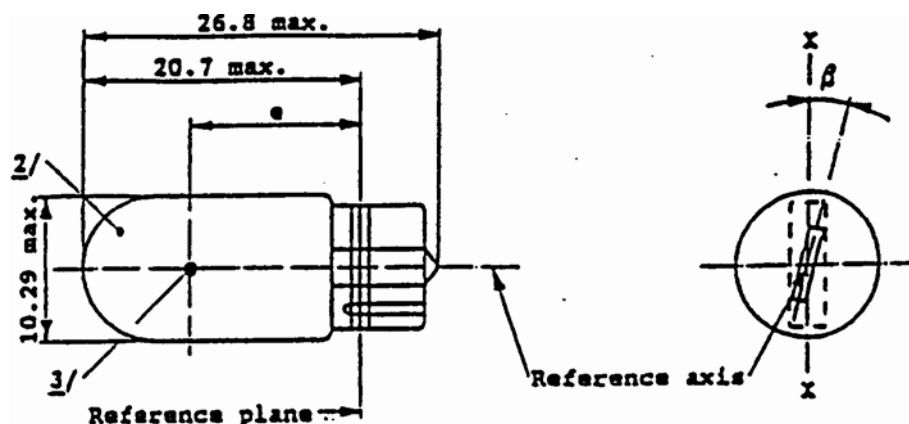

DIMENSIONS in mm		Filament lamps of normal production			Standard <sup>4/</sup> filament lamp	
		min.	nom.	max.		
e		11.2	12.7	14.2	12.7 +/- 0.3	
Lateral deviation <sup>1/</sup>				1.5	0.5 max.	
beta		-15 degrees	0 degrees	+15 degrees	0 degrees +/- 5 degrees	
Cap W 2.1 x 9.5d in accordance with IEC Publ. 61 (7004-91-3)						
ELECTRICAL AND PHOTOMETRIC CHARACTERISTICS						
Rated values		V	6	12	24	12
		W	5			5
Test voltage		V	6.75	13.5	28.0	
Objective values	Watts	W	5		7	5 at 13.5V
		+/-%	10			10
	Luminous flux	lm	30			
		+/-%	20			
Amber bulb: 30lm Reference luminous flux: at approx. 13.5V Clear bulb: 50lm						

- 1/ Maximum lateral deviation of filament centre from two mutually perpendicular planes both containing the reference axis and one containing the axis XX.  
 2/ The bulb of production lamps shall be amber. (See also note <sup>4/</sup>).  
 3/ See paragraph 3.5.3.  
 4/ The bulb of standard filament lamps shall be amber or clear. For amber standard filament lamps, changes of the bulb temperature shall not affect the luminous flux which might impair photometric measurements of signalling devices. Moreover the colour shall be in the lower part of the tolerance area.

**CATEGORY H21W**

Sheet H21W/1

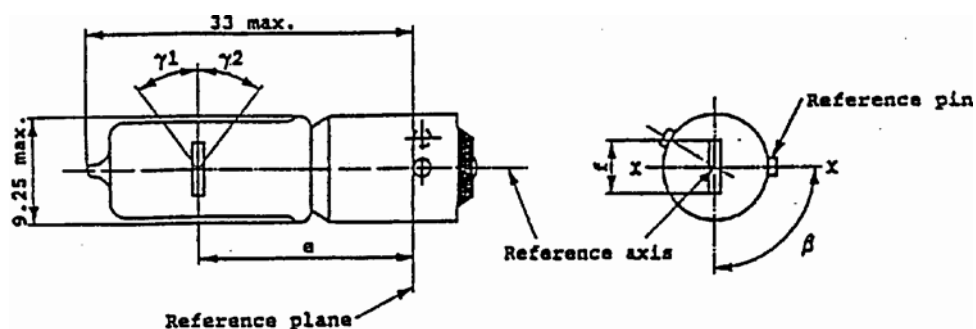

Dimensions in mm		Filament lamps of normal production			Standard filament lamp
		min.	nom.	max.	
e			20.0 <sup>1/</sup>		20.0 +/- 0.25
f	12 V			3.8	3.8 + 0 - 1
	24 V			4.5	
Lateral deviation <sup>2/</sup>				1/	0.0 +/- 0.15
beta		82.5 degrees	90 degrees	97.5 degrees	<sup>3/</sup> 90 degrees +/- 5 degrees
gamma <sub>1</sub> , gamma <sub>2</sub> <sup>4/</sup>		45 degrees			45 degrees min.
Cap BAY9s: in accordance with IEC Publ. 61 (sheet 7004-9-1)					
ELECTRICAL AND PHOTOMETRIC CHARACTERISTICS					
Rated values		V	12	24	12
		W	21	21	6
Test voltage		V	13.5	28	
Objective values	Watts	W	25	28	25 at 13.5V
		+/- %	5	5	5
	Luminous flux	lm	600	600	
		+/- %	12	15	
Reference luminous flux: 600lm at approx. 13.5V					

1/ To be checked by means of a box system, sheet H21W/2.

2/ Maximum lateral deviation of filament centre from two mutually perpendicular planes both containing the reference axis and one containing the axis X-X.

3/ The lateral deviation with respect to the plane perpendicular to axis XX, is measured in the position described in clause 1 of the test procedures on sheet H21W/2.

4/ In the area between the outer legs of the angles gamma<sub>1</sub> and gamma<sub>2</sub>, the bulb shall have no optically distorting areas and the curvature of the bulb shall have a radius not less than 50% of the actual bulb diameter.

**CATEGORY H21W**

Sheet H21W/2

**Screen projection requirements**

This test is used to determine, by checking whether the filament is correctly positioned relative to the reference axis and the reference plane and has an axis perpendicular, within +/- 7.5 degrees, to the plane through the centre line of the reference pin and the reference axis, whether a filament lamp complies with the requirements.

**Side elevation**

**Front elevation**

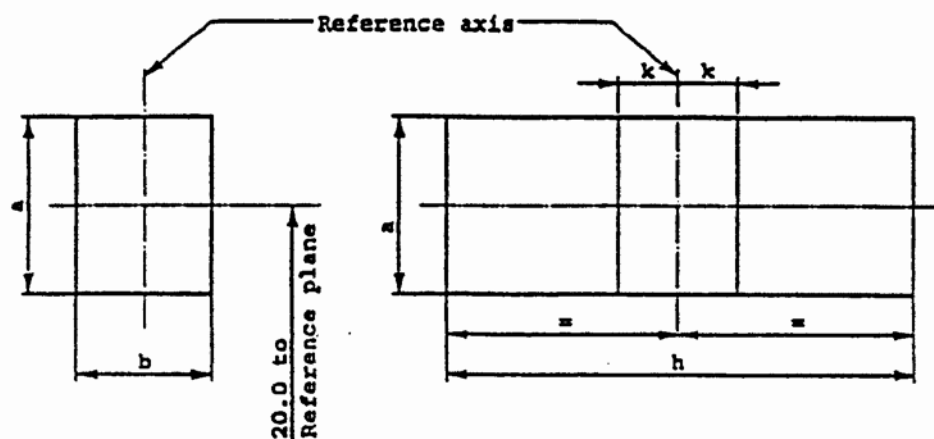

Reference	a	b	h	k
Dimension	d + 1.0	d + 1.0	f + 1.2	0.5

d = actual filament diameter

f = actual filament length

Test procedures and requirements

1. The filament lamp is placed in a holder capable of being rotated about its axis and having either a calibrated scale or fixed stops corresponding to the angular displacement tolerance limits. The holder is then so rotated that an end view of the filament is seen on the screen on to which the image of the filament is projected. The end view of the filament shall be obtained within the angular displacements tolerance limits.
2. **Side elevation**  
 The filament lamp placed with the cap down, the reference axis vertical and the filament seen end-on, the projection of the filament shall lie entirely within a rectangle of height "a" and width "b", having its centre at the theoretical position of the centre of the filament.
3. **Front elevation**  
 The filament lamp placed with the cap down and the reference axis vertical, the filament lamp being viewed in a direction at right angles to the filament axis:
  - 3.1. The projection of the filament shall lie entirely within a rectangle of height "a" and width "h", having its centre at the theoretical position of the centre of the filament.
  - 3.2. The centre of the filament shall not be offset by more than distance "k" from the

reference axis.



**CATEGORY W21W**

Sheet W21W/1

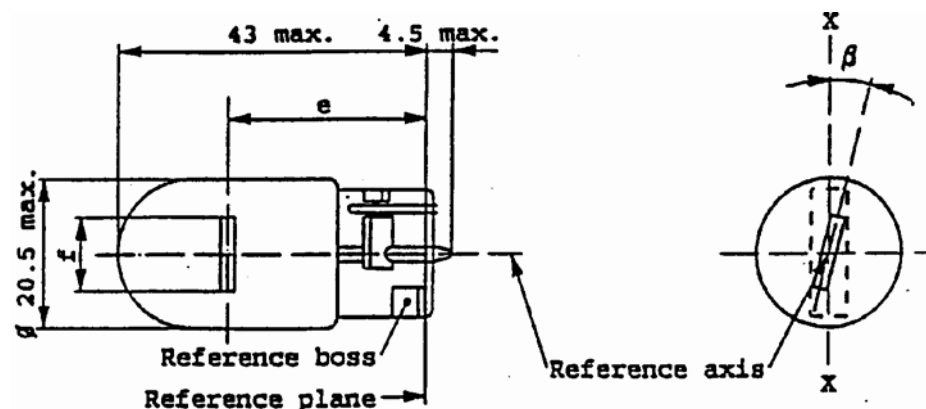

DIMENSIONS in mm	Filament lamps of normal production			Standard filament lamp
	min.	nom.	max.	
e		29.0		29.0 -0.3
f			7.5	7.5 +0 -2
Lateral deviation 1/			2/	0.5 max
beta	-15 degrees 2/	0 degrees	+15 degrees 2/	0 degrees +/- 5 degrees
Cap W 3x16d in accordance with IEC Publ. 61 (sheet 7004-105-2)				
<b>ELECTRICAL AND PHOTOMETRIC CHARACTERISTICS</b>				
Rated values	V		12	12
	W		21	21
Test voltage	V		13.5	
Objective values	W +/- %		25	25 at 13.5V
			6	6
	Luminous flux lm +/- %		460	
		15		
Reference luminous flux: 460lm at approx. 13.5V				

- 1/ Maximum lateral deviation of filament centre from two mutually perpendicular planes both containing the reference axis and one containing the axis X-X.  
 2/ To be checked by means of a box system, sheet W21W/2.

**CATEGORY W21W**

Sheet W21W/2

**Screen projection requirements**

This test is used to determine, by checking whether the filament is correctly positioned relative to the reference axis and the reference plane and has an axis perpendicular, within +/- 15 degrees, to the plane through the axis X-X and the reference axis, whether a filament lamp complies with the requirements.

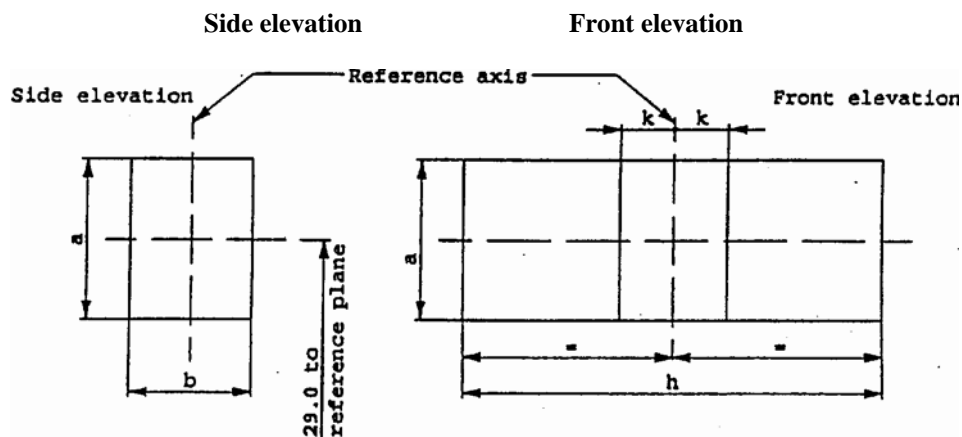

Reference	a	b	h	k
Dimension	3.5	3.0	9.5	1.0

**Test procedure and requirements**

1. The filament lamp is placed in a holder capable of being rotated about its axis and having either a calibrated scale or fixed stops corresponding to the angular displacement tolerance limits, i.e +/-15 degrees. The holder is then so rotated that an end view of the filament is seen on the screen on to which the image of the filament is projected. The end view of the filament shall be obtained within the angular displacements tolerance limits (+/- 15 degrees)
2. **Side elevation**  
  
The filament lamp placed with the cap down, the reference axis vertical and the filament seen end-on, the projection of the filament shall lie entirely within a rectangle of height "a" and width "b", having its centre at the theoretical position of the centre of the filament.
3. **Front elevation**  
  
The filament lamp placed with the cap down and the reference axis vertical, the filament lamp being viewed in a direction at right angles to the filament axis:
  - 3.1. the projection of the filament shall lie entirely within a rectangle of height "a" and width "h", having its center at the theoretical position of the centre of the filament;
  - 3.2. the centre of the filament shall not be offset by more than distance "k" from the reference axis.

**CATEGORY W21/5W**

Sheet W21/5W/1

a = major (high wattage) filament  
 b = minor (low wattage) filament

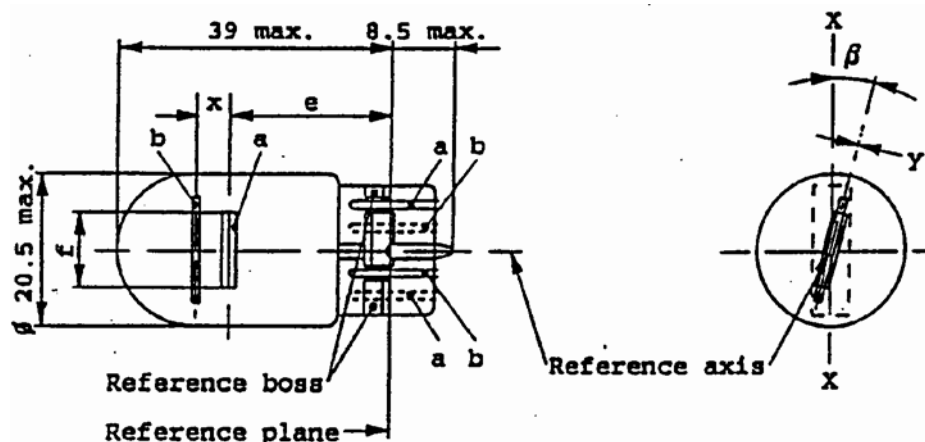

DIMENSIONS in mm	Filament lamps of normal production			Standard filament lamp		
	min.	nom.	max.			
e		25.0 <sup>1/</sup>		25.0 +/- 0.3		
f			7.5	7.5 +0 -2		
Lateral deviation <sup>2/</sup>			1/	0.3 max		
x <sup>3/</sup>		2.8 <sup>1/</sup>		2.8 +/- 0.3		
y <sup>3/</sup>		0.0 <sup>1/</sup>		0.0 +/- 0.3		
beta	- 15 degrees <sup>1/</sup>	0 degrees	+15 degrees <sup>1/</sup>	0 degrees +/- 5 degrees		
Cap W 3x16q in accordance with IEC Publ. 61 (sheet 7004-106-1)						
ELECTRICAL AND PHOTOMETRIC CHARACTERISTICS						
Rated values	V	12		12		
	W	21	5	21	5	
Test voltage	V	13.5				
Objective values	Watts	W	25	6	25	6
		+/--%	6	10	at 13.5V	
	Luminous flux	lm	440	35		
		+/--%	15	20		
Reference luminous flux: 440 and 35lm at approx. 13.5V						

1/To be checked by means of a box system, sheets W21/5W/2 and 3.

2/ Maximum lateral deviation of major filament centre from two mutually perpendicular planes both containing the reference axis and one containing axis X-X.

3/ "x" and "y" denote the offset of the axis of the minor filament with respect to the axis of the major filament.

---

**CATEGORY W21/5W**

Sheet W21/5W/2

Screen projection requirements

This test is used to determine, by checking whether:

- (a) the major filament is correctly positioned relative to the reference axis and reference plane and has an axis perpendicular, within +/- 15 degrees , to the plane through the axis X-X and the reference axis; and whether:
- (b) the minor filament is correctly positioned relative to the major

filament, whether a filament lamp complies with the requirements.

Test procedure and requirements

1. The filament lamp is placed in a holder capable of being rotated about its axis and having either a calibrated scale or fixed stops corresponding to the angular displacement tolerance limits. The holder is then so rotated that an end view of the major filament is seen on the screen on to which the image of the filament is projected. The end view of that filament shall be obtained within the angular displacement tolerance limits. (+/- 15 degrees ).

2. **Side elevation**

The filament lamp placed with the cap down, the reference axis vertical, and the major filament seen end-on.

2.1. the projection of the major filament shall lie entirely within a rectangle of height "a" and width "b", having its centre at the theoretical position of the centre of the filament;

2.2. the projection of the minor filament shall lie entirely within a rectangle of width "c" and height "d" having its centre at a distance "u" above the theoretical position of the centre of the major filament.

3. **Front elevation**

The filament lamp placed with the cap down and the reference axis vertical, the filament lamp being viewed in a direction at right angles to the axis of the major filament:

3.1. the projection of the major filament shall lie entirely within a rectangle of height "a" and width "h", centred on the theoretical position of the centre of the filament;

3.2. the centre of the major filament shall not be offset by more than distance "k" from the reference axis;

3.3. the centre of the minor filament shall not be offset from the reference axis by more than +/- 2mm (+/- 0.4mm for standard lamps).

**CATEGORY W21/5W**

Sheet W21/5W/3

**Side elevation**

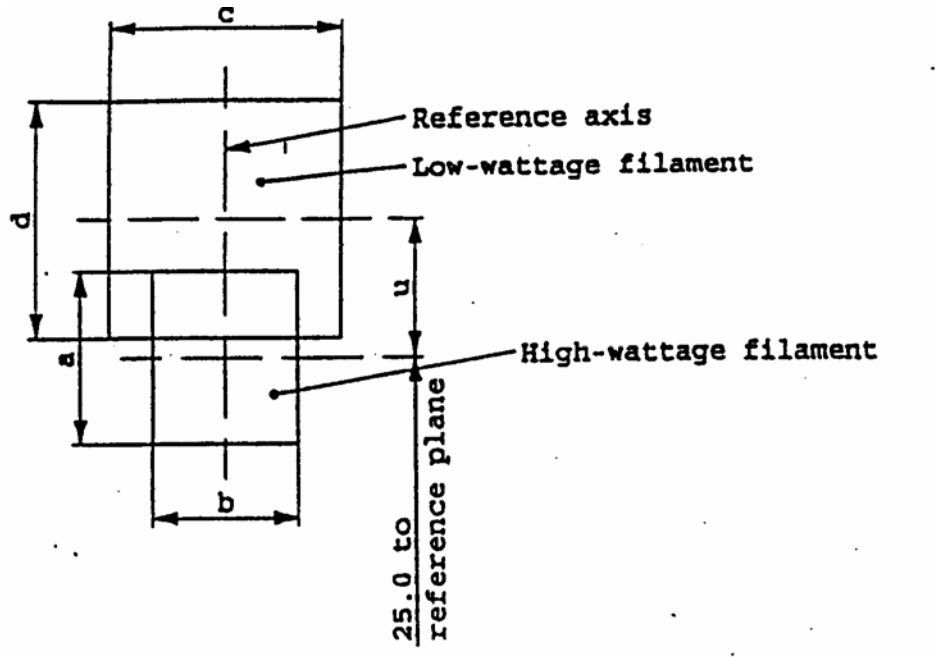

Reference	a	b	c	d	u
Dimensions	3.5	3.0	4.8		2.8

**Front elevation**

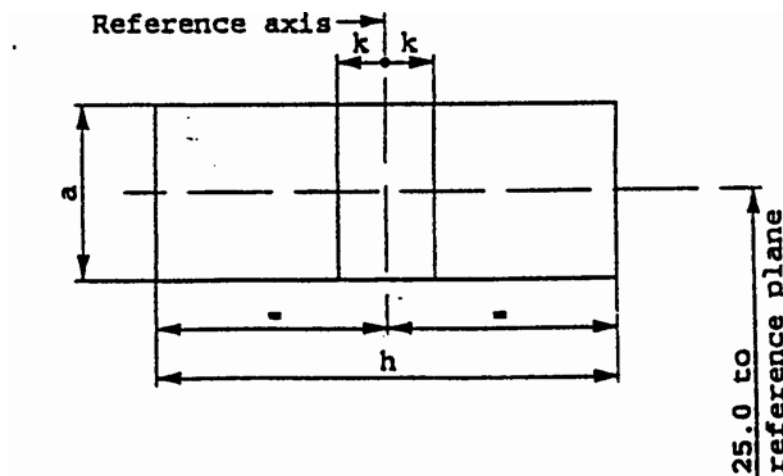

Reference	a	h	k
Dimensions	3.5	9.5	1.0

**CATEGORY W2.3W**

Sheet W2.3W/1

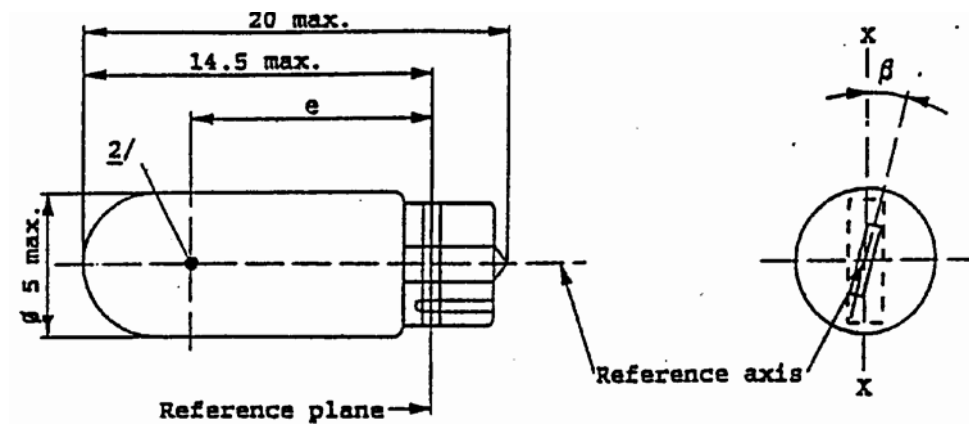

DIMENSIONS in mm	Filament lamps of normal production			Standard filament lamp
	min.	nom.	max.	
e	10.3	10.8	11.3	10.8 +/- 0.3
Lateral deviation <sup>1/</sup>			1.0	0.5 max.
beta	-15 degrees	0 degrees	+15 degrees	0 degrees +/- 5 degrees
Cap W 2 x 4.6d in accordance with IEC Publ. 61 (sheet 7004-94-2)				
<b>ELECTRICAL AND PHOTOMETRIC CHARACTERISTICS</b>				
Rated values	V		12	12
	W		2.3	2.3
Test voltage	V		13.5	
Objective values	W		2.5 max.	2.5 max. at 13.5V
	Luminous flux lm +/- %		18.6 20	
Reference luminous flux : 18.6lm at approx. 13.5V				

- 1/ Maximum lateral deviation of filament centre from two mutually perpendicular planes both containing the reference axis and one containing axis X-X.  
 2/ See paragraph 3.5.3.

**CATEGORY H8**

Sheet H8/1

The drawings are intended only to illustrate the essential dimensions of the filament lamp.

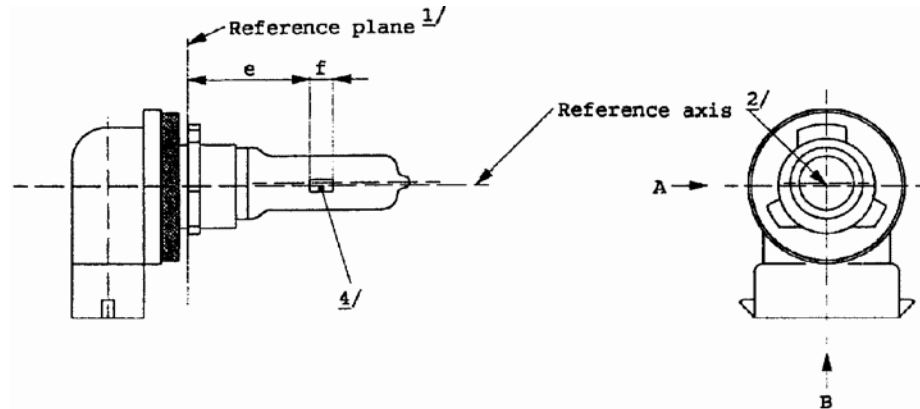

Figure 1- Main drawing

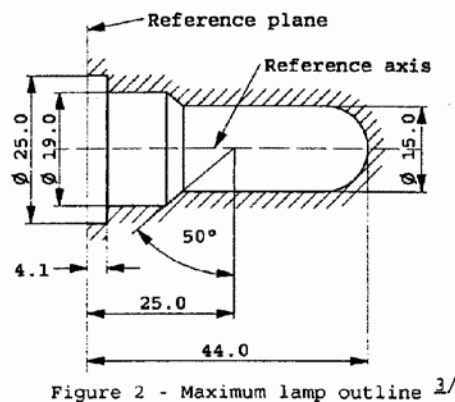

Figure 2  
Maximum lamp outline <sup>3/</sup>

- 1/ The reference plane is the plane formed by the underside of the beveled lead-in flange of the cap.
- 2/ The reference axis is perpendicular to the reference plane and passing through the centre of the 19mm cap diameter.
- 3/ Glass bulb and supports shall not exceed the envelope as indicated in figure 2. The envelope is concentric to the reference axis.
- 4/ The bulb shall be colourless or yellow.
- 5/ Notes concerning the filament diameter.
  - No actual diameter restrictions apply but the objective for future developments is to have  $d_{max.} = 1.2\text{mm}$
  - For the same manufacturer, the design diameter of standard (etalon) filament lamp and filament lamp of normal production shall be the same.

**CATEGORY H8**

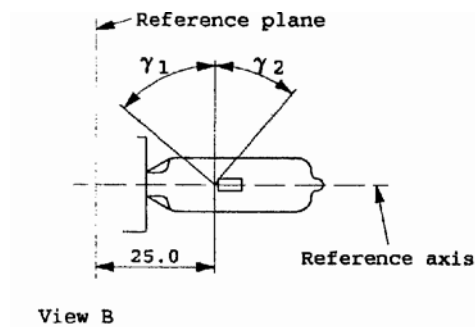

Figure 3- Distortion free area<sup>5/</sup>

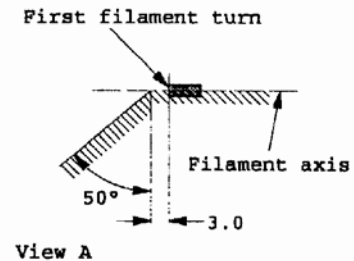

Figure 4- Metal free zone<sup>6/</sup>

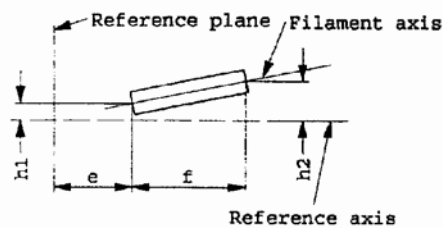

Figure 5- Offset of filament axis<sup>7/</sup>  
(for standard filament lamps only)

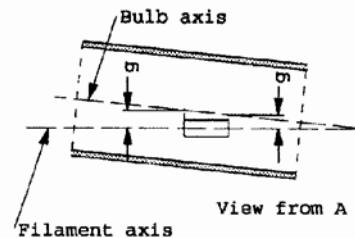

Figure 6- Bulb eccentricity<sup>8/</sup>

6/ Glass bulb shall be optically distortion free within the angles  $\gamma_1$  and  $\gamma_2$ . This requirement applies to the whole bulb circumference within the angles  $\gamma_1$  and  $\gamma_2$ .

7/ The obscuration shall extend at least to angle  $\gamma_3$  and shall extend at least to the cylindrical part of the bulb on the whole bulb top circumference.

8/ The internal design of the lamp shall be such that stray light images and reflections are only located above the filament itself seen from the horizontal direction. (View (1) as indicated in figure 1, sheet H8/1).

No metal parts other than filament turns shall be located in the shaded area as seen in figure 4.

9/ The offset of the filament with respect to the reference axis is measured only in viewing directions (1) and (2) as shown in figure 1 on sheet H 8/1.

The points to be measured are those where the projection of the outside of the end turns nearest to or furthest from the reference plane crosses the filament axis.

10/ Offset of filament in relation to bulb axis measured in two planes parallel to the reference plane where the projection of the outside of the end turns nearest to or furthest from the reference plane crosses the filament axis.



**CATEGORY H8**

Sheet H8/3

DIMENSIONS in mm		Filament lamps of normal production	Standard filament lamp
		12V	12V
e <sup>11/</sup>		25.0 <sup>12/</sup>	25.0 +/- 0.1
f <sup>11/</sup>		3.7	3.7 +/- 0.1
G		0.5 min.	u.c.
h1		0 <sup>12/</sup>	0 +/- 0.1
h2		0 <sup>12/</sup>	0 +/- 0.15
gamma 1		50 degrees min.	50 degrees min
gamma 2		40 degrees min.	40 degrees min
gamma 3		30 degrees min.	30 degrees min
Cap PGJ 19 in accordance with IEC Publication 61 (sheet 7004-110-1)			
<b>ELECTRICAL AND PHOTOMETRIC CHARACTERISTICS</b>			
Rated values	V	12	12
	W	35	35
Test voltage	V	13.2	
Objective values	W	max	max
		43	43 at 13.2V
	Luminous	800	
	flux 1m +/- %	15	
Reference luminous flux for headlamp testing: 600lm at approx. 12V			

<sup>11/</sup>The end of the filaments are defined as the points where, when the viewing direction is direction (1) as shown in figure 1, sheet H8/1, the projection of the outside of the end turns crosses the filament axis.

<sup>12/</sup>To be checked by means of a "Box System". Sheet H8/4.

**CATEGORY H8**

Sheet H8/4

**Screen projection requirements**

This test is used to determine, by checking whether the filament is correctly positioned relative to the reference axis and the reference plane, whether a filament lamp complies with the requirements.

Dimensions in mm

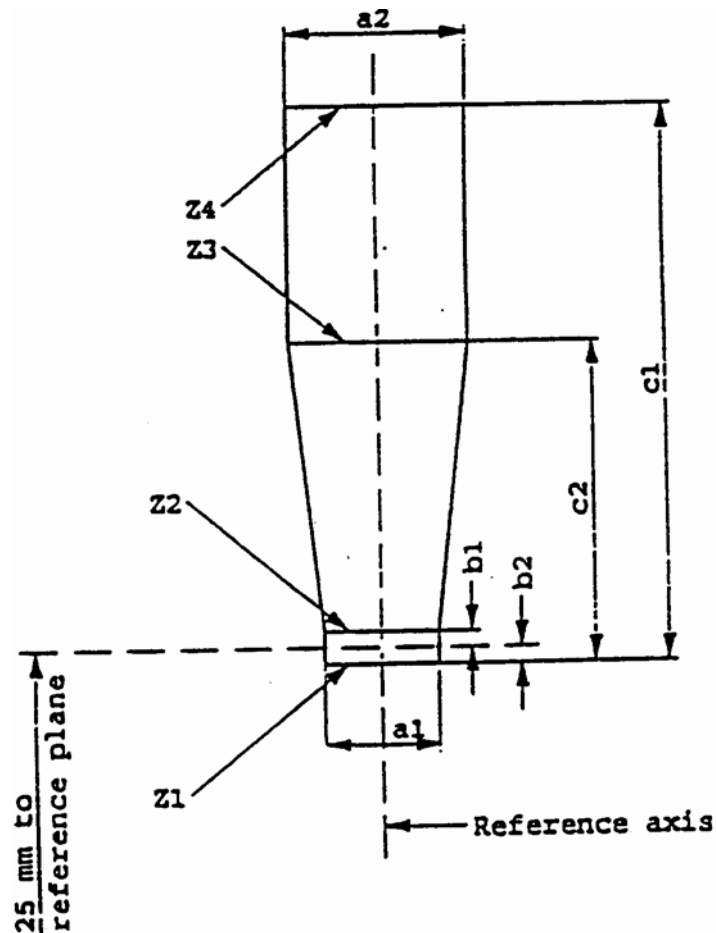

	a1	a2	B1	b2	c1	c2
12V	d+0.50	d+0.70	0.25		4.6	3.5

d = diameter of filament

The ends of the filaments as defined on sheet H8/3, note 11/, shall lie between lines Z1 and Z2 and between lines Z3 and Z4.

The filament position is checked solely in directions (1) and (2) as shown on sheet H8/1, figure 1.

The filament shall lie entirely within the limits shown.

**CATEGORY W16W**

Sheet W16W/1

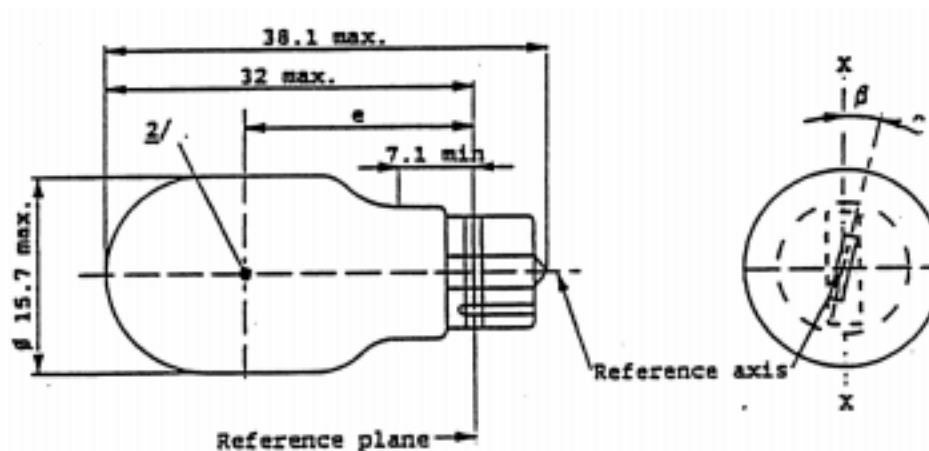

DIMENSIONS in mm	Filament lamps of normal production			Standard filament lamp
	min.	Nom.	max.	
e	18.3	20.6	22.9	20.6 +/- 0.3
Lateral deviation <sup>1/</sup>			1.0	0.5 max.
beta	-15 degrees	0 degrees	+15 degrees	0 degrees +/- 5 degrees
Cap W 2.1 x 9.5d in accordance with IEC Publ. 61 (sheet 7004-91-3)				
<b>ELECTRICAL AND PHOTOMETRIC CHARACTERISTICS</b>				
Rated values	V	12		12
	W	16		16
Test voltage	V	13.5		
Objective values	W +/--%	19.4		19.4 at 13.5V
		10		10
	Luminous flux lm +/--%	310		
		20		
Reference luminous flux : 310lm at approx. 13.5V				

1/ Maximum lateral deviation of filament centre from two mutually perpendicular planes both containing the reference axis and one containing axis x-x.

2/ See paragraph 3.5.3.

**CATEGORY HIR1/1**

Sheet HIR1/1

The drawings are only to illustrate the essential dimensions of the filament lamp.

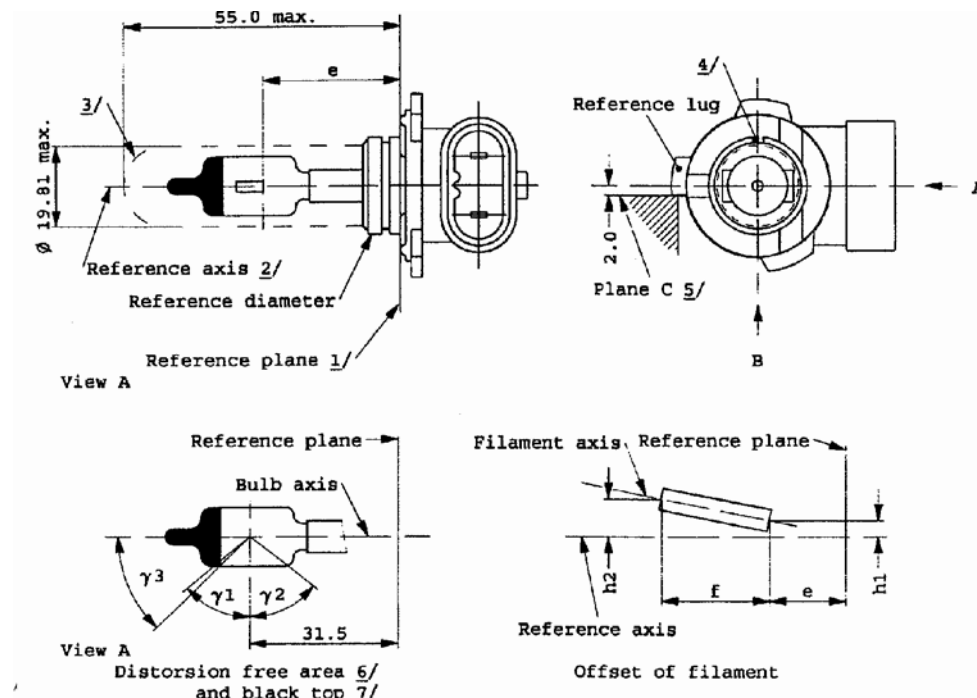

- 1/ The reference plane is the plane defined by the three supporting bosses on the cap flange.
- 2/ The reference axis is perpendicular to the reference plane and passes through the center of the reference diameter of the cap.
- 3/ Glass bulb and supports shall not exceed the envelope. The envelope is concentric to the reference axis.
- 4/ The keyway is mandatory.
- 5/ The filament lamp shall be rotated in the measuring holder until the reference lug contacts plane C of the holder.
- 6/ Glass bulb periphery shall be optically distortion-free axially within the angles  $\gamma_1$  and  $\gamma_2$ . This requirement applies to the whole bulb circumference within the angles  $\gamma_1$  and  $\gamma_2$ .

**CATEGORY HIR1/1**

**Sheet HIR1/2**

Dimensions in mm <sup>11/</sup>		Tolerances	
		Filament lamps of normal production	Standard filament lamp
e <sup>8/</sup> <sup>10/</sup>	29	9/	+/- 0.16
f <sup>8/</sup> <sup>10/</sup>	5.1	9/	+/- 0.16
g <sup>8/</sup>	0	+ 0.7 - 0.0	+ 0.4 - 0.0
h1, h2	0	9/	
d	1.6 max	-	-
gamma1	50 degrees min.	-	-
gamma2	50 degrees min.	-	-
Cap PX 20d in accordance with IEC Publ. 61 (sheet 7004-...-..)			
<b>ELECTRICAL AND PHOTOMETRIC CHARACTERISTICS</b>			
Rated values	V	12	12
	W	65	65
Test voltage	V	13.2	13.2
Objective values	W	73 max.	73 max.
	Luminous flux lm +/- %	2,500	
		15	
Reference luminous flux for headlamp testing: 1,840lm at approx. 12V.			

<sup>11/</sup>Dimensions shall be checked with O-ring mounted.

<sup>8/</sup>The viewing direction is direction B as shown in the figure on sheet HIR1/1.

<sup>10/</sup>The ends of the filament are defined as the points where, when the viewing direction as defined in note 8/ above, the projection of the outside of the end turns crosses the filament axis.

<sup>9/</sup>To be checked by means of a "box-system ". Sheet HIR1/3.

<sup>7/</sup>The eccentricity is measured only in viewing directions A and B as shown in the figure on sheet HIR1/1. The points to be measured are those whether the projection of the outside of the end turns nearest to or furthest from the reference plane crosses the filament axis.

**CATEGORY HIR1/1**

Sheet HIR1/3

**Screen projection requirements**

This test is used to determine, by checking whether the filament is correctly positioned relative to the reference axis and the reference plane, whether a lamp complies with the requirements.

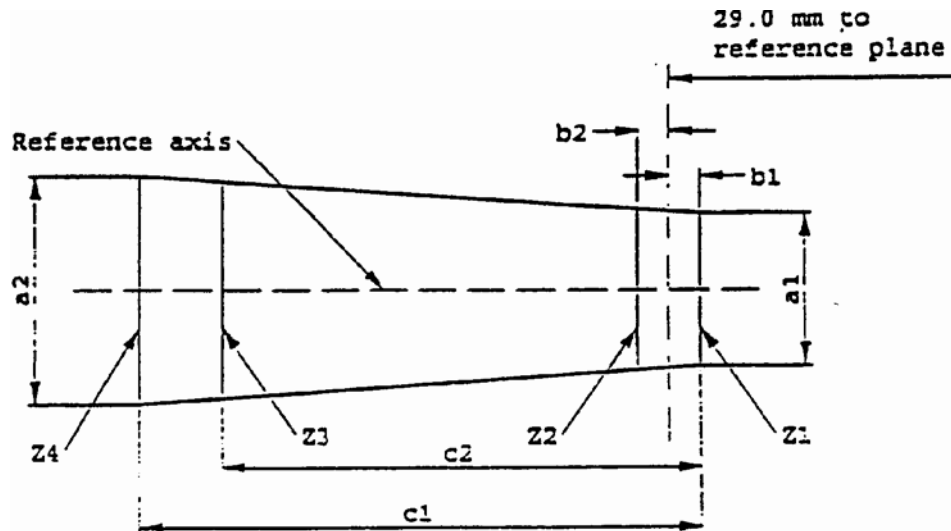

	a1	a2	b1	b2	c1	c2
12V	d +0.4	d +0.8	0.35		6.1	5.2

d = diameter of filament

The filament position is checked solely in directions A and B as shown on sheet HIR1/1.

The beginning of the filament as defined on sheet HIR1/2, note <sup>10/</sup> shall lie between lines Z1 and Z2 and between lines Z3 and Z4.

**CATEGORY PY27/7W**

Sheet PY27/7W/1

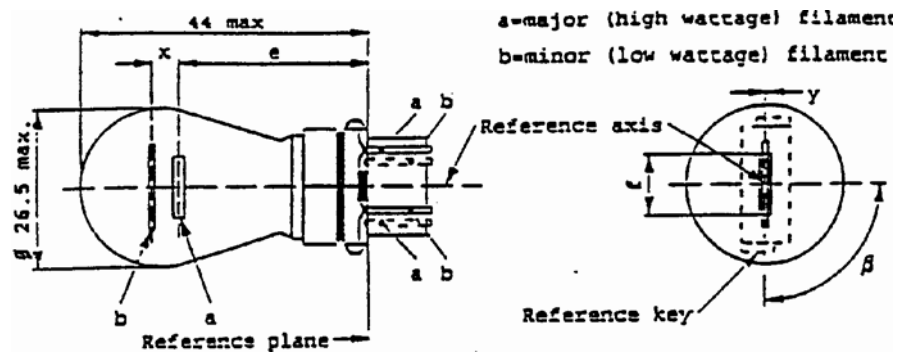

DIMENSIONS in mm	Filament lamps of normal production			Standard filament lamp		
	min.	nom.	max.			
e		27.9 <sup>3/</sup>		27.9 +/- 0.3		
f			9.9	9.9 +0 - 2		
Lateral deviation <sup>2/</sup>			3/	0.0 +/- 0.4		
x <sup>4/</sup>		5.1 <sup>3/</sup>		5.1 +/- 0.5		
y <sup>4/</sup>		0.0 <sup>3/</sup>		0.0 +/- 0.5		
beta	75 degrees <sup>3/</sup>	90 degrees	105 degrees <sup>3/</sup>	90 degrees +/- 5 degrees		
Cap WX 2.5x16q in accordance with IEC Publ. 61 (sheet 7004- -1)						
<b>ELECTRICAL AND PHOTOMETRIC CHARACTERISTICS</b>						
Rated values	V	12		12		
	W	27	7	27	7	
Test voltage	V	13.5				
Objective values	Watts	W	29.2	7.7	29.2	7.7
		at 13.5V				
	Luminous Flux	+/- %	10		10	
		lm	280	21		
	+/- %	15				
Reference luminous flux: Amber bulb: 280 and 21lm <div style="text-align: center;">at approx. 13.5V</div> Clear bulb: 475 and 36lm						

<sup>1/</sup>The reference axis is defined with respect to the reference keys and is perpendicular to the reference plane.  
<sup>2/</sup>Maximum lateral deviation of major filament centre from two mutually perpendicular planes both containing the reference axis and one containing axis through reference keys.  
<sup>3/</sup>To be checked by means of a box system, sheets PY27/7W/2 and 3.

---

<sup>4</sup>"x" and "y" denote the offset of the axis of the minor (low wattage) filament with respect to the axis of the major (high wattage) filament.



---

**CATEGORY PY27/7W**

**Sheet PY27/7W/2**

Screen projection requirements

This test is used to determine, by checking whether:

- (a) the major filament is correctly positioned relative to the reference axis and reference plane and has an axis perpendicular, within +/- 15 degrees , to the plane through the centres of the keys and the reference axis; and
- (b) the minor filament is correctly positioned relative to the major filament, whether a filament lamp complies with the requirements.

Test procedure and requirements.

Test procedure and requirements.

1. The filament lamp is placed in a holder capable of being rotated about its axis and having either a calibrated scale or fixed stops corresponding to the angular displacement tolerance limits. The holder is then so rotated that an end view of the major filament is seen on the screen on to which the image of the filament is projected. The end view of that filament shall be obtained within the angular displacement tolerance limits.

2. **Side elevation**

The filament lamp placed with the cap down, the reference axis vertical, the reference key to the right and the major filament seen end-on:

- 2.1. the projection of the major filament shall lie entirely within a rectangle of height "a" and width "b", having its centre at the theoretical position of the centre of the filament;
- 2.2. the projection of the minor filament shall lie entirely within a rectangle of width "c" and height "d" having its centre at a distance "u" above the theoretical position of the centre of the major filament.

3. **Front elevation**

The filament lamp placed with the cap down and the reference axis vertical, the filament lamp being viewed in a direction at right angles to the axis of the major filament:

- 3.1. the projection of the major filament shall lie entirely within a rectangle of height "a" and width "h", centred on the theoretical position of the centre of the filament;
- 3.2. the centre of the major filament shall not be offset by more than distance "k" from the reference axis;
- 3.3. the centre of the minor filament shall not be offset from the reference axis by more than +/- 2mm (+/- 0.4mm for standard lamps).

**CATEGORY PY27/7W**

Sheet PY27/7W/3

Side elevation

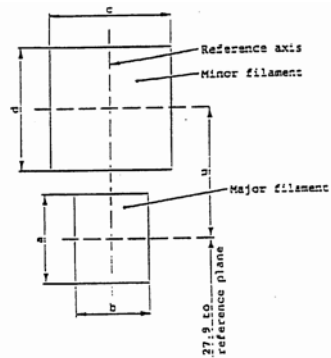

Reference	a	b	c	d	u
Dimensions	3.5	3.0	4.8		5.1

Front elevation

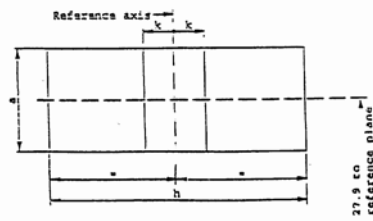

Reference	a	h	k
Dimensions	3.5	11.9	1.0

**CATEGORY HIR2**

Sheet HIR2/1

The drawings are only to illustrate the essential dimensions of the filament lamp  
 Dimensions in mm

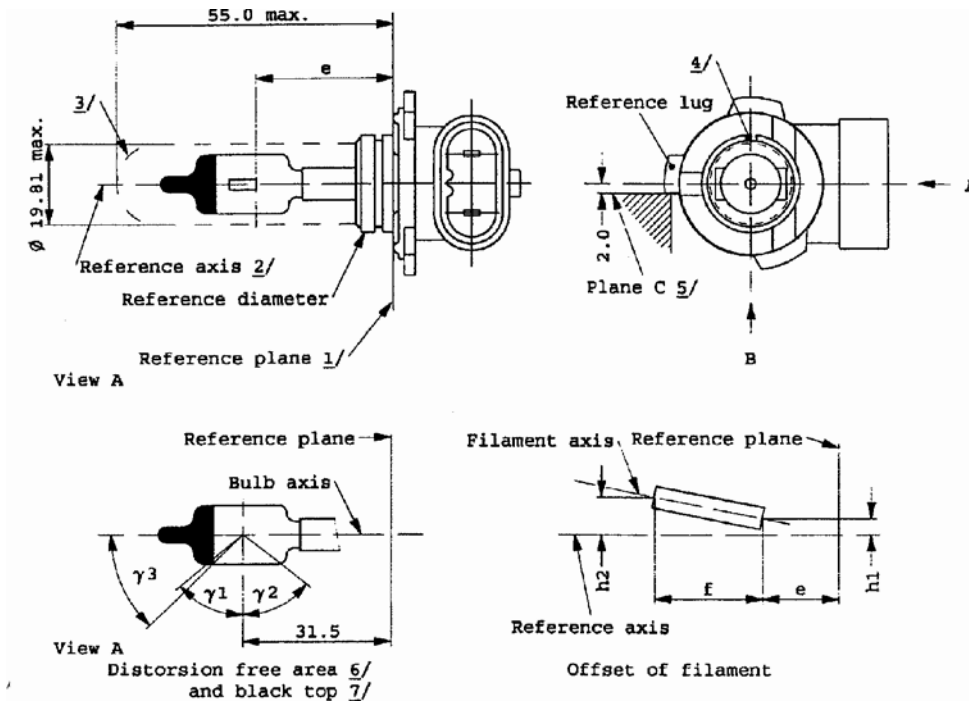

- 1/ The reference plane is the plane defined by the three meeting points of the cap- holder fit.
- 2/ The reference axis is perpendicular to the reference plane and passes through the center of the reference diameter of the cap.
- 3/ Glass bulb and supports shall not exceed the envelope. The envelope is concentric to the reference axis.
- 4/ The keyway is mandatory.
- 5/ The filament lamp shall be rotated in the measuring holder until the reference lug contacts plane C of the holder.
- 6/ Glass bulb periphery shall be optically distortion-free axially within the angles  $\gamma_1$  and  $\gamma_2$ . This requirement applies to the whole bulb circumference within the angles  $\gamma_1$  and  $\gamma_2$ .

**CATEGORY HIR2**

Sheet HIR2/2

Dimensions in mm 11/		Tolerances	
		Filament lamps of normal production	Standard filament lamp
e <sup>8/</sup> 10	28.9	9/	+/- 0.16
f <sup>8/</sup> 10	5.3	9/	+/- 0.16
g <sup>8/</sup>	0	+ 0.7 - 0.0	+ 0.4 - 0.0
h1, h2	0	9/	+/- 0.15
d	1.6 max	-	-
gamma <sub>1</sub>	50 degrees min.	-	-
gamma <sub>2</sub>	50 degrees min.	-	-
Cap PX 22d in accordance with IEC Pub1. 61 (sheet 7004-...)			
<b>ELECTRICAL AND PHOTOMETRIC CHARACTERISTICS</b>			
Rated values	V	12	12
	W	55	55
Test voltage	V	13.2	13.2
Objective values	W	63 max.	63 max.
	Luminous flux 1m +/- %	1,875	
		15	
Reference luminous flux for headlamp testing: 1,355 1m at approx. 12V			

7/ The eccentricity is measured only in viewing directions A and B as shown in the figure on sheet HIR2/1. The points to be measured are those where the projection of the outside of the end turns nearest to or furthest from the reference plane crosses the filament axis.

8/ The viewing direction is direction B as shown in the figure on sheet HIR2/1.

9/ To be checked by means of a "box-system". Sheet HIR2/3.

10/ The ends of the filament are defined as the points where, when the viewing direction as defined in note<sup>8/</sup> above, the projection of the outside of the end turns crosses the filament axis.

11/Dimensions shall be checked with O-ring removed.

**CATEGORY HIR2**

Sheet HIR2/3

Screen projection requirements

This test is used to determine, by checking whether the filament is correctly positioned relative to the reference axis and the reference plane, whether a lamp complies with the requirements.

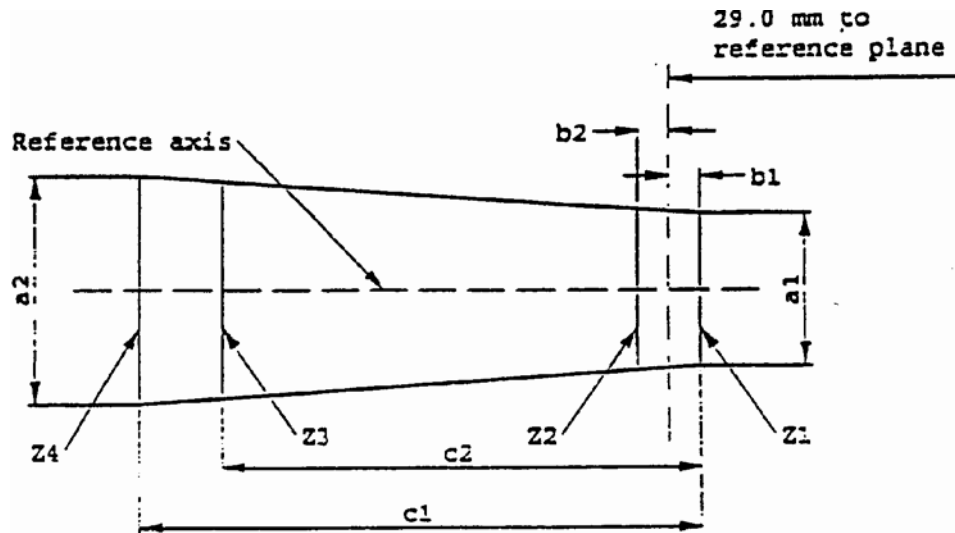

	a1	a2	b1	b2	c1	c2
12V	$d + 0.4$	$d + 0.8$	0.35		6.6	5.7

d = diameter of filament

The filament position is checked solely in directions A and B as shown on sheet HIR2/1.

The beginning of the filament as defined on sheet HIR2/2, note <sup>10/</sup> shall lie between lines Z1 and Z2 and between lines Z3 and Z4.

**CATEGORY H9**

Sheet H9/1

The drawings are intended only to illustrate the essential dimensions of the filament lamp.

Dimensions in mm

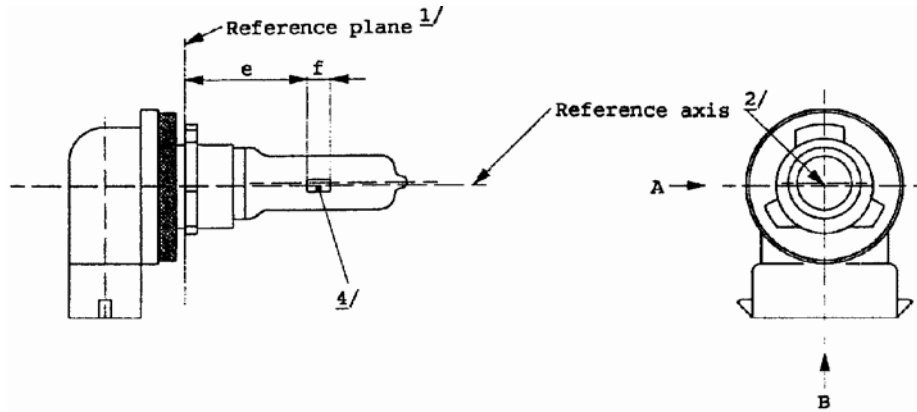

Figure 1- Main drawing

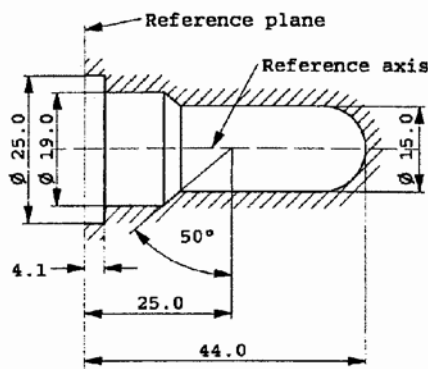

Figure 2 - Maximum lamp outline 1/

1/ The reference plane is the plane formed by the underside of the beveled lead-in flange of the cap.

2/ The reference axis is perpendicular to the reference plane and passing through the centre of the 19mm cap diameter.

3/ Glass bulb and supports shall not exceed the envelope as indicated in Figure 2. The envelope is concentric to the reference axis.

4/ Notes concerning the filament diameter.

- No actual diameter restrictions apply but the objective for future developments is to have  $d_{max.} = 1.4\text{mm}$  -  
For the same manufacturer, the design diameter of standard (etalon) filament lamp and filament lamp of normal production shall be the same.

**CATEGORY H9**

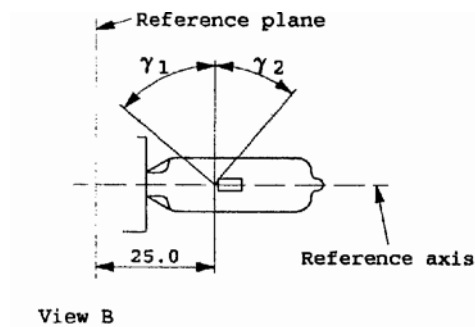

Figure 3- Distortion free area<sup>5/</sup>

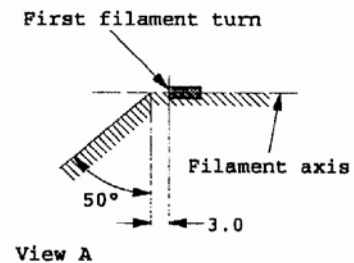

Figure 4- Metal free zone<sup>6/</sup>

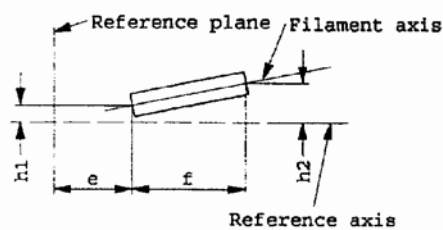

Figure 5- Offset of filament axis<sup>7/</sup>  
 (for standard filament lamps only)

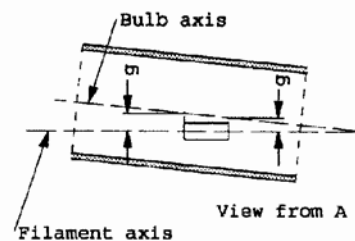

Figure 6- Bulb eccentricity<sup>8/</sup>

- 5/ Glass bulb shall be optically distortion free within the angles  $\gamma_1$  and  $\gamma_2$ . This requirement applies to the whole bulb circumference within the angles  $\gamma_1$  and  $\gamma_2$ .
- 6/ The internal design of the lamp shall be such that stray light images and reflections are only located above the filament itself seen from the horizontal direction. (View A as indicated in Figure 1, sheet H9/1). No metal parts other than filament turns shall be located in the shaded area as seen in Figure 4.
- 7/ The offset of the filament with respect to the reference axis is measured only in viewing directions A and B as shown in Figure 1 on sheet H9/1. The points to be measured are those where the projection of the outside of the end turns nearest to or furthest from the reference plane crosses the filament axis.
- 8/ Offset of bulb with respect to filament axis measured in two planes parallel to the reference plane where the projection of the outside of the end turns nearest to or furthest from the reference plane crosses the filament axis.

**CATEGORY H9**

Sheet H9/3

Dimensions in mm <sup>13/</sup>		Tolerances	
		Filament lamps of normal production	Standard filament lamp
e <sup>9/</sup>	25	11	+/- 0.10
f <sup>9/</sup> <sup>10/</sup> 10	4.8	11	+/- 0.10
g <sup>9/</sup>	0.70	+/- 0.5	+/- 0.30
h1	0	11	+/- 0.10 <sup>12/</sup>
h2	0	12	+/- 0.15 <sup>12/</sup>
gamma <sub>1</sub>	50 degees min.	-	-
gamma <sub>2</sub>	40 degees min.	-	-
Cap PGJ19-5 in accordance with IEC 61 (sheet 7004-110-1)			
ELECTRICAL AND PHOTOMETRIC CHARACTERISTICS			
Rated values	V	12	12
	W	65	65
Test voltage	V	13.2	13.2
Objective values	W	73 max.	73 max.
	Luminous flux 1m +/- %	2,100	
		10	
Reference luminous flux for headlamp testing: 1,500 1m at approx. 12V			

<sup>9/</sup> The viewing direction is direction A as shown in Figure 1 on sheet H9/1.  
<sup>10/</sup> The ends of the filament are defined as the points where, when the viewing direction as defined in note <sup>9/</sup> above, the projection of the outside of the end turns crosses the filament axis.

<sup>11/</sup> To be checked by means of a " box-system". Sheet H9/4.

<sup>12/</sup> The eccentricity is measured only in viewing directions A and B as shown in Figure 1 on sheet H9/1. The points to be measured are those where the projection of the outside of the end turns nearest to or furthest from the reference plane crosses the filament axis.



**CATEGORY H9**

Sheet H9/4

Screen projection requirements

This test is used to determine, by checking whether the filament is correctly positioned relative to the reference axis and the reference plane, whether a lamp complies with the requirements.

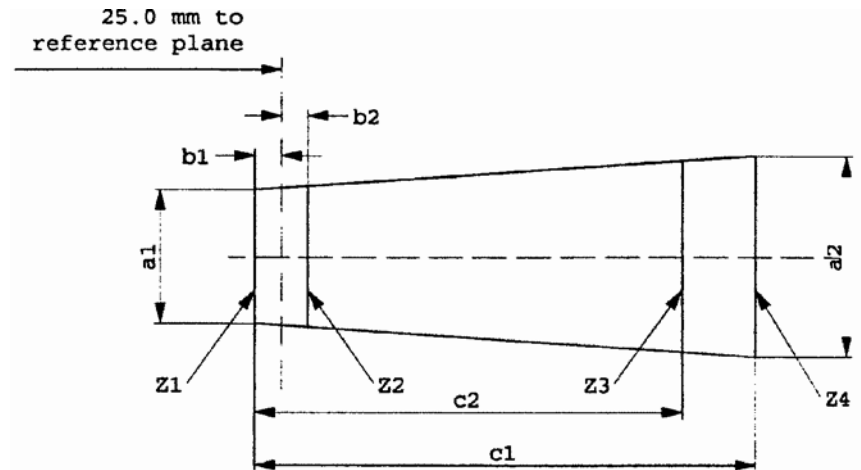

	a1	a2	b1	b2	c1	c2
12V	$d + 0.4$	$d + 0.7$	0.25		5.7	4.6

d = diameter of filament

The filament position is checked solely in directions A and B as shown on sheet H9/1.

The ends of the filament as defined on sheet H9/3, note <sup>10/</sup> shall lie between lines Z1 and Z2 and between lines Z3 and Z4.

**CATEGORY H10**

Sheet H10/1

The drawings are only to illustrate the essential dimensions of the filament lamp

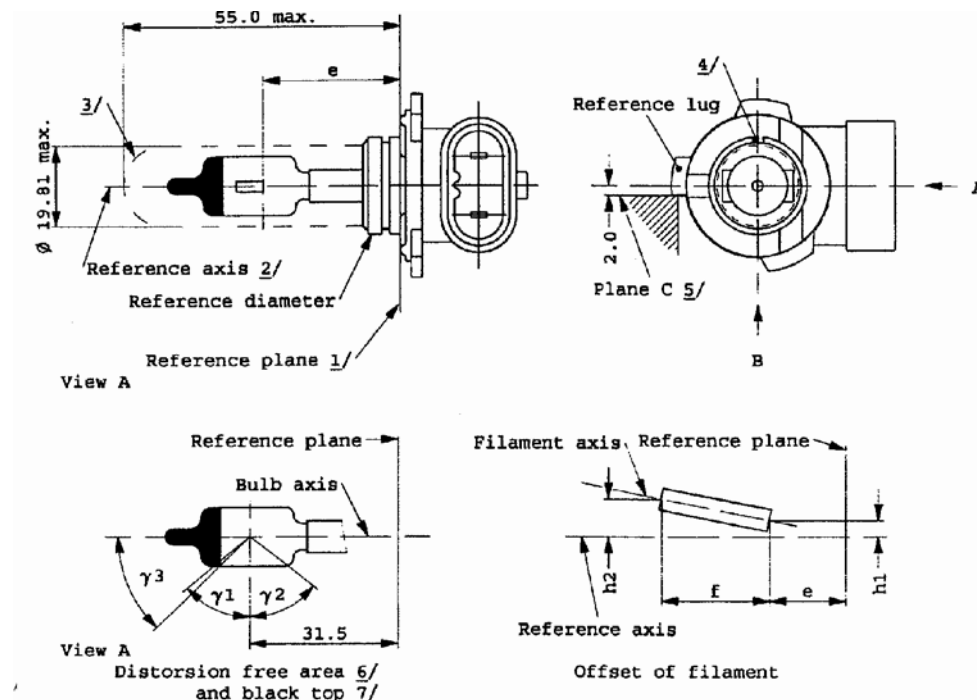

- 1/ The reference plane is the plane defined by the meeting points of the cap-holder fit.
- 2/ The reference axis is perpendicular to the reference plane and concentric with the reference diameter of the cap.
- 3/ Glass bulb and supports shall not exceed the envelope and shall not interfere with insertion past the lamp key. The envelope is concentric to the reference axis.
- 4/ The keyway is mandatory.
- 5/ The filament lamp shall be rotated in the measuring holder until the reference lug contacts plane C of the holder.
- 6/ Glass bulb periphery shall be optically distortion-free axially within the angles  $\gamma_1$  and  $\gamma_2$ . This requirement applies to the whole bulb circumference within the angles  $\gamma_1$  and  $\gamma_2$ .
- 7/ The obscuration shall extend to at least angle  $\gamma_3$  and shall be at least as far as the undistorted part of the bulb defined by angle  $\gamma_1$ .

**CATEGORY H10**

Sheet H10/2

Dimensions in mm <sup>8/</sup>		Tolerances	
		Filament lamps of normal production	Standard filament lamp
e <sup>9/</sup> <sup>10/</sup>	28.9	11	+/- 0.16
f <sup>9/</sup> <sup>10/</sup>	5.2	11	+/- 0.16
h1, h2	0	11	+/- 0.15 <sup>12/</sup>
gamma <sub>1</sub>	50 degrees min.		
gamma <sub>2</sub>	52 degrees min.		
gamma <sub>3</sub>	45 degrees	+/- 5 degrees	+/- 5 degrees
Cap PY20d in accordance with IEC 61 (sheet 7004-...)			
<b>ELECTRICAL AND PHOTOMETRIC CHARACTERISTICS</b>			
Rated values	Volts	12	12
	Watts	42	42
Test voltage	Volts	13.2	13.2
Objective values	Watts	50 max.	50 max.
	Luminous flux 1m	850	
	+/- %	15	
Reference luminous flux: 600 1m at approx. 12V			

- 8/ Dimensions shall be checked with O-ring removed.
- 9/ The viewing direction is direction <sup>\*/</sup> B as shown in the figure on sheet H10/1.
- 10/ The ends of the filament are defined as the points where, when the viewing direction <sup>\*/</sup> as defined in note <sup>9/</sup> above, the projection of the outside of the end turns crosses the filament axis.
- 11/ To be checked by means of a " box-system". Sheet H10/3. <sup>\*/</sup>
- 12/ The eccentricity is measured only in viewing directions <sup>\*/</sup> A and B as shown in the figure on sheet H10/1. The points to be measured are those where the projection of the outside of the end turns nearest to or furthest from the reference plane crosses the filament axis.

\* Manufacturers may choose another set of perpendicular viewing directions. The viewing directions specified by the manufacturer are to be used by the testing laboratory when checking filament dimensions and position.

**CATEGORY H10**

Sheet H10/3

Screen projection requirements

This test is used to determine, by checking whether the filament is correctly positioned relative to the reference axis and the reference plane, whether a filament lamp complies with the requirements.

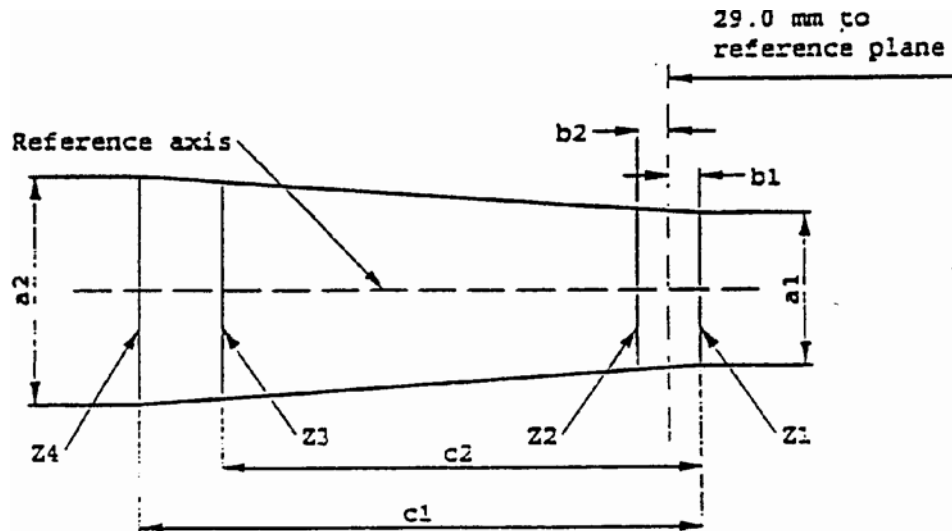

	a1	a2	b1	b2	c1	c2
12 V	1.4 d	1.8 d	0.25		6.1	4.9

d = diameter of filament

The filament position is checked solely in directions A and B as shown on sheet H10/1.

The ends of the filament as defined on sheet H10/2, note <sup>10/</sup> shall lie between lines Z1 and Z2 and between lines Z3 and Z4.

**Annex 2**

**COMMUNICATION**

**(Maximum format: A4 (210 x 297 mm))**

Issued by: .....  
Name of administration: .....  
.....  
.....



Concerning: <sup>2/</sup>APPROVAL GRANTED  
APPROVAL EXTENDED  
APPROVAL REFUSED  
APPROVAL WITHDRAWN  
PRODUCTION DEFINITELY DISCONTINUED  
of a type of filament lamp pursuant to Regulation No. 37 Approval No. ....  
Extension No. .... 1.

- Trade name or mark of the device:.....
2. Manufacturer's name for the type of device:.....
3. Manufacturer's name and address:.....
4. If applicable, name and address of the manufacturer's representative:  
.....
5. Submitted for approval on:.....
6. Technical service responsible for conducting approval tests:.....
7. Date of report issued by that service:.....
8. Number of report issued by that service:.....
9. Concise description:.....  
Category of filament lamp:.....  
Rated voltage:.....  
Colour of light emitted: White/selective yellow/amber <sup>2/</sup>
10. Position of the approval mark:.....
11. Reason(s) for extension (if applicable):.....
12. Approval granted/refused/extended/withdrawn: <sup>2/</sup>
13. Place:.....
14. Date:.....
15. Signature:.....
16. The following documents, bearing the approval number shown above, are available on request:

<sup>1/</sup>Distinguishing number of the country which has granted/extended/refused/withdrawn approval (see approval provisions in the Regulation)

<sup>2/</sup> Strike out what does not apply.

/

Annex 3

EXAMPLE OF THE ARRANGEMENT OF THE APPROVAL MARK

(See paragraph 2.4.3.)

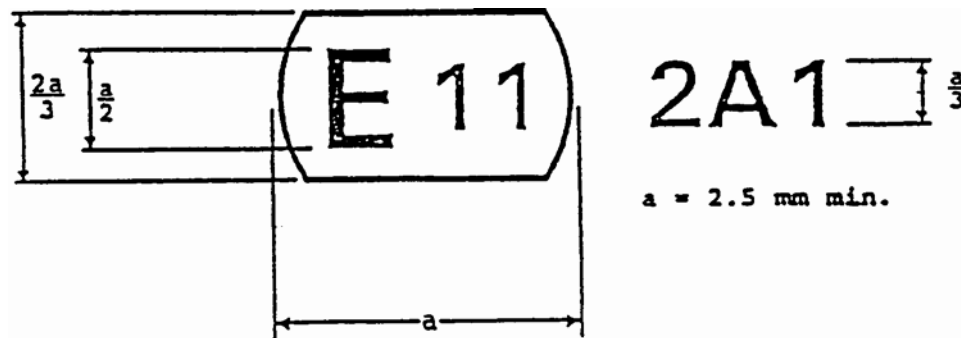

The above approval mark affixed to a filament lamp indicates that the filament lamp has been approved in the United Kingdom (E11) under approval code A1. The first character of the approval code indicates that the approval was granted in accordance with the requirements of Regulation No. 37 as amended by the 02 and 03<sup>\*/</sup> series of amendments.

<sup>\*/</sup>Not requiring changes in the approval number.

**Annex 4**

**LUMINOUS CENTRE AND SHAPES OF LAMP FILAMENTS**

Save as possibly otherwise indicated on the lamp data sheets, this standard is applicable to the determination of the luminous centre of different filament shapes.

The position of the luminous centre depends upon the filament shape.

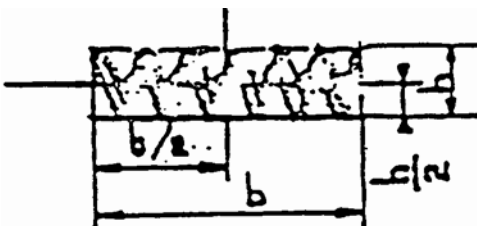
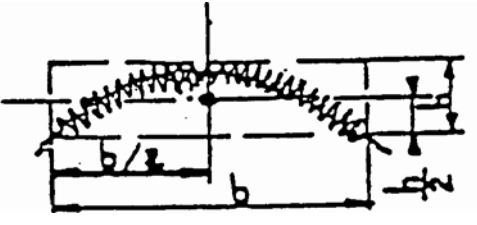
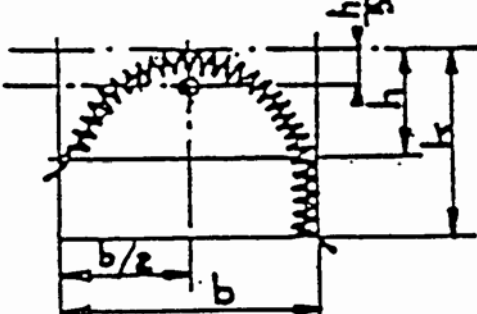
No.	Filament shapes	Observations
1		<p>With <math>b &gt; 1.5h</math>, the deviation of the filament axis with respect to a plane normal to the reference axis shall not exceed 15 degrees .</p>
2		<p>Only applicable to filaments which can be inscribed in a rectangle of <math>b &gt; 3h</math>.</p>
3		<p>Applicable to filaments which can be inscribed in a rectangle of <math>b &lt; 3h</math>, whereby however <math>k &lt; 2h</math>.</p>

The side lines of the circumscribed rectangles in Nos. 2 and 3 are parallel and perpendicular, respectively, to the reference axis.

The luminous centre is the point of intersection of the dash-dot lines.

---

**Annex 5**

**CHECKING THE COLOUR AND TRANSMISSION OF SELECTIVE-YELLOW BULBS AND  
OUTER BULBS AND AMBER BULBS**

**1. General specifications**

- 1.1. The manufacturer shall send to the test laboratory five finished filament lamps with coloured bulb or coloured outer bulb. Filament lamps with coloured outer bulb shall be handled as filament lamps with coloured bulb.
- 1.2. All the tests shall be made at an ambient temperature of 23 degrees C +/- 5 degrees C.
- 1.3. The tests shall be made at test voltage.
- 1.4. Before starting each test the stabilisation of the temperature of the filament lamp shall be obtained by operating at test voltage for 10 minutes.

**2. Colour**

- 2.1. The colour should be so homogeneous that at visual inspection no essential differences are perceptible.
- 2.2. Measuring the colour the reference axis of the filament lamp shall be vertical with the cap down. The measuring direction shall be perpendicular to the reference axis and to the axis of the filament too. In case of doubt with regard to homogeneous colour the sample shall be measured in several directions and all shall comply.
- 2.3. The test shall be made with a measuring system which shows the CIE chromaticity co-ordinates of the received light with an accuracy of +/- 0.002.
- 2.4. In the case of measuring the colour of filament lamps with selective-yellow bulb the measurement shall be made by integrating within a cone having an apex angle of 60 degrees perpendicular to the reference axis of the filament lamp with the origin in the centre of the main beam filament.
- 2.5. In the case of measuring the colour of filament lamps with amber bulb the measurement shall be made by integrating within a cone having an apex angle of 4 degrees perpendicular to the reference axis of the filament lamp with the origin in the centre of the filament.

**3. Transmission**

- 3.1. The transmission shall be such that the emitted luminous flux of the filament lamp lies within the tolerance values specified for the relevant filament lamp in this Regulation.



---

**Annex 6**

**MINIMUM REQUIREMENTS FOR QUALITY CONTROL PROCEDURES BY THE MANUFACTURER**

**1. GENERAL**

The conformity requirements shall be considered satisfied from a photometric, geometrical, visual and electrical standpoint if the specified tolerances for production filament lamps in the relevant data sheet of annex 1 and the relevant data sheet for the caps are met.

**2. MINIMUM REQUIREMENTS FOR VERIFICATION OF CONFORMITY BY THE MANUFACTURER**

For each type of filament lamp the manufacturer or the holder of the approval mark shall carry out tests, in accordance with the provisions of this Regulation, at appropriate intervals.

2.1. Nature of tests

Tests of conformity of these specifications shall cover their photometrical, geometrical and optical characteristics.

2.2. Methods used in tests

2.2.1. Tests shall generally be carried out in accordance with the methods set out in this Regulation.

2.2.2. The application of paragraph 2.2.1. requires regular calibration of test apparatus and its correlation with measurements made by a competent authority.

2.3. Nature of sampling

Samples of filament lamps shall be selected at random from the production of a uniform batch. A uniform batch means a set of filament lamps of the same type, defined according to the production methods of the manufacturer.

2.4. Inspected and recorded characteristics

The filament lamps shall be inspected and test results recorded following the grouping of characteristics as listed in annex 7, table 1.

2.5. Criteria governing acceptability

The manufacturer or the holder of the approval is responsible for carrying out a statistical study of the test results in order to meet the specifications laid down for verification of conformity of products in paragraph 4.1 of this Regulation. Compliance shall be assured if the level of acceptable non-compliance per grouping of characteristics given in table 1 of annex 7 is not exceeded. This means that the number of lamps not complying with the requirement for any grouping of characteristics of any filament lamp type does not exceed the qualifying limits in the relevant table 2, 3 or 4 of annex 7.

Note: Each individual filament lamp requirement shall be considered as a characteristic.

**Annex 7**

**SAMPLING AND COMPLIANCE LEVELS FOR MANUFACTURER TEST RECORDS**

**Table 1 - Characteristics**

Grouping of characteristics	Grouping <sup>*/</sup> of test records between lamp types	Minimum 12 monthly sample per grouping <sup>*/</sup>	Acceptable level of non-compliance per grouping of characteristics (%)
Marking, legibility and durability	All types with the same external dimensions	315	1
Bulb quality	All types with the same bulb	315	1
Colour of the bulb	All coloured bulbs of the same design	315	
External lamp dimensions (excluding cap/base)	All types of the same category	200	1
Dimensions of caps and bases	All types of the same category	200	6.5
Dimensions related to internal elements <sup>**/</sup>	All lamps of one type	200	6.5
Initial readings, watts and lumens <sup>**/</sup>	All lamps of one type	200	1

<sup>\*/</sup> The assessment shall in general cover series production filament lamps from individual factories. A manufacturer may group together records concerning the same type from several factories, provided these operate under the same quality system and quality management.

<sup>\*\*/</sup> In case a filament lamp has more than one inner element (filament, shield) the grouping of characteristics (dimensions, watts, lumens) applies to each element separately.

Qualifying limits for acceptance based on different numbers of test results for each grouping of characteristics are listed in table 2 as maximum number of non-compliances. The limits are based on an acceptable level of 1% of non-compliances, assuming and acceptance probability of at least 0.95.

**Table 2**

Number of test results of each characteristic			Qualifying limits for acceptance
	-	200	5
201	-	260	6
261	-	315	7
316	-	370	8
371	-	435	9
436	-	500	10
501	-	570	11
571	-	645	12
646	-	720	13
721	-	800	14
801	-	860	15
861	-	920	16
921	-	990	17
991	-		18
	-	1,060	19
1,061	-	1,125	20
1,126	-	1,190	21
1,191		1,249	

Qualifying limits for acceptance based on different number of test results for each grouping of characteristics are listed in table 3 given as maximum number of non-compliances. The limits are based on and acceptable level of 6.5% for non-compliances, assuming an acceptable probability of at least 0.95.

**Table 3**

Number of lamps in records	Qualifying limit	Number of lamps in records	Qualifying limit	Number of lamps in records	Qualifying limit
- 200	21	609 - 621	52	1,030 - 1,043	83
201 - 213	22	622 - 635	53	1,044 - 1,056	84
214 - 227	23	636 - 648	54	1,057 - 1,070	85
228 - 240	24	649 - 662	55	1,071 - 1,084	86
241 - 254	25	663 - 676	56	1,085 - 1,097	87
255 - 268	26	677 - 689	57	1,098 - 1,111	88
269 - 281	27	690 - 703	58	1,112 - 1,124	89
282 - 295	28	704 - 716	59	1,125 - 1,138	90
296 - 308	29	717 - 730	60	1,139 - 1,152	91
309 - 322	30	731 - 744	61	1,153 - 1,165	92
323 - 336	31	745 - 757	62	1,166 - 1,179	93
337 - 349	32	758 - 771	63	1,180 - 1,192	94
350 - 363	33	772 - 784	64	1,193 - 1,206	95
364 - 376	34	785 - 798	65	1,207 - 1,220	96
377 - 390	35		66	1,221 - 1,233	97
391 - 404	36	799 - 812	67	1,234 - 1,249	98
405 - 417	37	813 - 825	68		
418 - 431	38	826 - 839	69		
432 - 444	39	840 - 852	70		
445 - 458	40	853 - 866	71		
459 - 472	41	867 - 880	72		
473 - 485	42	881 - 893	73		
486 - 499	43	894 - 907	74		
500 - 512	44	908 - 920	75		
513 - 526	45	921 - 934	76		
527 - 540	46	935 - 948	77		
541 - 553	47	949 - 961	78		
554 - 567	48	962 - 975	79		
568 - 580	49	976 - 988	80		
581 - 594	50		81		
595 - 608	51	989 - 1,002	82		
		1,003 - 1,016			
		1,017 - 1,029			

Qualifying limits for acceptance based on different numbers of test results for each grouping of characteristics are listed in table 4 given as a percentage of the results, assuming an acceptance probability of at least 0.95.

**Table 4**

Number of test results of each characteristic	Qualifying limits shown as a percentage of results. Acceptable level of 1% of non-compliances.	Qualifying limits shown as a percentage of results. Acceptable level of 6.5% of non-compliances.
1,250	1.68	7.91
2,000	1.52	7.61
4,000	1.37	7.29
6,000	1.30	7.15
8,000	1.26	7.06
10,000	1.23	7.00
20,000	1.16	6.85
40,000	1.12	6.75
80,000	1.09	6.68
100,000	1.08	6.65
1,000,000	1.02	6.55

**Annex 8**

**MINIMUM REQUIREMENTS FOR SPOT CHECKS BY THE ADMINISTRATIVE AUTHORITY**

**1. GENERAL**

The conformity requirements shall be considered satisfied from a photometric, geometrical, visual and electrical standpoint if the specified tolerances for production filament lamps in the relevant data sheet of annex 1 and the relevant data sheet for the caps are met.

2. The conformity of mass-produced filament lamps shall not be contested if the results are in agreement with annex 9 to this Regulation.
3. Conformity shall be contested and the manufacturer requested to make the production meet the requirements if the results are not in agreement with annex 9 to this Regulation.
4. If paragraph 3 of this annex is applied, a further sample of 250 filament lamps, selected at random from a recent production run, shall be taken within two months.

**Annex 9**

**COMPLIANCE APPROVED BY SPOT CHECK**

Compliance approved or disapproved shall be decided according to the values in table 1. For each grouping of characteristics filament lamps shall be either accepted or rejected according to the values in table 1.<sup>\*/</sup>

**Table 1**

Sample	1% <sup>**/</sup>		6.5% <sup>**/</sup>	
	Accept	Reject	Accept	Reject
First sample size: 125	2	5	11	16
If the number of non-conforming units is greater than 2 (11) and less than 5 (16) take a second sample size of 125 and assess the 250	6	7	26	27

<sup>\*\*/</sup> The filament lamps shall be inspected and test results recorded following the grouping of characteristics as listed in annex 7, table 1.

---

<sup>\*/</sup> The proposed scheme is designed to assess the compliance of filament lamps to an acceptance level of non-compliance of 1% and 6.5% respectively and is based on the Double Sampling Plan for Normal Inspection in IEC Publication 410: Sampling Plans and Procedure for Inspection by Attributes

UNITED  
NATIONS

E



**Economic and Social  
Council**

Distr.

GENERAL

TRANS/WP.29/622

2 June 1998

ENGLISH

Original:

ENGLISH  
and FRENCH

ECONOMIC COMMISSION FOR EUROPE  
INLAND TRANSPORT COMMITTEE  
**Working Party on the Construction of  
Vehicles**

DRAFT SUPPLEMENT 16 TO THE 03 SERIES OF AMENDMENTS TO REGULATION No. 37  
(Filament lamps)

**Note:** The text reproduced below was adopted by the Administrative Committee (AC.1) of the amended 1958 Agreement at its eighth session, following the recommendation by the Working Party at its one-hundred-and-fourteenth session. It is based on document TRANS/WP. 29/1998/19, as amended (TRANS/WP. 29/609, paras. 68 and 119).

List of contents, annexes, annex 1.

Add at the end of the list new sheets, to read:

".....  
Sheets H11"

Annex 1, sheet R2/1, replace in the table the IEC sheet number by "sheet 7004-95-5".

Annex 1, sheet P21/4W/1, replace in the table the IEC sheet number by "sheet 7004-11C-2".

Annex 1, sheet H7/2, replace in the table the IEC sheet number by "sheet 7004-5-3".

Annex 1, sheet H27W/2, replace in the table the IEC sheet number by "sheet 7004-107-2".

Annex 1, sheet H8/2, replace in the table the IEC cap designation by "PGJ 19-1".

Annex 1, sheet H4/1; replace in the table

" + 0.45	by	" + 0.35
- 0.25"		- 0.25"

Annex 1, replace the existing sheets H3/1 to H3/6 by new sheets H3/1 to H3/4 and add at the end new Sheets H11/1 to H11/4, to read:



**CATEGORY H3**

Sheet H3/1

The drawings are intended only to illustrate the essential dimensions of the filament lamp

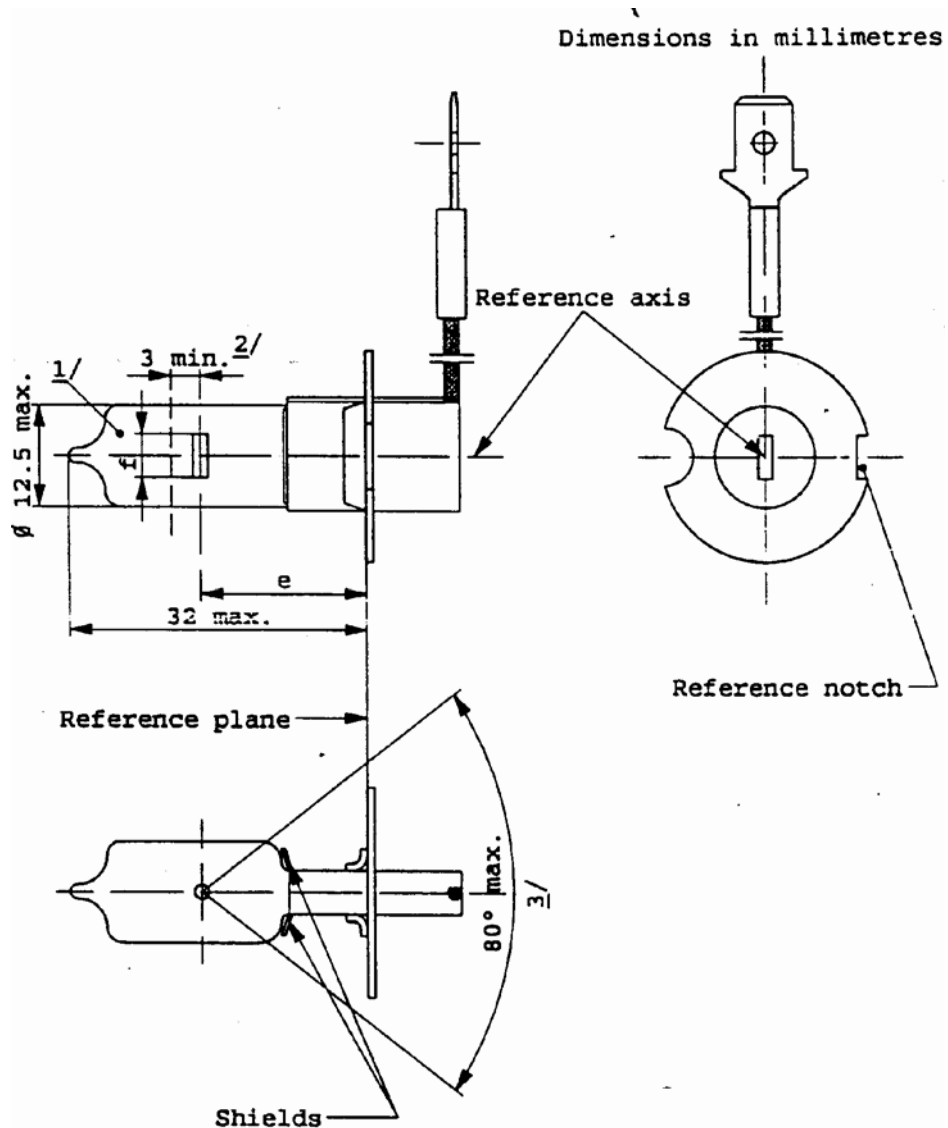

- 1/ Bulb colourless or selective-yellow.
- 2/ Minimum length above the height of the light emitting centre ("e") over which the bulb shall be cylindrical.
- 3/ The distortion of the base-end portion of the bulb shall not be visible from any direction outside the obscuration angle of 80 degrees max. The shields shall produce no inconvenient reflections. The angle between the reference axis and the plane of each shield, measured on the bulb side, shall not exceed 90.

**CATEGORY H3**

Sheet H3/2

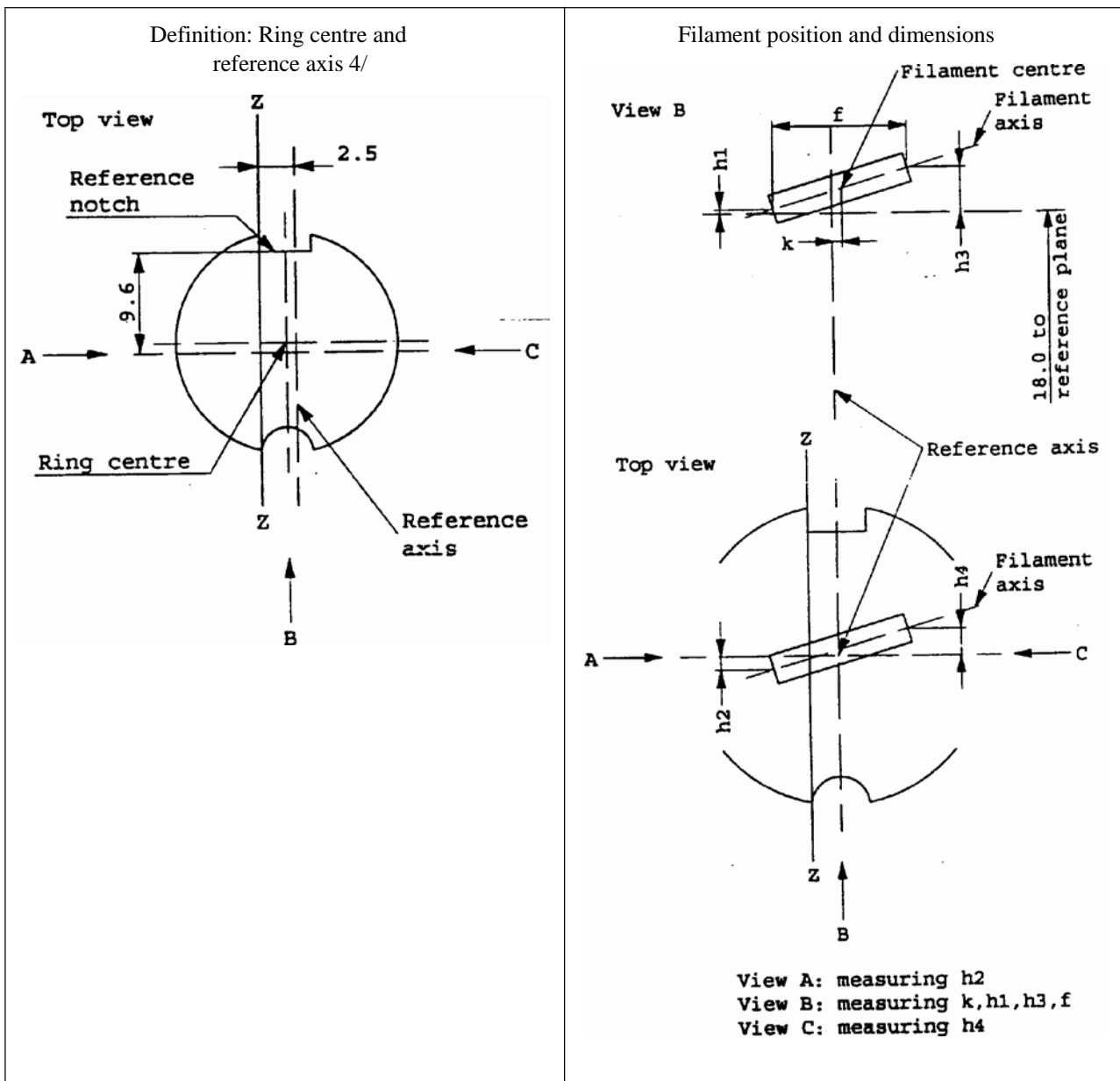

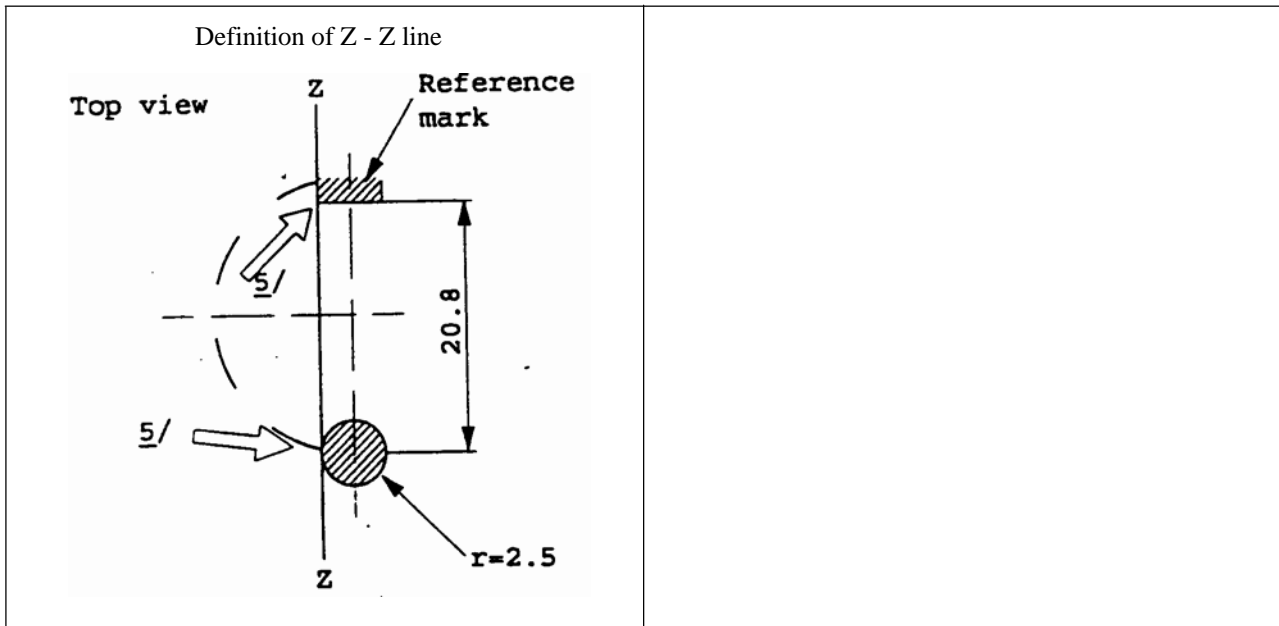

- 4/ The permissible deviation of the ring centre from the reference axis is 0.5 mm in the direction perpendicular to the Z-Z line and 0.05 mm in the direction parallel to the Z-Z line.
- 5/ The cap shall be pressed in these directions.

**CATEGORY H3**

**Sheet H3/3**

Dimensions in mm		Filament lamps of normal production			Standard filament lamp	
		6 V	12 V	24 V	12 V	
e		18.0 <sup>6/</sup>			18.0	
f <sup>8/</sup>		3.0 min.	4.0 min.		5.0 +/- 0.50	
k		0 <sup>6/</sup>			0 +/- 0.20	
h1, h3		0 <sup>6/</sup>			0 +/- 0.15 <sup>7/</sup>	
h2, h4		0 <sup>6/</sup>			0 +/- 0.25 <sup>7/</sup>	
Cap PK 22s in accordance with IEC Publication 61 (sheet 7004-47-4)						
ELECTRICAL AND PHOTOMETRIC CHARACTERISTICS						
Rated values		Volts	6	12	24	12
		Watts	55		70	55
Test voltage		Volts	6.3	13.2	28.0	13.2
Objective values		Watts	63 max.	68 max.	84 max.	68 max.
		Luminous flux 1m +/-%	1050	1450	1750	
			15			
Reference luminous flux: 1100 1m at approx. 12V						

- <sup>6/</sup> To be checked by means of a "box-system"; sheet H3/4.
- <sup>7/</sup> For standard filament lamps the points to be measured are those where the projection of the outside of the end turns crosses the filament axis.
- <sup>8/</sup> The positions of the first and the last turn of the filament are defined by the intersections of the outside of the first and of the last light emitting turn, respectively, with the plane parallel to and 18 mm distant from the reference plane (additional instructions for coiled-coil filament are under consideration).

**CATEGORY H3**

Sheet H3/4

Screen projection requirements

This test is used to determine, by checking whether the filament is correctly positioned relative to the reference axis and the reference plane, whether a filament lamp complies with the requirements.

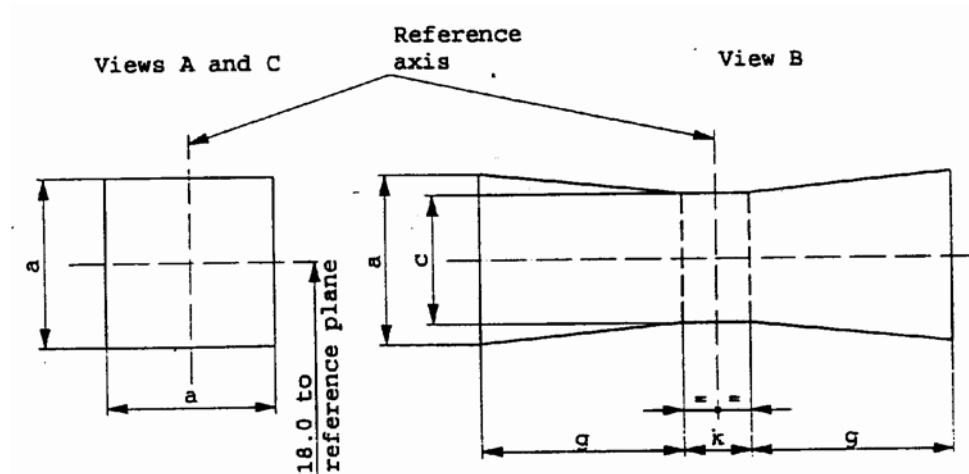

	a	c	k	g
6 V	1.8 d	1.6 d	1.0	2.0
12 V				2.8
24 V				2.9

d = diameter of filament

The filament shall lie entirely within the limits shown.

The centre of the filament shall lie within the limits of dimension k.

**CATEGORY H11**

Sheet H11/1

The drawings are intended only to illustrate the essential dimensions of the the filament lamp

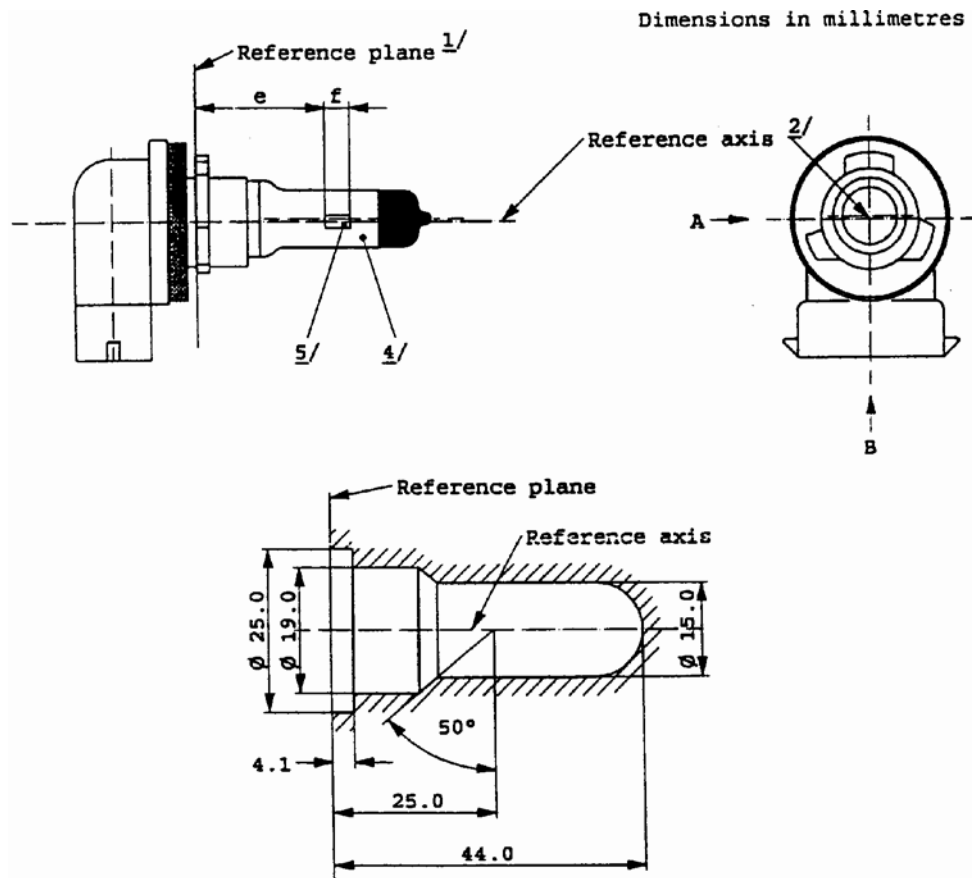

- 1/ The reference plane is the plane formed by the underside of the beveled lead-in flange of the cap.
- 2/ The reference axis is perpendicular to the reference plane and passing through the centre of the 19 mm cap diameter.
- 3/ Glass bulb and supports shall not exceed the envelope as indicated in figure 2. The envelope is concentric to the reference axis.
- 4/ The bulb shall be colourless or yellow.
- 5/ Notes concerning the filament diameter.
  - No actual diameter restrictions apply but the objective for future developments is to have - d max. = 1.4 mmFor the same manufacturer, the design diameter of standard (etalon) filament lamp and filament lamp of normal production shall be the same.

**CATEGORY H11**

Sheet H11/2

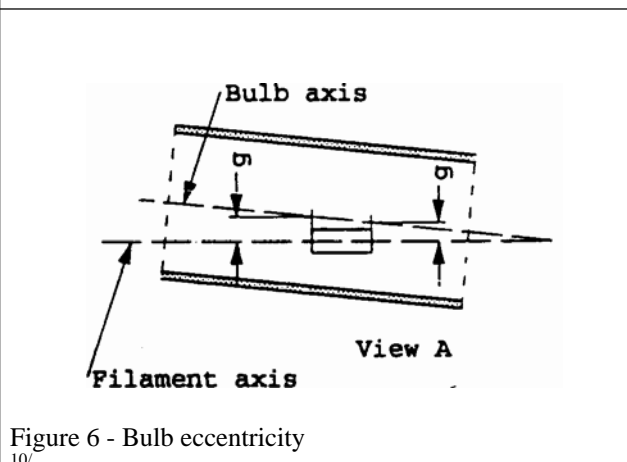
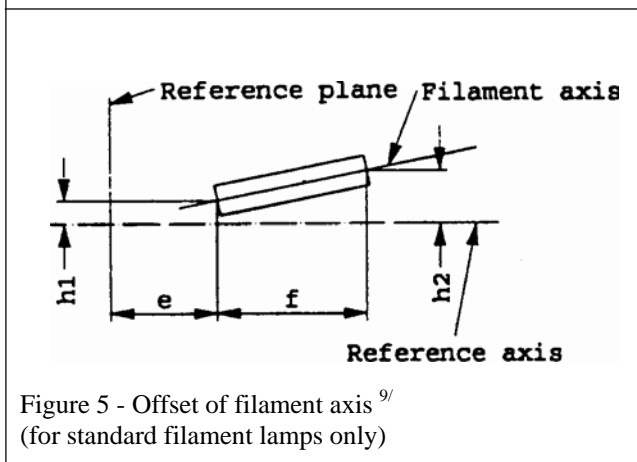
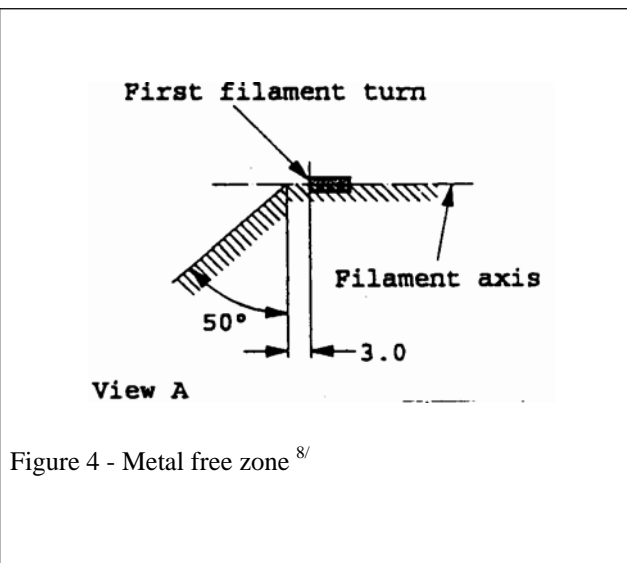
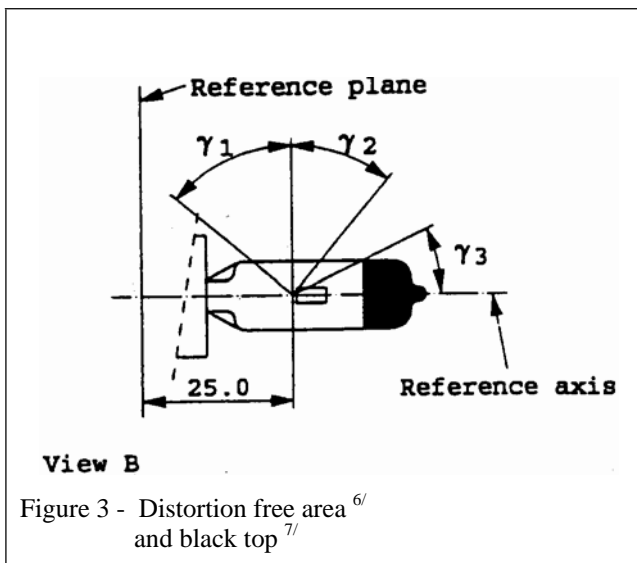

<sup>6/</sup> Glass bulb shall be optically distortion free within the angles  $g_1$  and  $g_2$ . This requirement applies to the whole bulb circumference within the angles  $g_1$  and  $g_2$ .

<sup>7/</sup> The obscuration shall extend at least to angle  $g_3$  and shall extend at least to the cylindrical part of the bulb on the whole bulb top circumference.

<sup>8/</sup> The internal design of the lamp shall be such that the stray light images and reflections are only located above the filament itself seen from the horizontal direction. (View A as indicated in figure 1, sheet H11/1).

No metal parts other than filament turns shall be located in the shaded area as seen in figure 4.

<sup>9/</sup> The offset of the filament with respect to the reference axis is measured only in viewing directions A and B as shown in figure 1 on sheet H11/1. The points to be measured are those where the projection of the outside of the end turns nearest to or furthest from the reference plane crosses the filament axis.

<sup>10/</sup> Eccentricity of bulb with respect to filament axis measured in two planes parallel to the reference plane where the projection of the outside of the end turns nearest to or furthest from the reference plane crosses the filament axis.

**CATEGORY H11**

Sheet H11/3

Dimensions in mm	Filament lamp of normal production		Standard filament lamp	
	12 V	24 V	12 V	
e <sup>11/</sup>	25.0		25.0 +/- 0.1	
f <sup>11/</sup>	4.5	5.3	4.5 +/- 0.1	
g	0.5 min.		u.c.	
h1	0 <sup>12/</sup>		0 +/- 0.1	
h2	0 <sup>12/</sup>		0 +/- 0.15	
gamma <sub>1</sub>	50 degrees min.		50 degrees min.	
gamma <sub>2</sub>	40 degrees min.		40 degrees min.	
gamma <sub>3</sub>	30 degrees min.		30 degrees min.	
Cap PGJ 19-2 in accordance with IEC Publication 61 (sheet 7004-110-1)				
<b>ELECTRICAL AND PHOTOMETRIC CHARACTERISTICS</b>				
Rated values	Volts	12	24	12
	Watts	55	70	55
Test voltage	Volts	13.2	28.0	13.2
Objective values	Watts	62 max.	80 max.	62 max.
	Luminous flux 1m +/- %	1350	1600	
		10	10	
Reference luminous flux for headlamp testing: 1000 1m at approx. 12V				

- 11/ The ends of the filament are defined as the points where, when the viewing direction is View A as shown in figure 1, sheet H11/1. the projection of the outside of the end turns crosses the filament axis.
- 12/ To be checked by means of a "Box system", sheet H11/4.



**CATEGORY H11**

Sheet H11/4

Screen projection requirements

This test is used to determine, by checking whether the filament is correctly positioned relative to the reference axis and the reference plane, whether a lamp complies with the requirements.

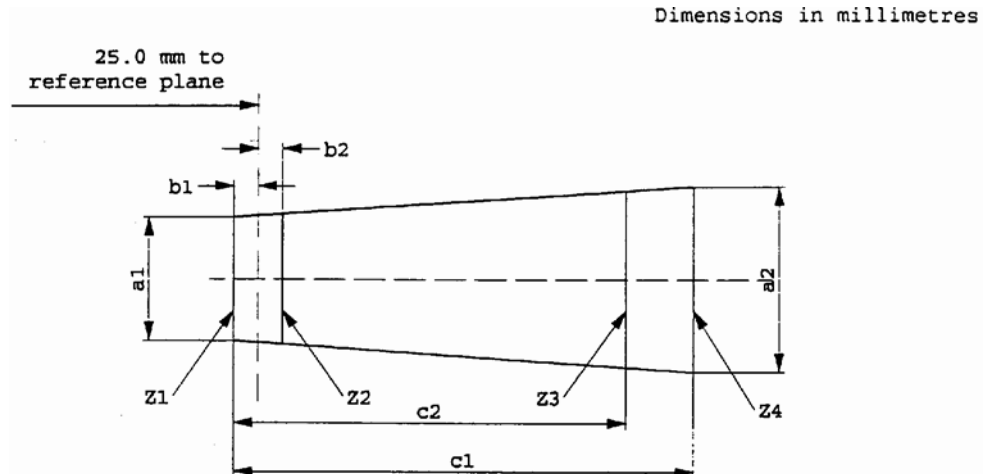

	a1	a2	b1	b2	c1	c2
12 V	$d + 0.3$	$d + 0.5$	0.2		5	4.0
24 V	$d + 0.6$	$d + 1.0$	0.25		6.3	4.6

$d$  = diameter of filament

The filament position is checked solely in directions A and B as shown on sheet H11/1.

The ends of the filament as defined on sheet H11/3, note <sup>11/</sup> shall lie between lines Z1 and Z2 and between lines Z3 and Z4.

The filament shall lie entirely within the limits shown.

UNITED  
NATIONS

E



**Economic and Social  
Council**

Distr.

GENERAL

TRANS/WP.29/649  
16 February 1999

ENGLISH

Original: ENGLISH  
and FRENCH

**ECONOMIC COMMISSION FOR  
EUROPE INLAND TRANSPORT  
COMMITTEE Working Party on the  
Construction of Vehicles**

DRAFT SUPPLEMENT 17 TO THE 03 SERIES OF AMENDMENTS TO REGULATION No. 37  
(Filament lamps)

**Note:** The text reproduced below was adopted by the Administrative Committee (AC. 1) of the amended 1958 Agreement at its tenth session, following the recommendation by the Working Party at its one-hundred- and-sixteenth session. It is based on document TRANS/WP.29/1998/51, as amended by the Working Party (TRANS/WP.29/640, para. 160).

Contents, Annex 1, amend to read (deleting also sheets S4 and inserting a new footnote\*/)

"Annex 1

Sheets R2  
Sheets H1  
Sheets H2  
Sheets H3  
Sheets H4  
Sheets P21W.....(only for signalling lamps) Sheets  
P21/4W ..... (only for signalling lamps)  
Sheets P21/5W ..... (only for signalling  
lamps) Sheets R5W.....(only for signalling  
lamps) Sheets R10W.....(only for signalling  
lamps) Sheets C5W.....(only for signalling  
lamps) Sheets C21W.....(only for signalling  
lamps) Sheets T4W.....(only for signalling  
lamps) Sheets W5W.....(only for signalling  
lamps) Sheets W3W.....(only for signalling  
lamps) Sheets S1 and S2  
Sheets S3  
Sheets HS1  
Sheets HS2  
Sheets PY21W.....(only for signalling lamps)  
Sheets H6W.....(only for signalling lamps)  
Sheets HB3  
Sheets HB4

Sheets T1.4W.....(only for signalling lamps)  
Sheets H7  
Sheets H27W/1 and H27W/2  
Sheets P27W.....(only for signalling lamps) Sheets  
P27/7W ..... (only for signalling lamps)  
Sheets WY5W.....(only for signalling lamps)  
Sheets H21W.....(only for signalling lamps)  
Sheets W21W.....(only for signalling lamps)  
Sheets W21/5W.....(only for signalling lamps)  
Sheets W2.3W.....(only for signalling lamps)  
Sheets H8  
Sheets W16W.....(only for signalling lamps) Sheets  
HIR1\*/  
Sheets PY27/7W.....(only for signalling lamps) Sheets  
HIR2  
Sheets H9\*/  
Sheets H10  
Sheets H11  
Sheets H12  
-----  
\*/

HIR1 and/or H9 filament lamps shall only be permitted to produce passing beam in conjunction with the installation of headlamp cleaning device(s) conforming to Regulation No. 45. In addition, with respect to vertical inclination, the provision of paragraph 6.2.6.2.2. of Regulation No. 48, 01 series of amendments, shall not be applied when these lamps are installed.

This restriction shall apply as long as there is no general agreement on the use of levelling devices and headlamp cleaners with respect to the level of the performance of the headlamp."

The text of the Regulation,

Annex 1,

Sheets S4, should be deleted.

Sheet PY21W/1 (existing), replace by the new sheet PY21W/1.

Add at the end new sheets H12/1 to H12/3, to read:

**CATEGORY PY21W**

Sheet PY21W/1

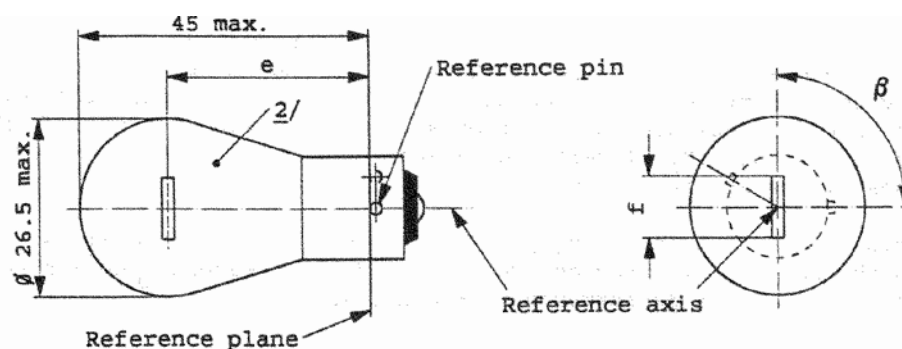

DIMENSIONS in mm	Filament lamps of normal production			Standard filament lamp		
	min.	nom.	max.			
e		31.8 <sup>3/</sup>		31.8 +/- 0.3		
f <sup>4/</sup>			7.0	7.0	+0	
					-2	
Lateral deviation <sup>1/</sup>		3/		0.3 max.		
beta	75 degrees	90 degrees	105 degrees	90 degrees +/- 5 degrees		
Cap BAU15s in accordance with IEC Publ. 61(sheet 7004-19-1)						
ELECTRICAL AND PHOTOMETRIC CHARACTERISTICS						
Rated values	V	12	24	12		
	W	21		21		
Test voltage	V	13.5	28.0			
Objective values	Watts	W	26.5 max.	29.7 max.	26.5 max. at 13.5V	
	Luminous flux	lm	280			
		+/- %	20			
Reference luminous flux:		Amber bulb : 280 lm		at approx. 13.5V		
		Clear bulb : 460 lm				

- 1/ Maximum lateral deviation of filament centre from two mutually perpendicular planes both containing the reference axis and one containing the reference axis and one containing the axis of the reference pin.
- 2/ The bulb of production lamps shall be amber. (See also note 5/).
- 3/ To be checked by means of a box system, sheet PY21W/2.
- 4/ For 24-Volt heavy-duty lamps having a different filament shape, additional specifications are under consideration.
- 5/ The bulb of standard filament lamps shall be amber or clear. For amber standard filament lamps, changes of the bulb temperature shall not affect the luminous flux which might impair photometric measurements of signalling devices. Moreover the colour shall be in the lower part of the tolerance area.

**CATEGORY PY21W**

Sheet PY21W/2

Screen projection requirements

This test is used to determine, by checking whether the filament is correctly positioned relative to the reference axis and the reference plane and has an axis perpendicular, within +/- 15 degrees, to the plane through the centre line of the reference pin and the reference axis, whether a filament lamp complies with the requirements.

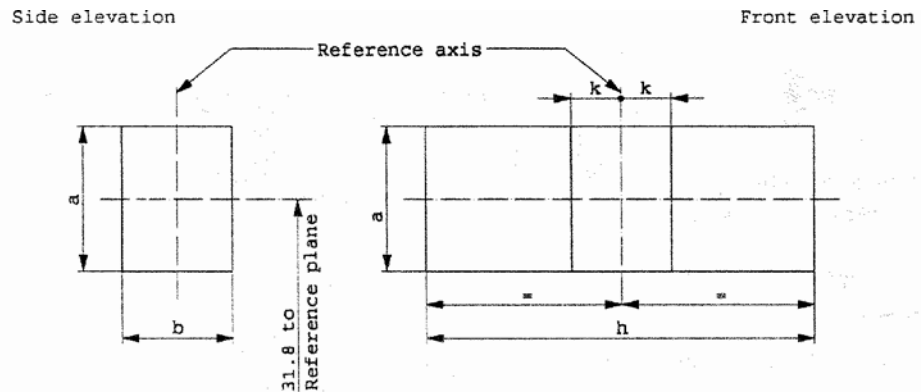

Reference	a	b	h	k
Dimension	3.5	3.0	9.0	1.0

Test procedures and requirements.

1. The filament lamp is placed in a holder capable of being rotated about its axis and having either a calibrated scale or fixed stops corresponding to the angular displacement tolerance limits. The holder is then so rotated that an end view of the filament is seen on the screen on to which the image of the filament is projected. The end view of the filament shall be obtained within the angular displacements tolerance limits.
2. **Side elevation**  
 The filament lamp placed with the cap down, the reference axis vertical and the filament seen end-on, the projection of the filament shall lie entirely within a rectangle of height "a" and width "b", having its centre at the theoretical position of the centre of the filament.
3. **Front elevation**  
 The filament lamp placed with the cap down and the reference axis vertical, the filament lamp being viewed in a direction at right angles to the filament axis:
  - 3.1 The projection of the filament shall lie entirely within a rectangle of height "a" and width "h", having its centre at the theoretical position of the centre of the filament.
  - 3.2 The centre of the filament shall not be offset by more than distance "k" from the reference axis.

**CATEGORY H12**

Sheet H12/1

The drawings are only to illustrate the essential dimensions of the filament lamp

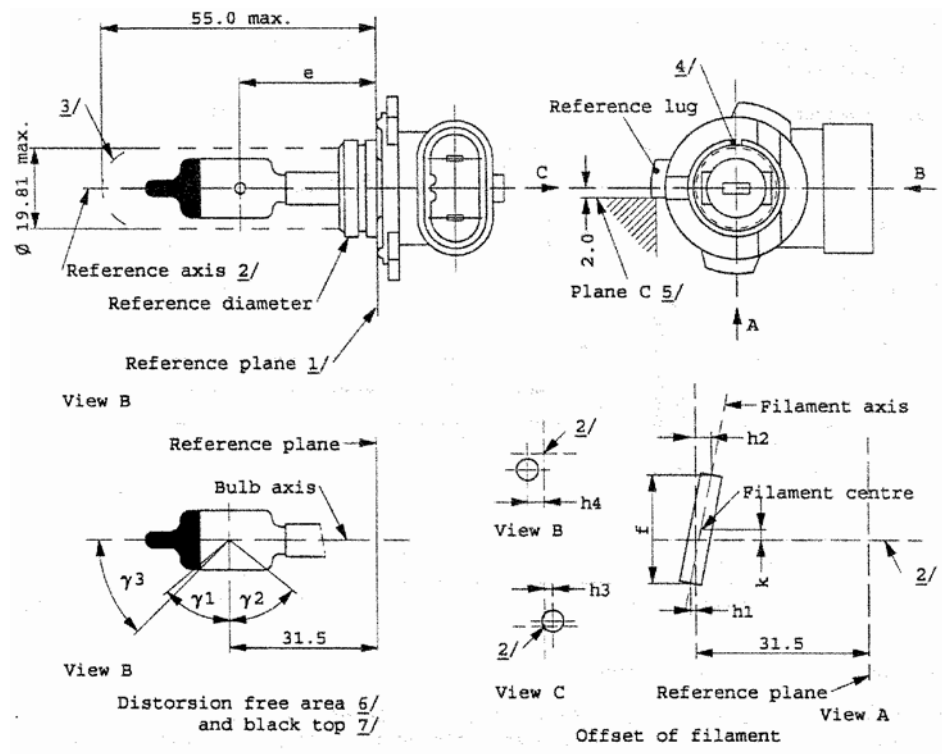

- 1/ The reference plane is the plane defined by the meeting points of the cap-holder fit.
- 2/ The reference axis is perpendicular to the reference plane and concentric with the reference diameter of the cap.
- 3/ Glass bulb and supports shall not exceed the envelope and shall not interfere with insertion past the lamp key. The envelope is concentric to the reference axis.
- 4/ The keyway is mandatory.
- 5/ The filament lamp shall be rotated in the measuring holder until the reference lug contacts plane C of the holder.
- 6/ Glass bulb periphery shall be optically distortion-free axially within the angles  $\gamma_1$  and  $\gamma_2$ . This requirement applies to the whole bulb circumference within the angles  $\gamma_1$  and  $\gamma_2$ .
- 7/ The obscuration shall extend to at least angle  $\gamma_3$  and shall be at least as far as the undistorted part of the bulb defined by angle  $\gamma_1$ .

**CATEGORY H12**

Sheet H12/2

Dimensions in mm <sup>8/</sup>		Tolerances	
		Filament lamps of normal production	Standard filament lamp
e <sup>9/</sup> <sup>10/</sup>	31.5	11	+/- 0.16
f <sup>9/</sup> <sup>10/</sup>	5.5	11	+/- 0.16
h1, h2, h3, h4	0	11	+/- 0.15 <sup>12/</sup>
k	0	11	+/- 0.15 <sup>13/</sup>
gamma <sub>1</sub>	50degrees min.		
gamma <sub>2</sub>	52degrees min.		
gamma <sub>3</sub>	45degrees	+/- 5 degrees	+/- 5 degrees
Cap PZ20d in accordance with IEC Publ. 61 (sheet 7004-31-2)			
ELECTRICAL AND PHOTOMETRIC CHARACTERISTICS			
Rated values	Volts	22	12
	Watts	53	53
Test voltage	Volts	13.2	13.2
Objective values	Watts	61 max.	61 max.
	Luminous flux 1m	1050	
	+/- %	15	
Reference luminous flux: 775 1m at approx. 12V			

- 8/ Dimensions shall be checked with O-ring removed.  
9/ The viewing direction is direction A as shown in the figure on sheet H12/1.  
10/ The ends of the filament are defined as the points where, when the viewing direction as defined in note <sup>9/</sup> above, the projection of the outside of the end turns crosses the filament axis.  
11/ To be checked by means of a " box-system". Sheet H12/3.  
12/ Dimensions h1 and h2 are measured in viewing direction A, dimension h3 in direction C and dimension h4 in direction B as shown in the figure on sheet H12/ 1. The points to be measured are those where the projection of the outside of the end turns crosses the filament axis.  
13/ Dimension k is measured only in viewing direction A.

**CATEGORY H12**

Sheet H12/3

Screen projection requirements

This test is used to determine, by checking whether the filament is correctly positioned relative to the reference axis and the reference plane, whether a filament lamp complies with the requirements.

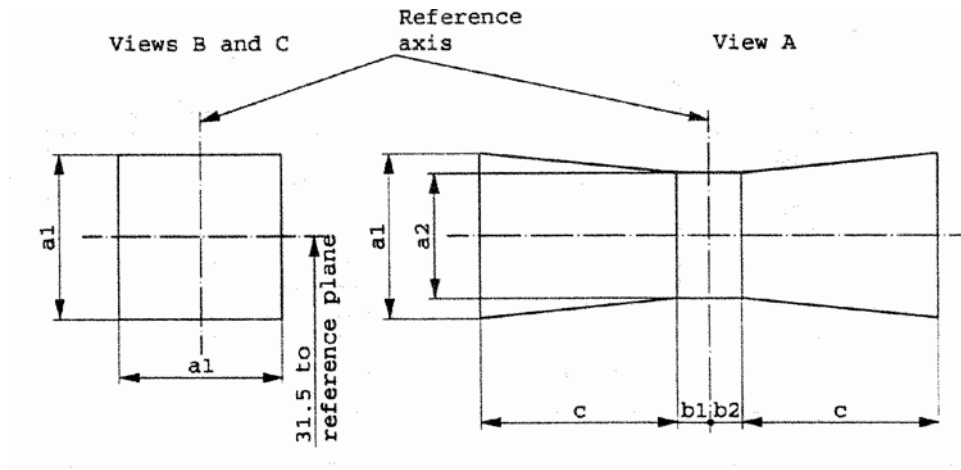

a1	a2	b1	b2	c
1.6 d	1.3 d	0.30	0.30	2.8

d = diameter of filament

For the directions of view A, B and C see sheet H12/1

The filament shall entirely lie within the limits shown.

The center of the filament shall lie between the limits of dimensions b1 and b2.



UNITED  
NATIONS

E



**Economic and Social  
Council**

Distr.

GENERAL

TRANS/WP.29/670  
16 April 1999

ENGLISH

Original: ENGLISH  
and FRENCH

**ECONOMIC COMMISSION FOR  
EUROPE INLAND TRANSPORT  
COMMITTEE Working Party on the  
Construction of Vehicles**

**DRAFT SUPPLEMENT 18 TO THE 03 SERIES OF AMENDMENTS TO REGULATION No. 37  
(Filament lamps)**

**Note:** The text reproduced below was adopted by the Administrative Committee (AC.1) of the amended 1958 Agreement at its eleventh session, following the recommendation by the Working Party at its one-hundred- and-seventeenth session. It is based on document TRANS/WP.29/ 1999/10, not amended (TRANS/WP.29/ 663, para. 119).

**List of contents annexes.**

**Annex 1.** delete "Sheets H2" and add at the end of the list "Sheets WY21W".

**Annex 1.** remove Sheets H2 and add at the end new Sheets WY21W/1 to WY21W/2 to read:

**CATEGORY WY21W**

Sheet WY21W/1

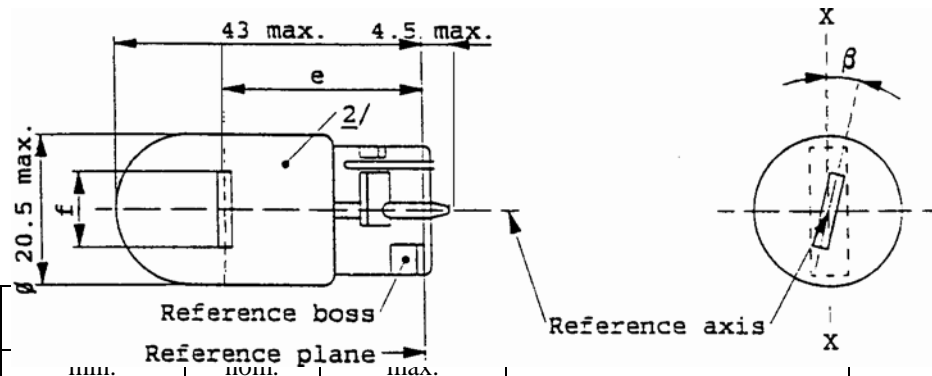

DIMENSIONS in min				
e		29.0		29.0+/-0.3
f			7.5	7.5 +0 -2
Lateral deviation			3/	0.3 max.
beta		-15 degrees 3/	0 degrees	+ 15 degrees 3/
0 degrees +/- 5 degrees				
Cap WX 3x16d in accordance with IEC Publ. 61 (sheet 7004-105-2)				
<b>ELECTRICAL AND PHOTOMETRIC CHARACTERISTICS</b>				
Rated values	v	12		12
	W	21		21
Test voltage	v	13.5		
	Watts	W	26.5 max.	26.5 max. at 13.5V
Objective values	Luminous flux	lm	280	
		+/- %	20	
Reference luminous flux:		Amber bulb : 280 lm Clear bulb : 460 lm		at approx. 13.5V

- <sup>1/</sup> Maximum lateral deviation of filament centre from two mutually perpendicular planes both containing the reference axis and one containing the axis X-X.
- <sup>2/</sup> The bulb of production lamps shall be amber. (See also note 4/)
- <sup>3/</sup> To be checked by means of a box system, sheet WY21W/2.
- <sup>4/</sup> The bulb of standard filament lamps shall be amber or clear. For amber standard filament lamps, changes of the bulb temperature shall not affect the luminous flux which might impair photometric measurements of signalling devices. Moreover the colour shall be in the lower part of the tolerance area.

**CATEGORY WY21W**

Sheet WY21W/2

Screen projection requirements

This test is used to determine, by checking whether the filament is correctly positioned relative to the reference axis and the reference plane and has an axis perpendicular, within +/-15 degrees, to the plane through the axis X-X and the reference axis, whether a filament lamp complies with the requirements.

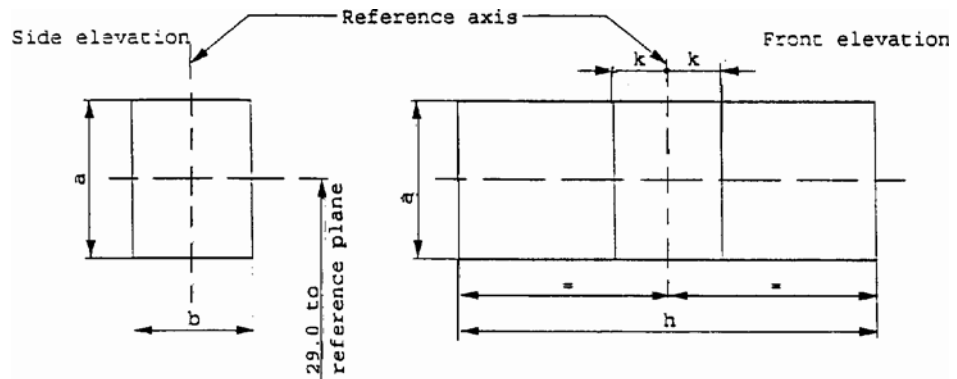

Reference	a	b	h	k
Dimension	3.5	3.0	9.5	1.0

Test procedure and requirements.

1. The filament lamp is placed in a holder capable of being rotated about its axis and having either a calibrated scale or fixed stops corresponding to the angular displacement tolerance limits, . i.e. +/-15 degrees . The holder is then so rotated that an end view of the filament is seen on the screen on to which the image of the filament is projected. The end view of the filament shall be obtained within the angular displacements tolerance limits. (+/-15 degrees )

**2. Side elevation**

The filament lamp placed with the cap down, the reference axis vertical and the filament seen end-on, the projection of the filament shall lie entirely within a rectangle of height "a" and width "b", having its centre at the theoretical position of the centre of the filament.

**3. Front elevation**

The filament lamp placed with the cap down and the reference axis vertical, the filament lamp being viewed in a direction at right angles to the filament axis:

- 3.1. The projection of the filament shall lie entirely within a rectangle of height "a" and width "h", having its centre at the theoretical position of the centre of the filament;
- 3.2. The centre of the filament shall not be offset by more than distance "k" from the reference axis.